

ATTACHMENT J-1
UNITeS STATEMENT OF WORK (SOW)
For Physical Models Of Launch Vehicles For NASA

16 November 2005
Version 1.0

UNITeS Statement of Work (SOW)

For Physical Models of Launch Vehicles for NASA

BACKGROUND:

The National Aeronautics and Space Administration (NASA) Marshall Space Flight Center (MSFC) has tasked Science Applications International Corporation (SAIC); the Prime, and it's Acquisition Services Subcontractor; Arcata Associates Inc. (Arcata/UNITeS), performing under the Unified NASA Information Technology Services (UNITeS) Prime Contract NNM04AA02C, to support their requirement for physical models of proposed launch vehicles, a total of five different formats/groupings. Requirements for the models, and associated equipment, are listed in this Statement of Work (SOW). UNITeS will select a single vendor to fulfill the requirements listed in this SOW.

SCOPE AND OBJECTIVES:

To design and build scale models from the following drawings. The information contained herein describes the overall model and detail and expectations for the final product. The bidding contractor is to interpret these drawings and devise a plan to manufacture the models as described. These drawings are not intended to solve manufacturing issues or propose a plan for manufacture. It is the bidding contractor's responsibility to develop and submit the plan for manufacturing the models.

The award contractor will work with UNITeS staff to review requirements and build required CAD models as required for construction. UNITeS will provide detailed dimensional drawings and consultation. The award contractor shall be required to provide review printed documents. All CAD files and other plates, molds, or other materials and data necessary for construction will become the property of the Government. The award contractor shall provide all CAD files to the UNITeS in STL or IGES format for review purposes.

The computer models used to develop these drawings are also available for review. These drawings are to aid in the understanding of the model geometry. These models are not suitable for manufacture. The information contained in this document supersedes any discrepancy between the computer files and this document.

Model Set A “LOFI-MODS”

1:144 Scale Low Fidelity Launch Vehicle Model Set

Overview of Contents.

Each Model Set A is to include an Acrylic base, Removable Cargo Launch Vehicle, removable Crew Launch Vehicle, and a padded corrugated box.

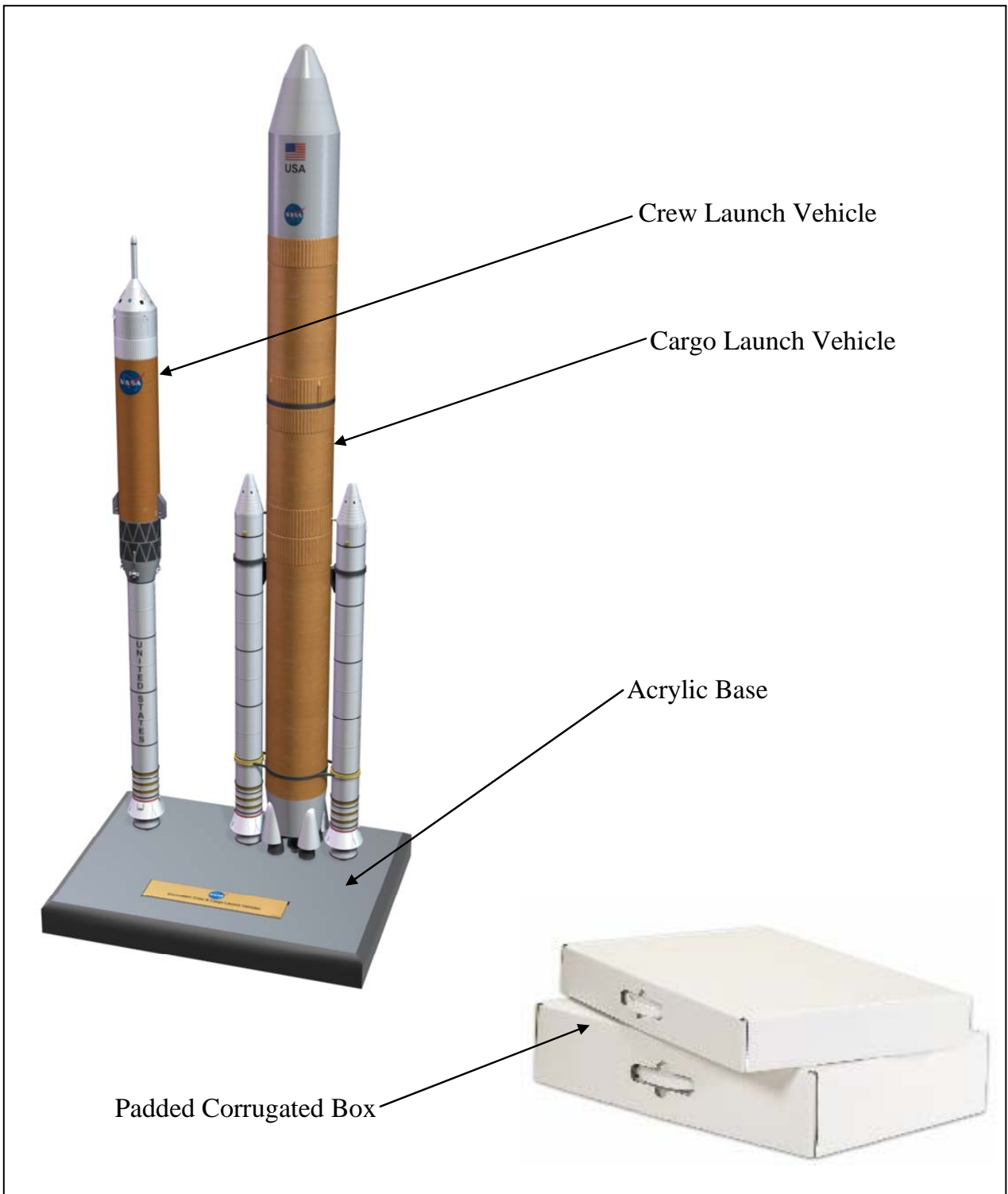

Model Set A – Figure A.1

1:144 Scale

Cargo Launch Vehicle Overall Dimensions

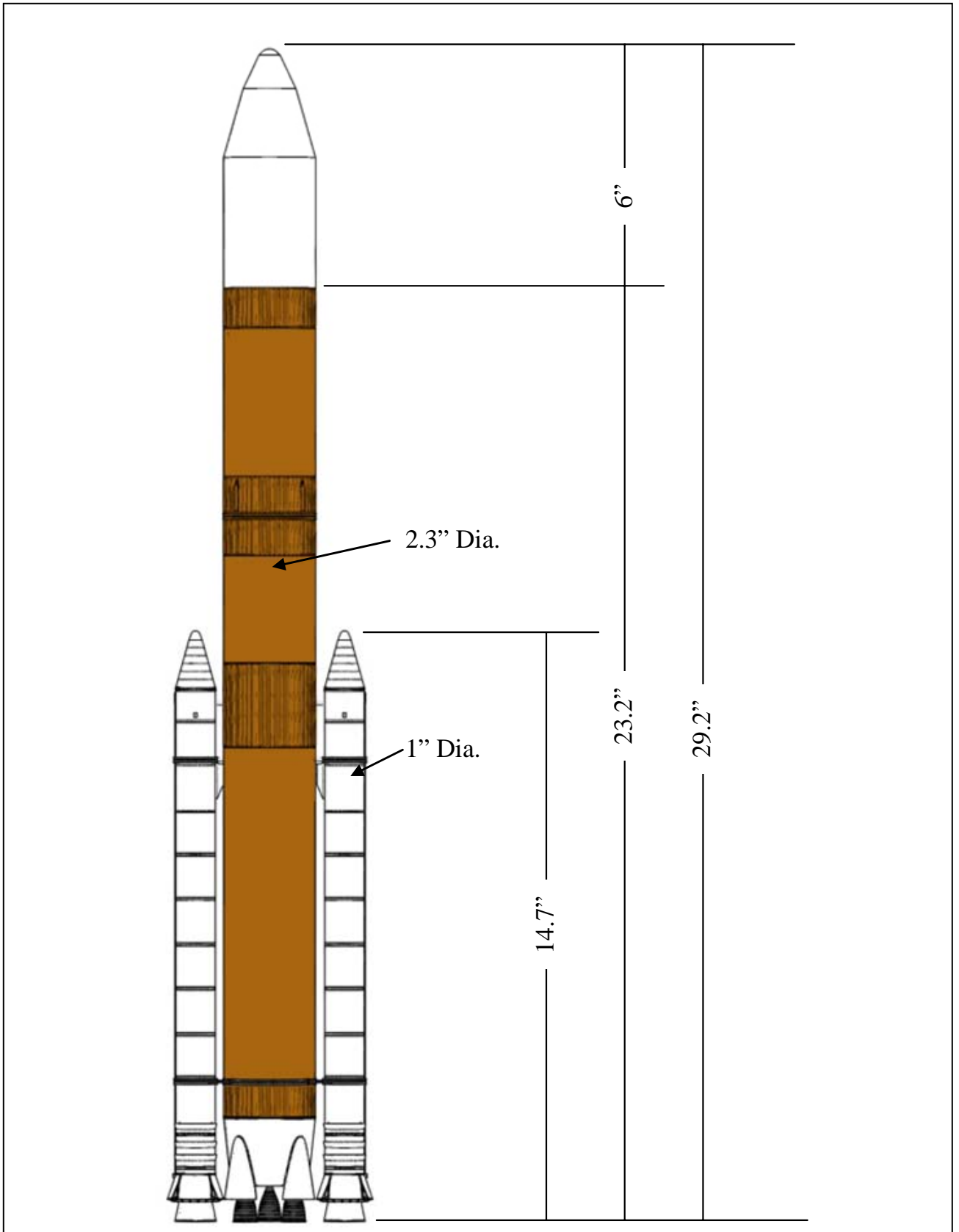

Model Set A – Figure A.2
Cargo Launch Vehicle General Details

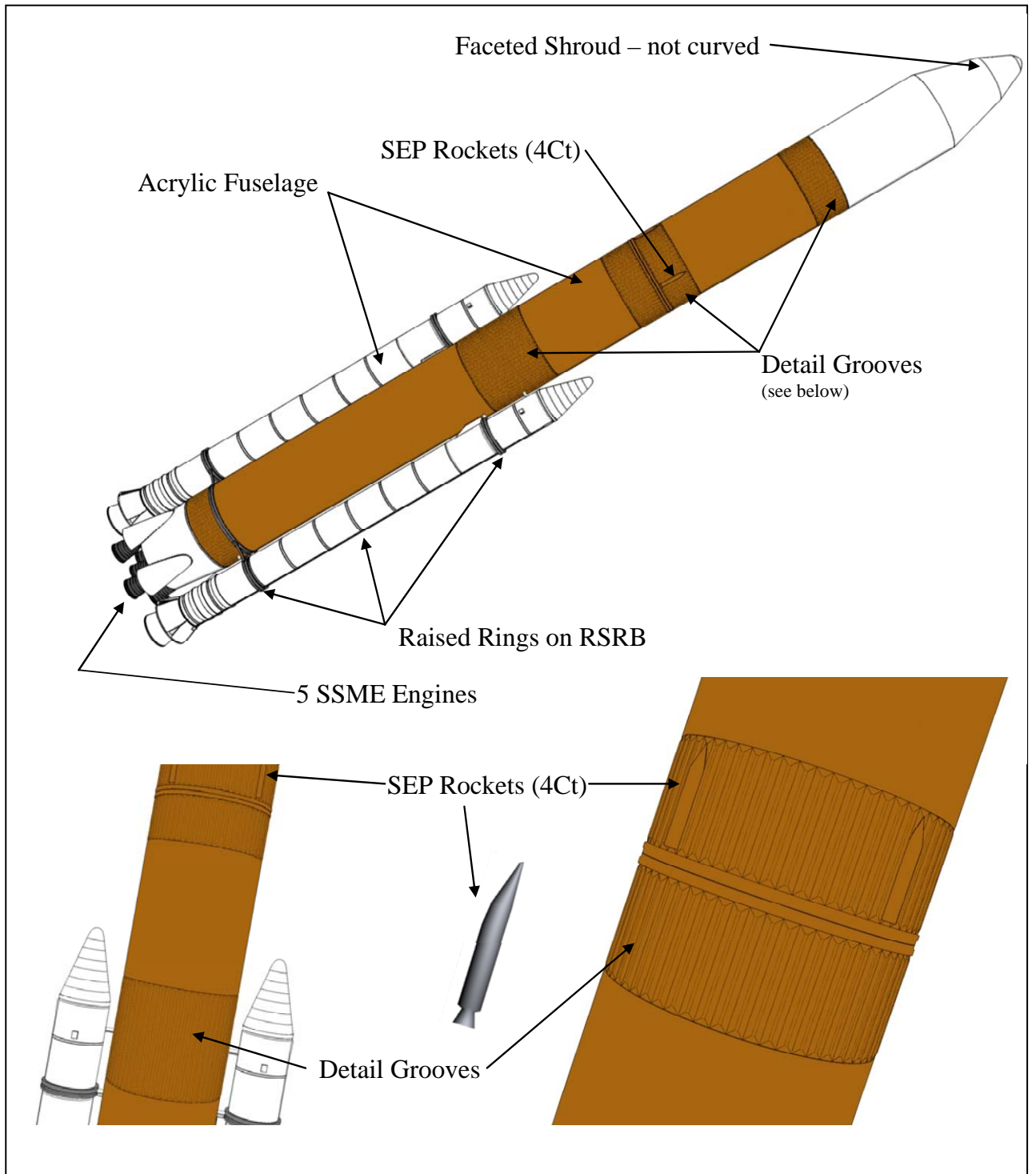

Model Set A – Figure A.3
Cargo Launch Vehicle Engine Area Detail

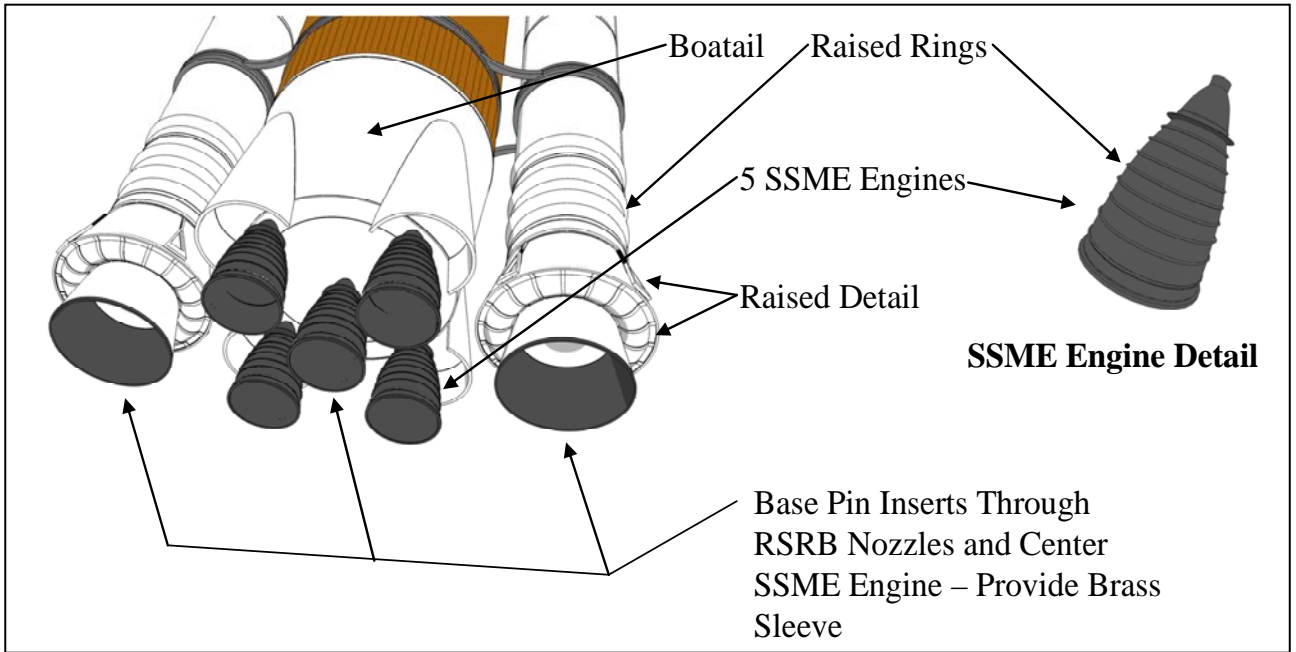

Model Set A – Figure A.4
 Cargo Launch Vehicle Colors, Finish and Details

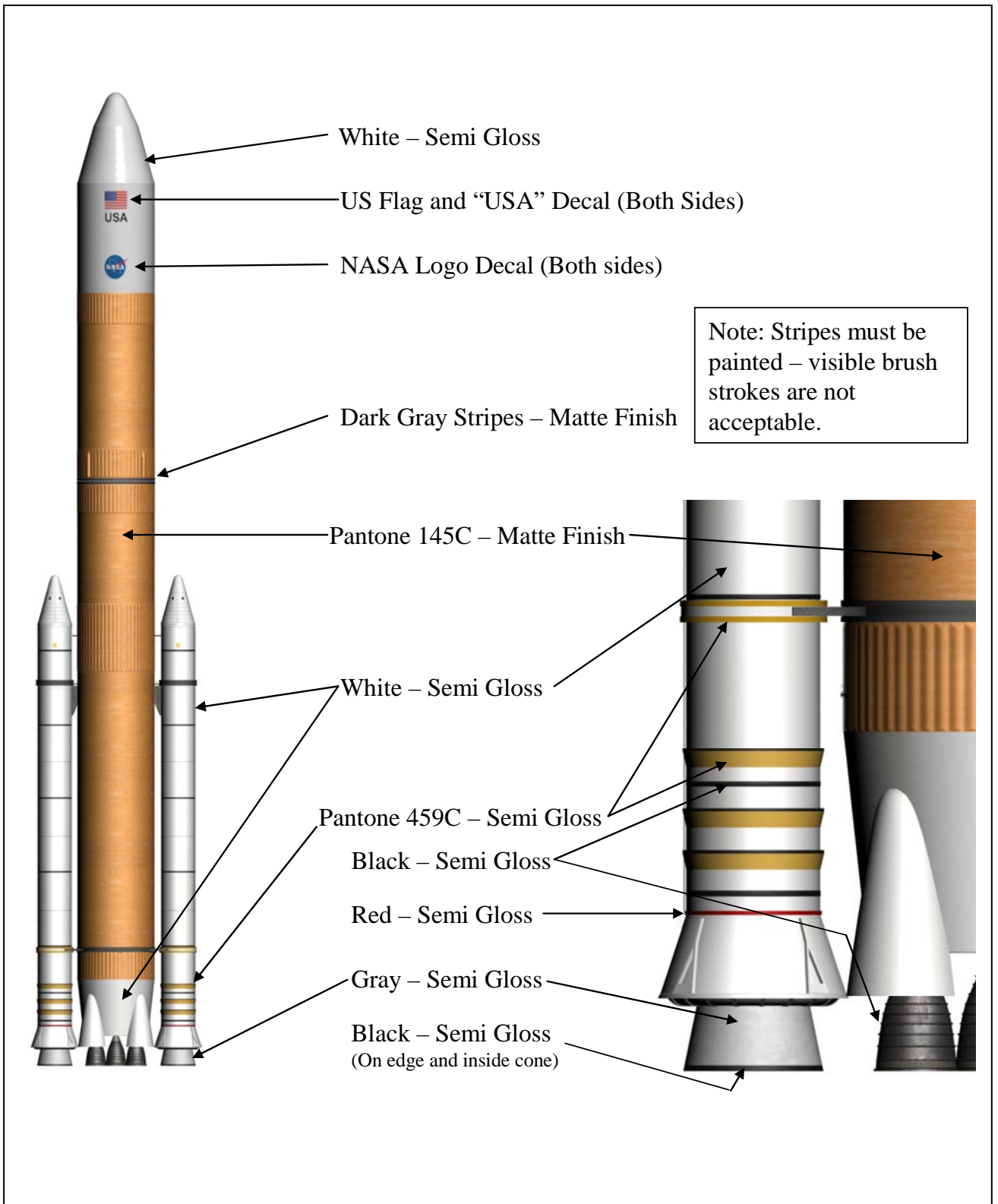

Model Set A – Figure A.5

1:144 Scale

Crew Launch Vehicle Overall Dimensions

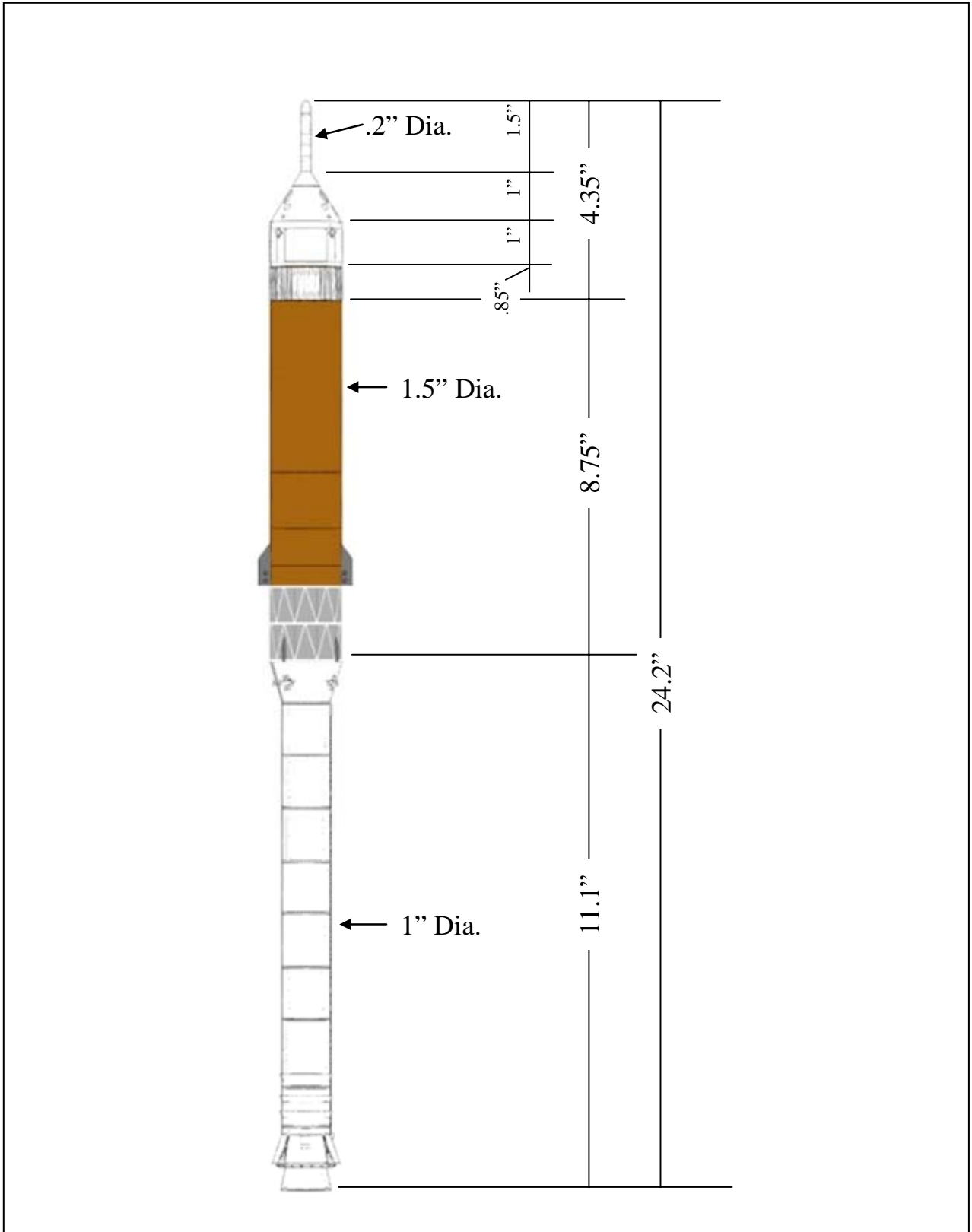

Model Set A – Figure A.6
 Crew Launch Vehicle General Details

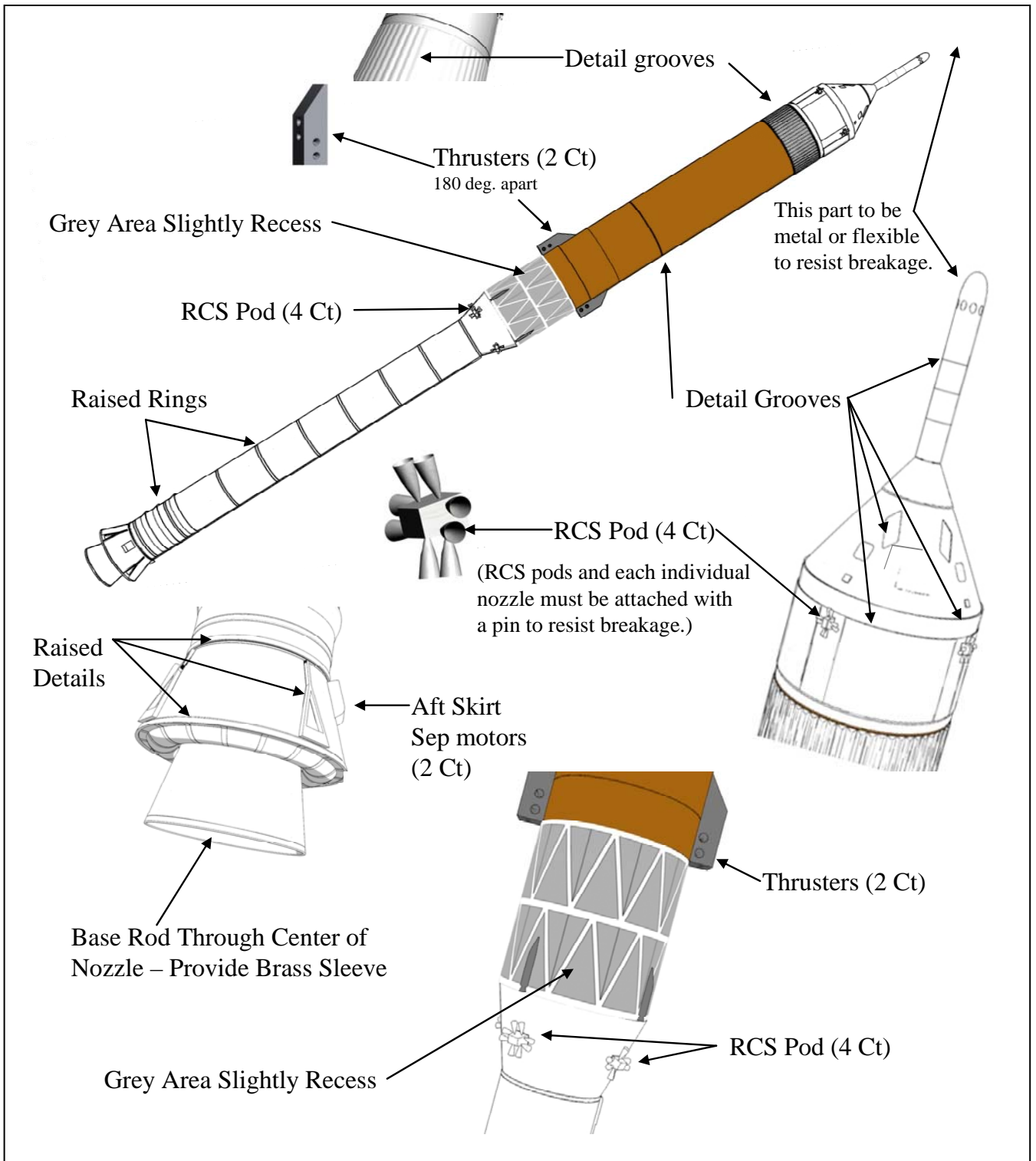

Model Set A – Figure A.7
 Crew Launch Vehicle Colors, Finish and Details

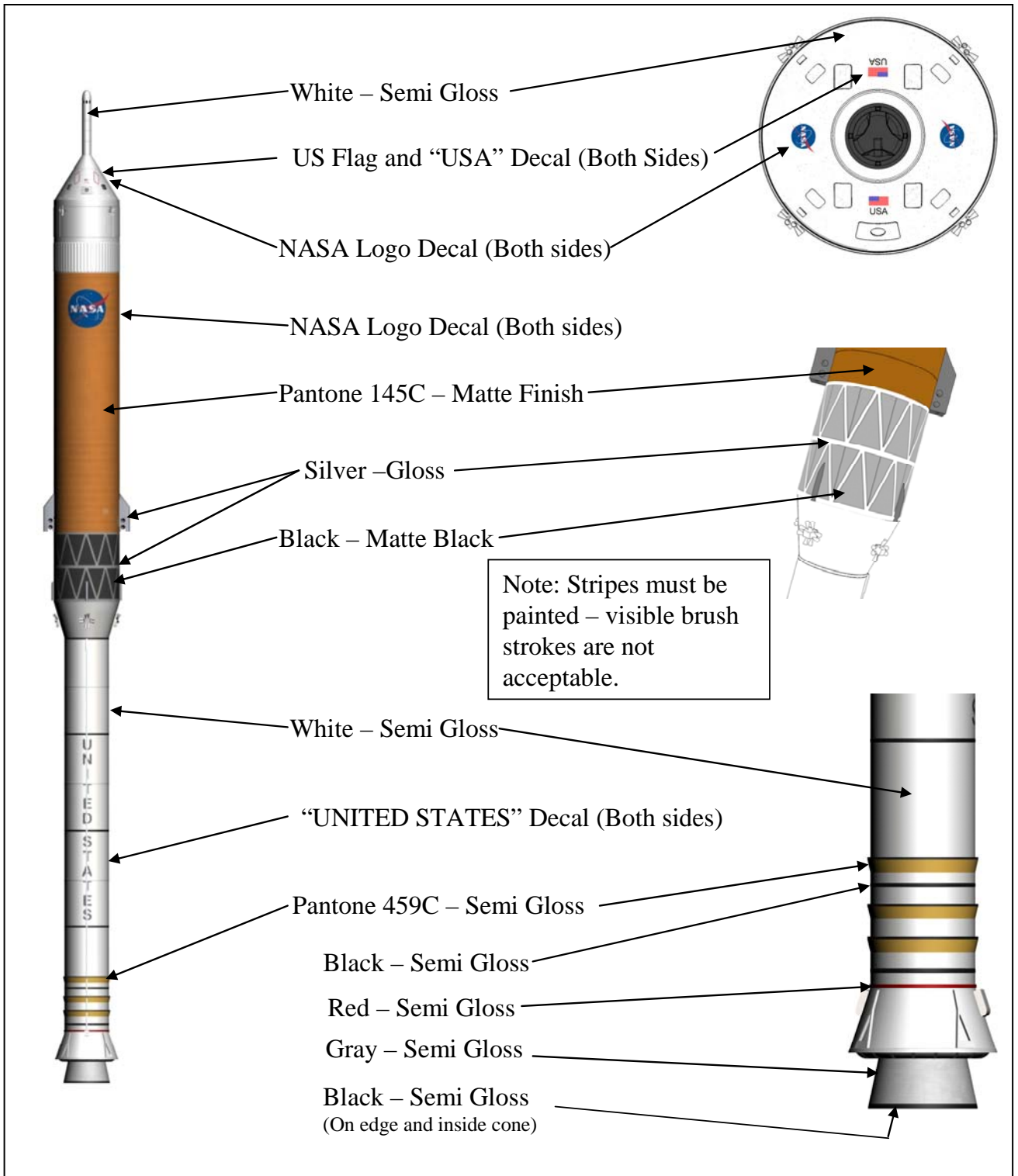

Model Set A – Figure A.8
Base Details

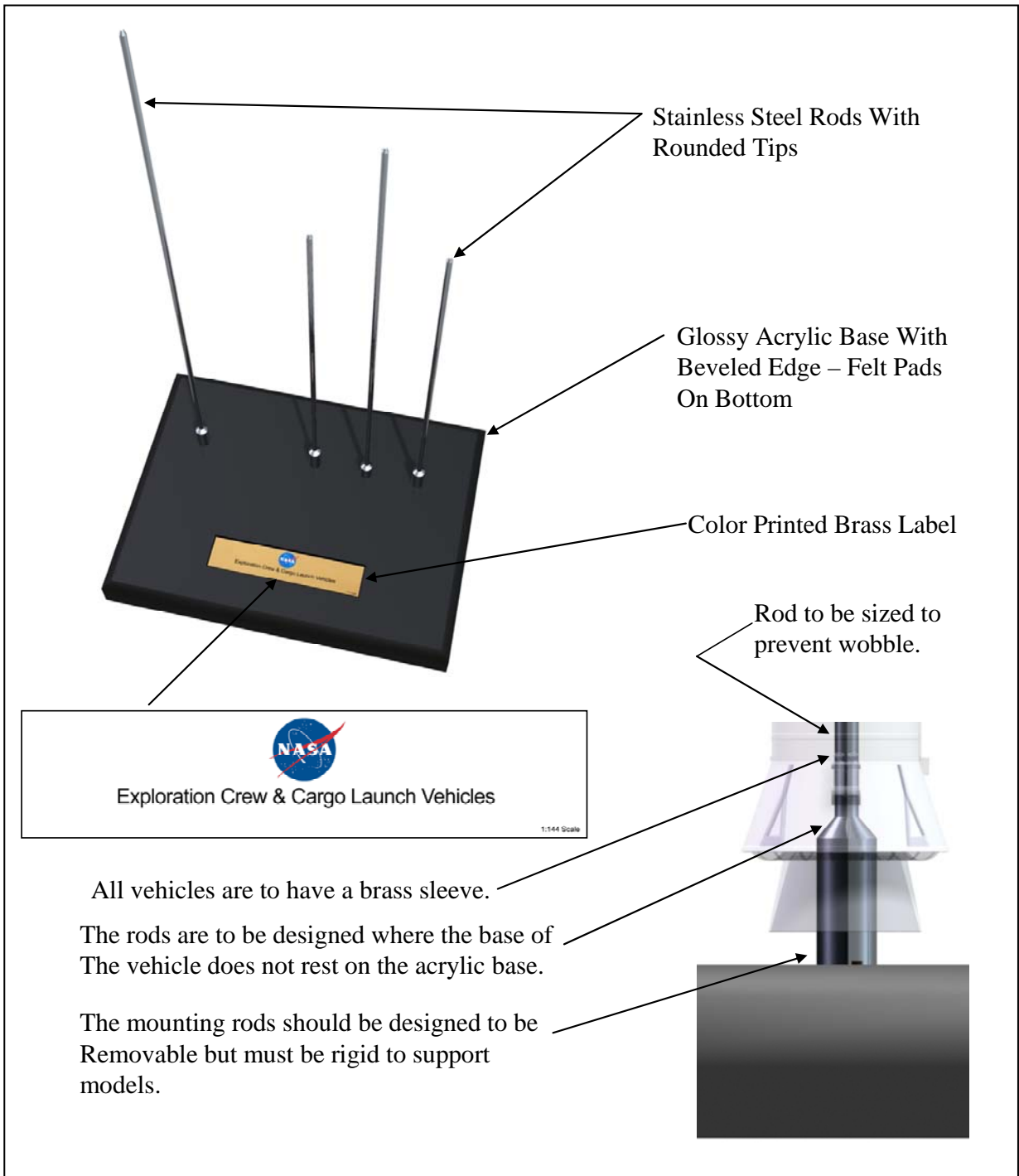

Model Set A – Figure A.9
Box Details

Case Details:

Each model is to have a rugged plastic case suitable for airline travel as shown below. The interior of the case should have custom molded foam padding. Each is to have a laminated label on the exterior similar to that shown in Figure A.8. Case of impact resistant plastic by Pelican or Equal.



Model Set B “HIFI-MODS”.

1:144 Scale High Fidelity Launch Vehicle Model Set

Overview of Contents.

Each Model Set B is to include an Acrylic base, Removable Cargo Launch Vehicle, removable Crew Launch Vehicle and padded rigid airline case.

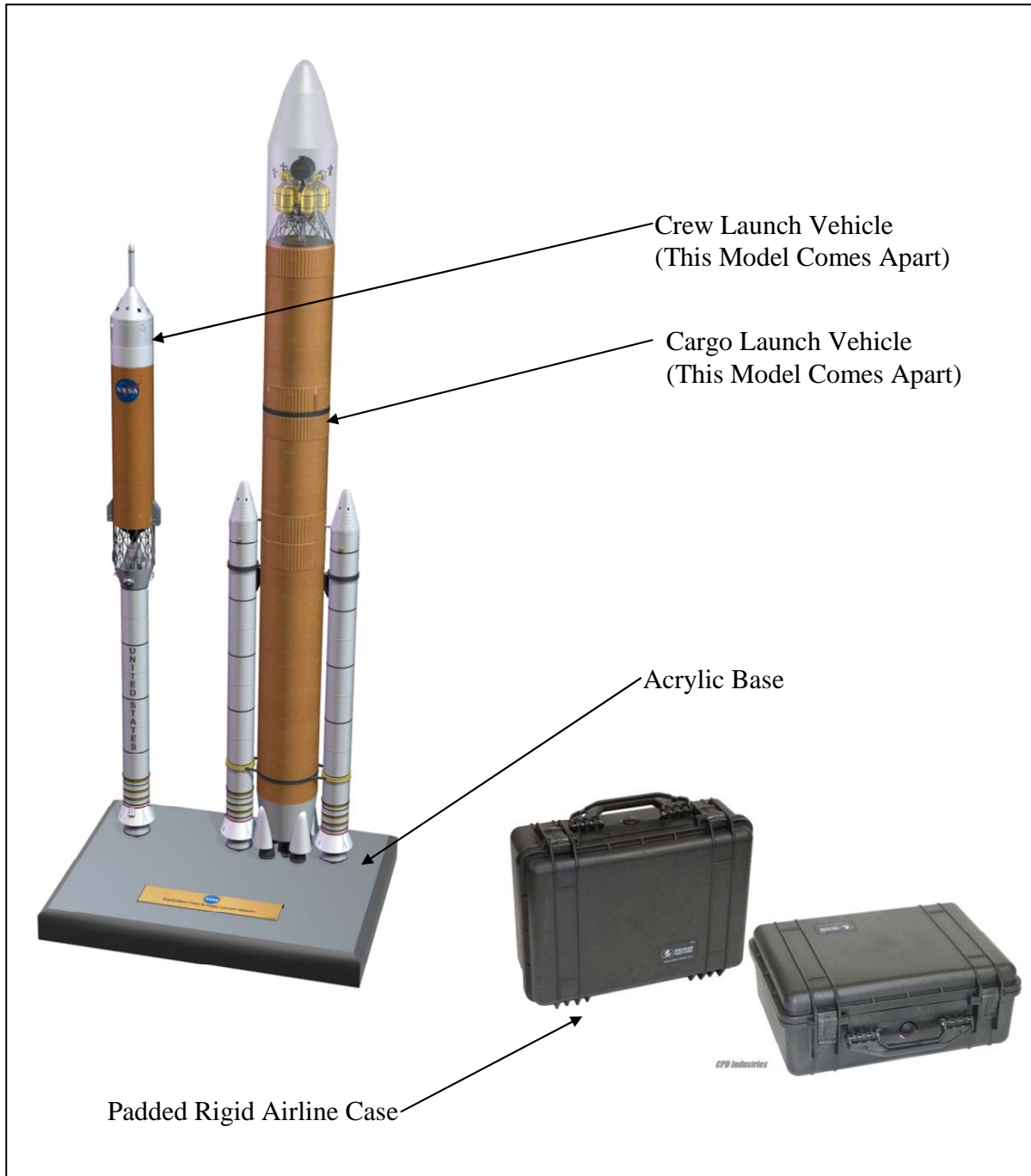

Model Set B – Figure B.1

1:144 Scale

Cargo Launch Vehicle Overall Dimensions

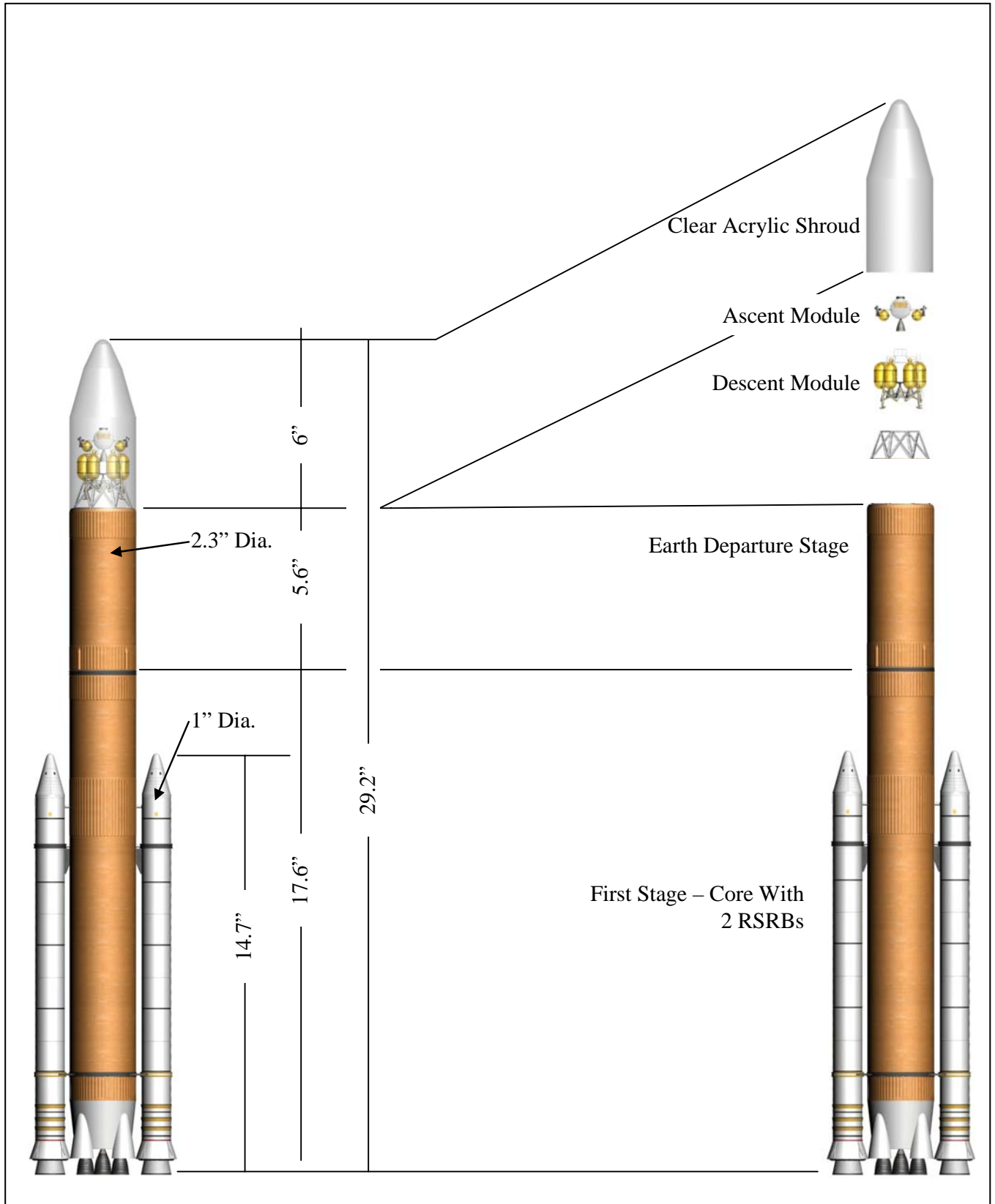

Model Set B – Figure B.2
Cargo Launch Vehicle Shroud Details

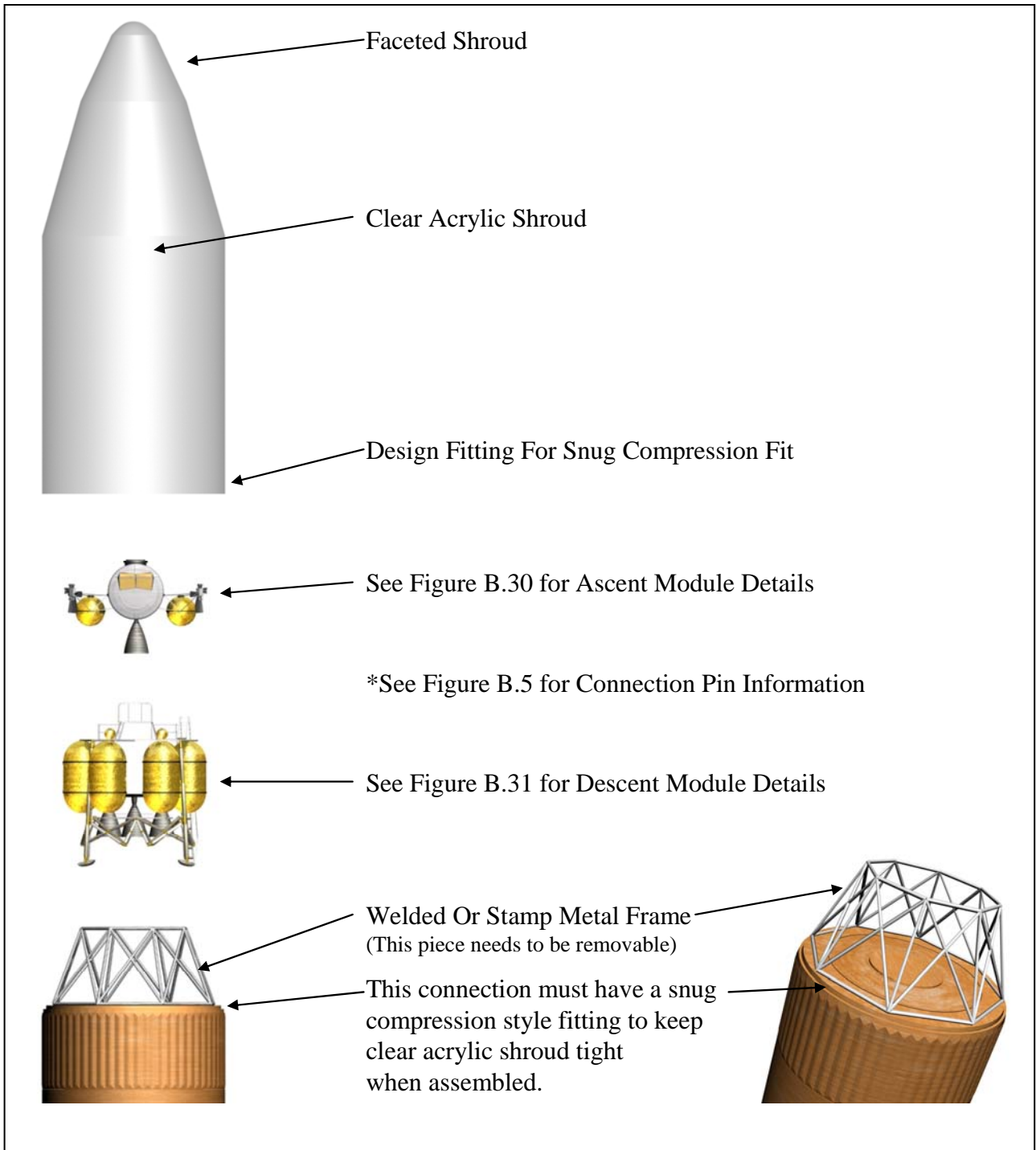

Model Set B – Figure B.3.0
1:144 Scale
Cargo Launch Vehicle Ascent Module

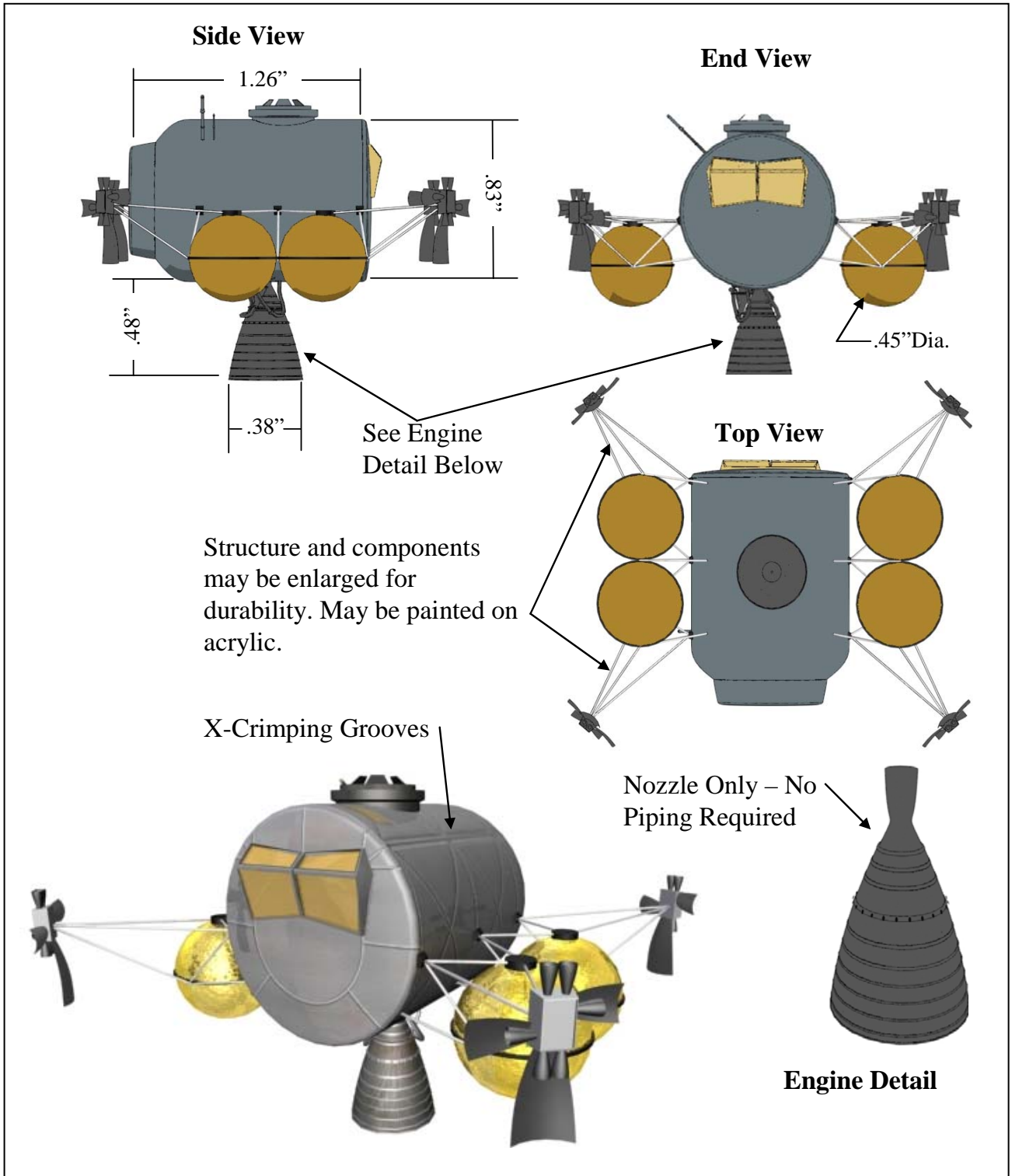

Model Set B – Figure B.3.1
Cargo Launch Vehicle Descent Module

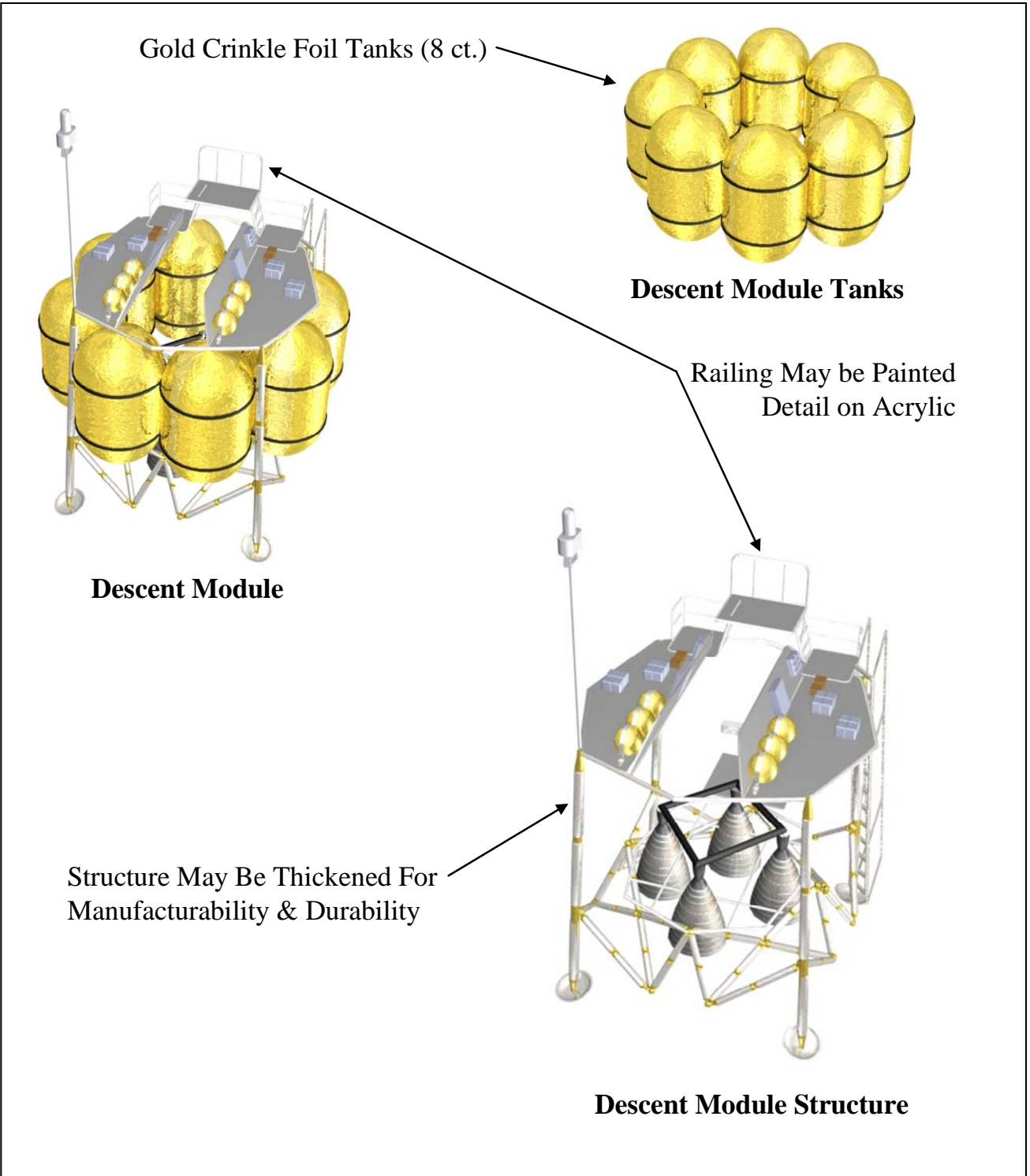

Model Set B – Figure B.4
Cargo Launch Vehicle Engine Details

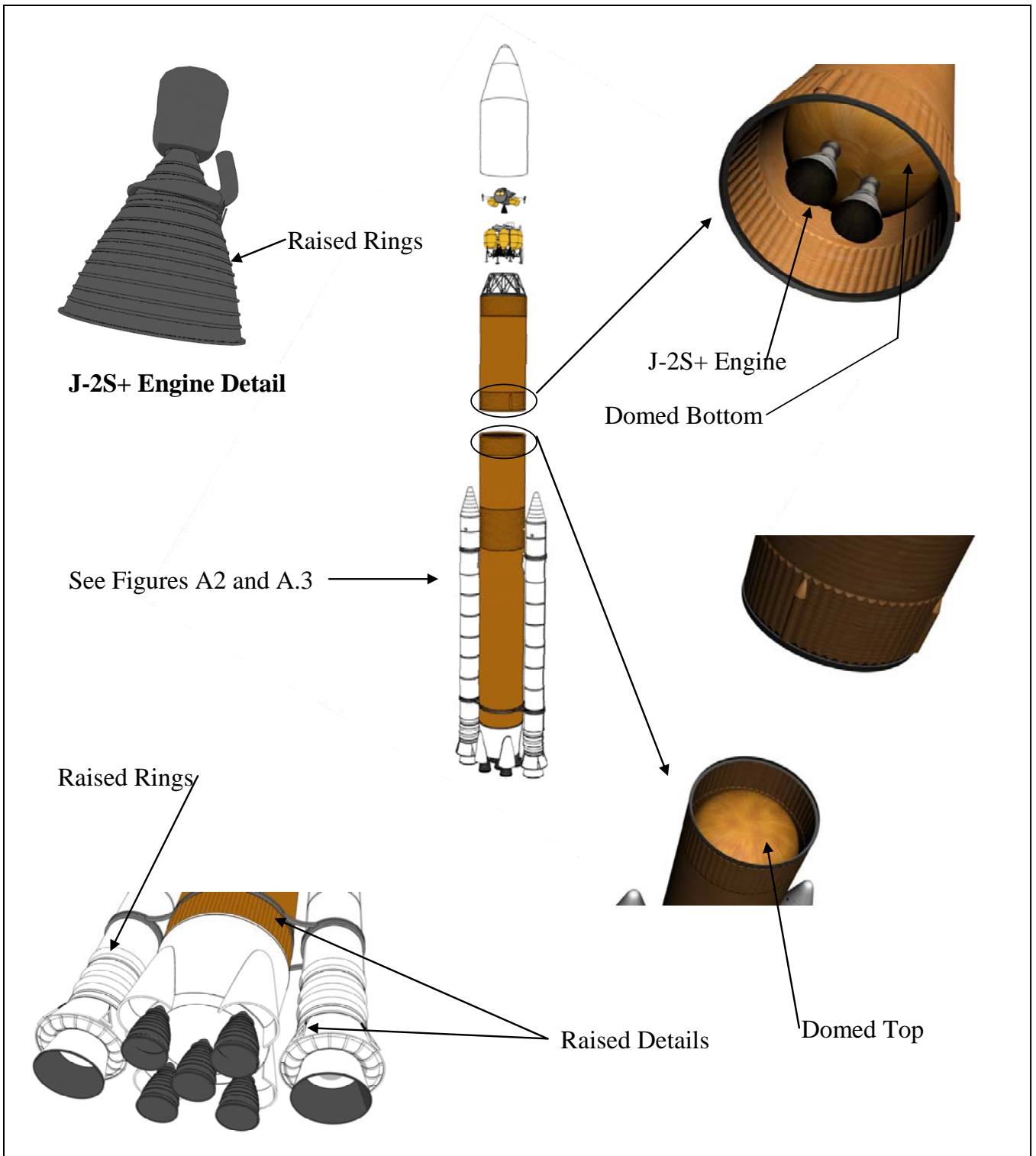

Model Set B – Figure B.5
Cargo Launch Vehicle Pin Details

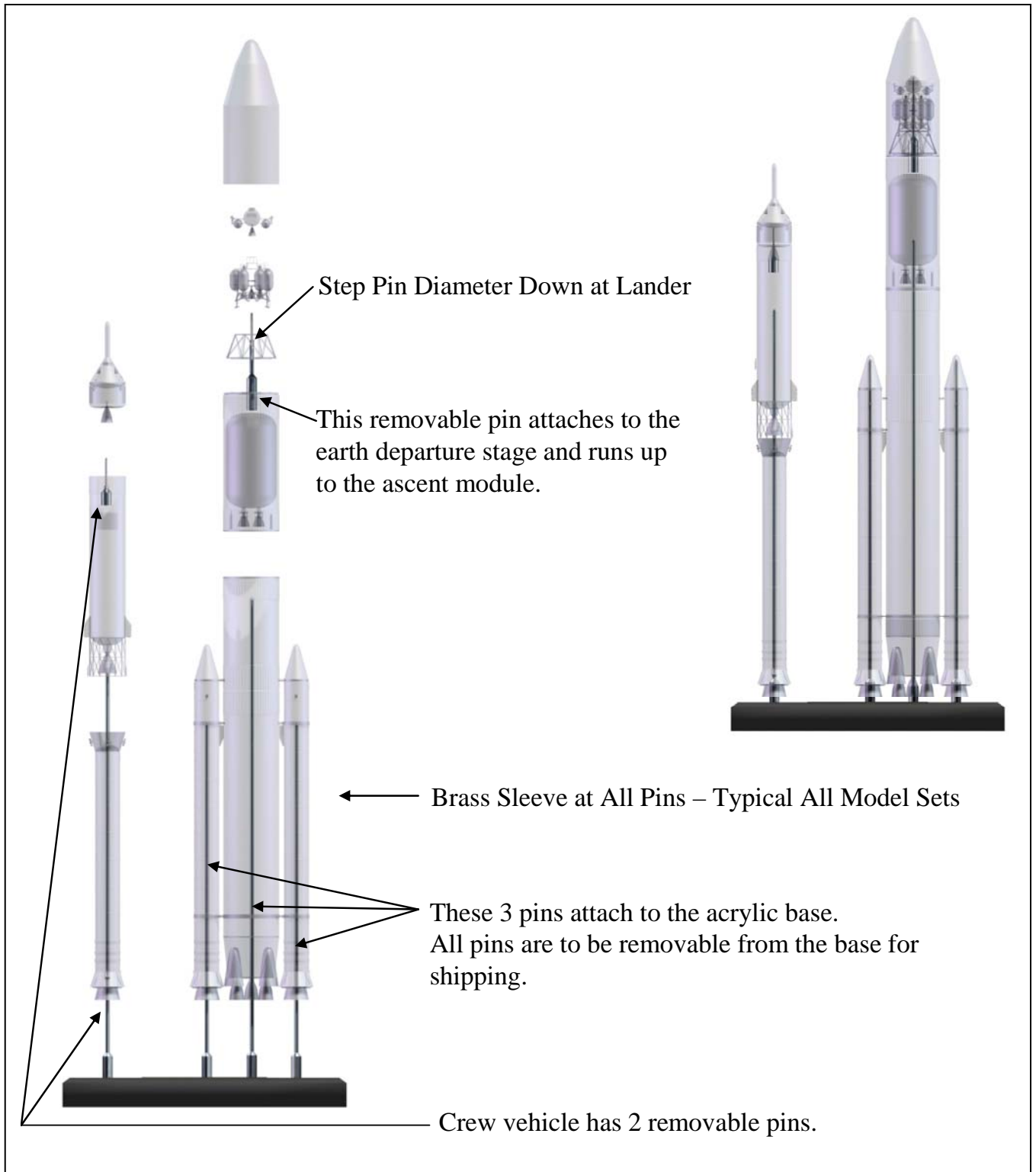

Model Set B – Figure B.6
 Cargo Launch Vehicle Colors, Textures and Decals

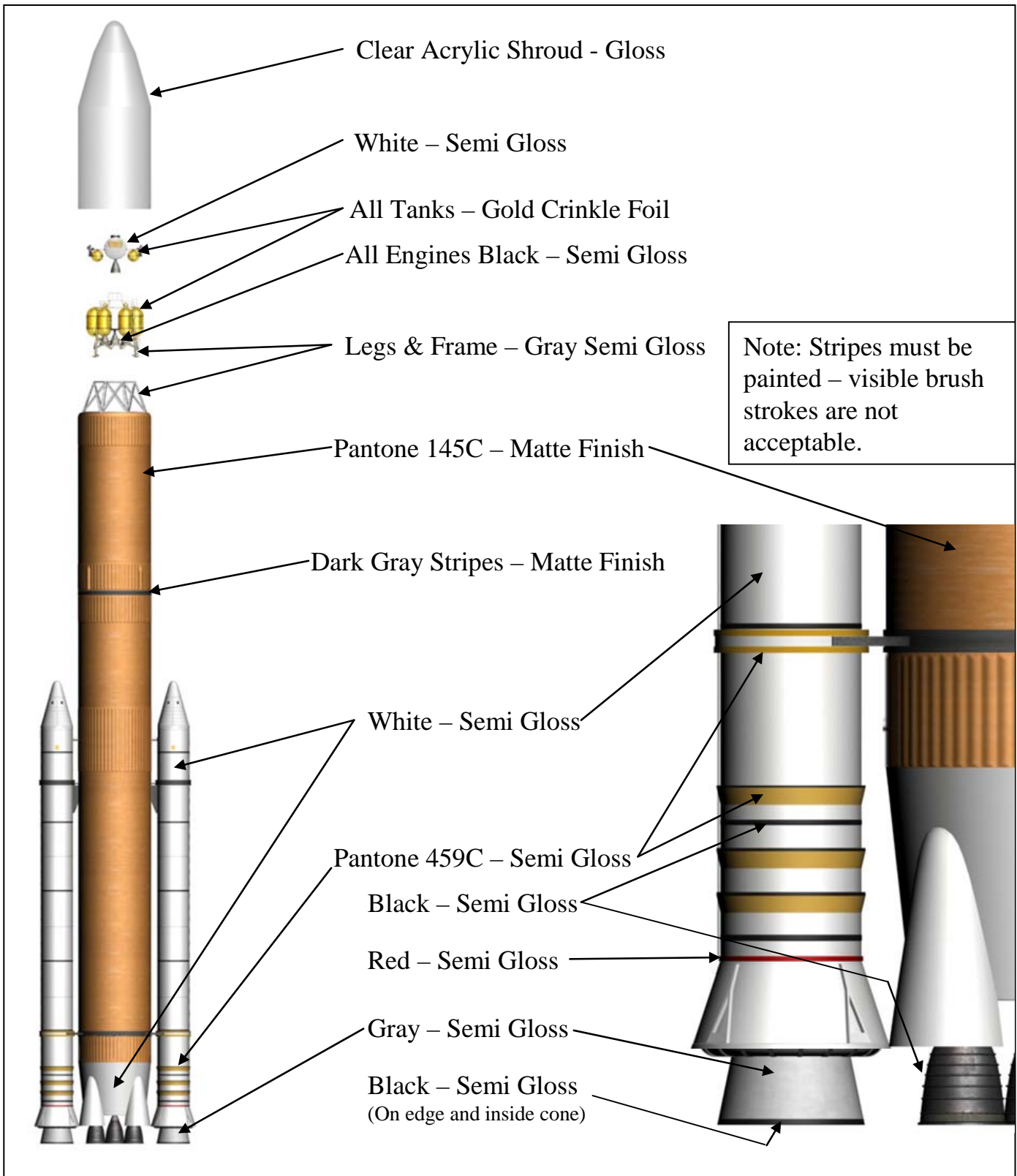

Model Set B – Figure B.7

1:144 Scale

Crew Launch Vehicle Overall Dimensions

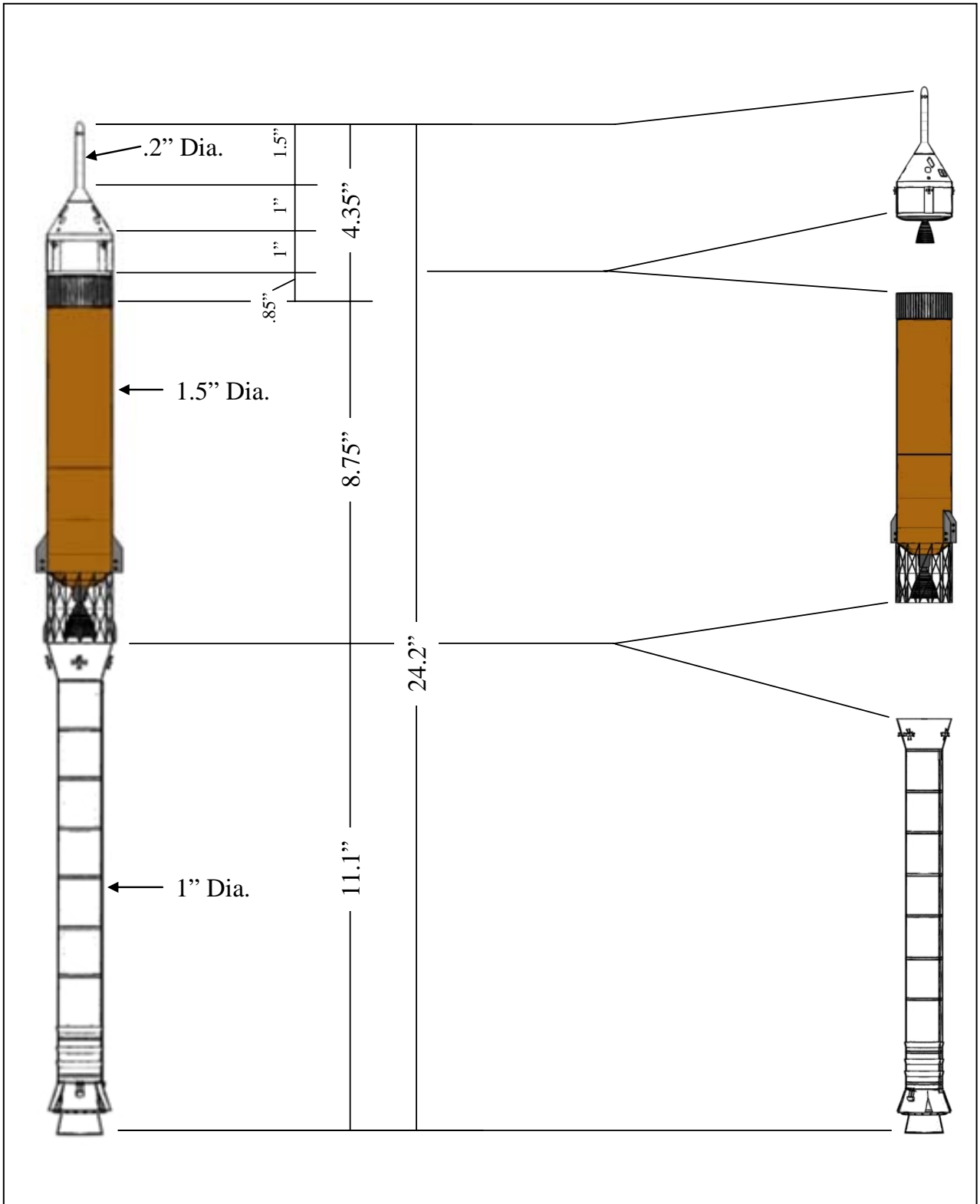

Model Set B – Figure B.8
 Crew Launch Vehicle General Details

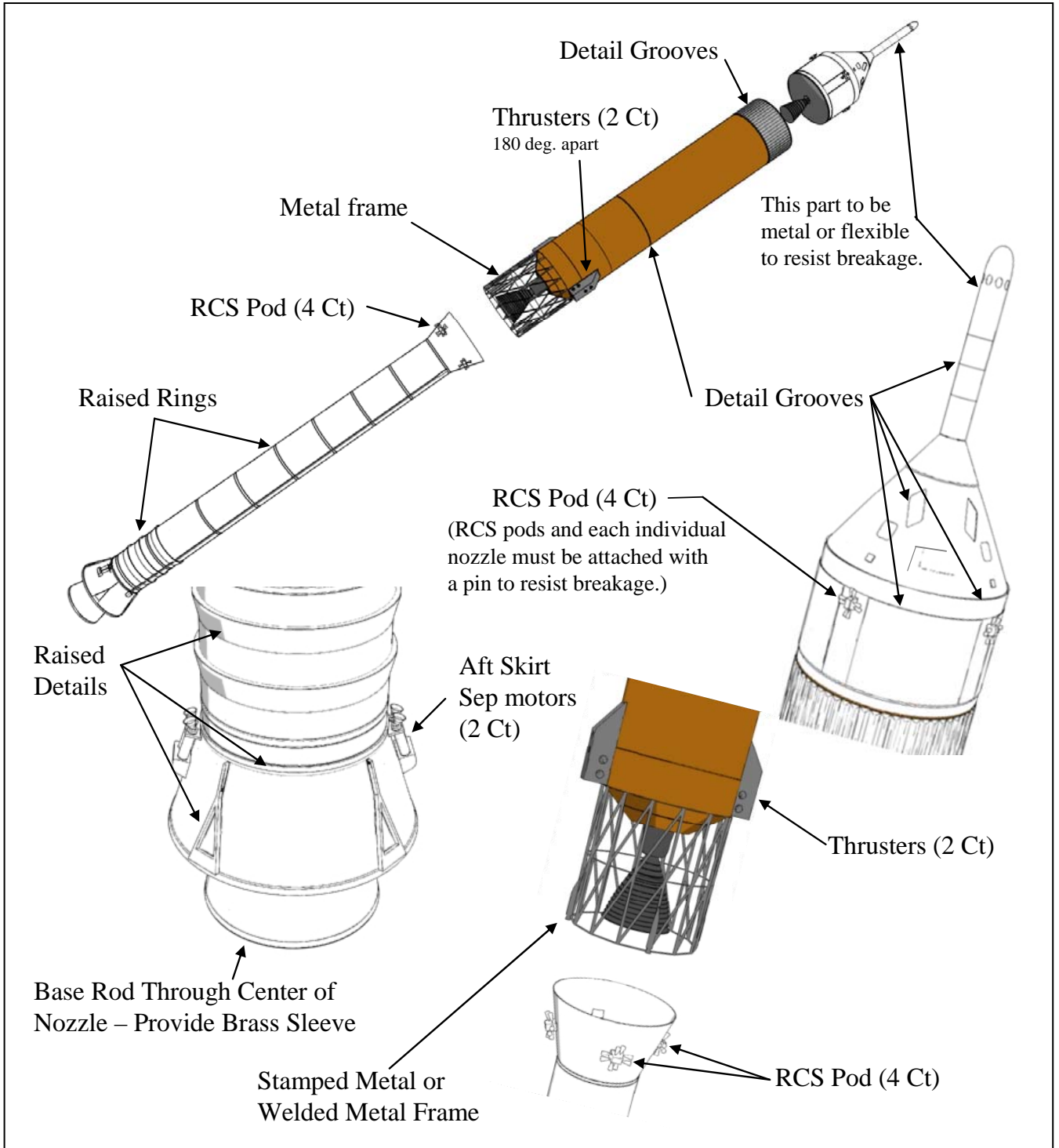

Model Set B – Figure B.9
 Crew Launch Vehicle Colors, Textures, and Decals

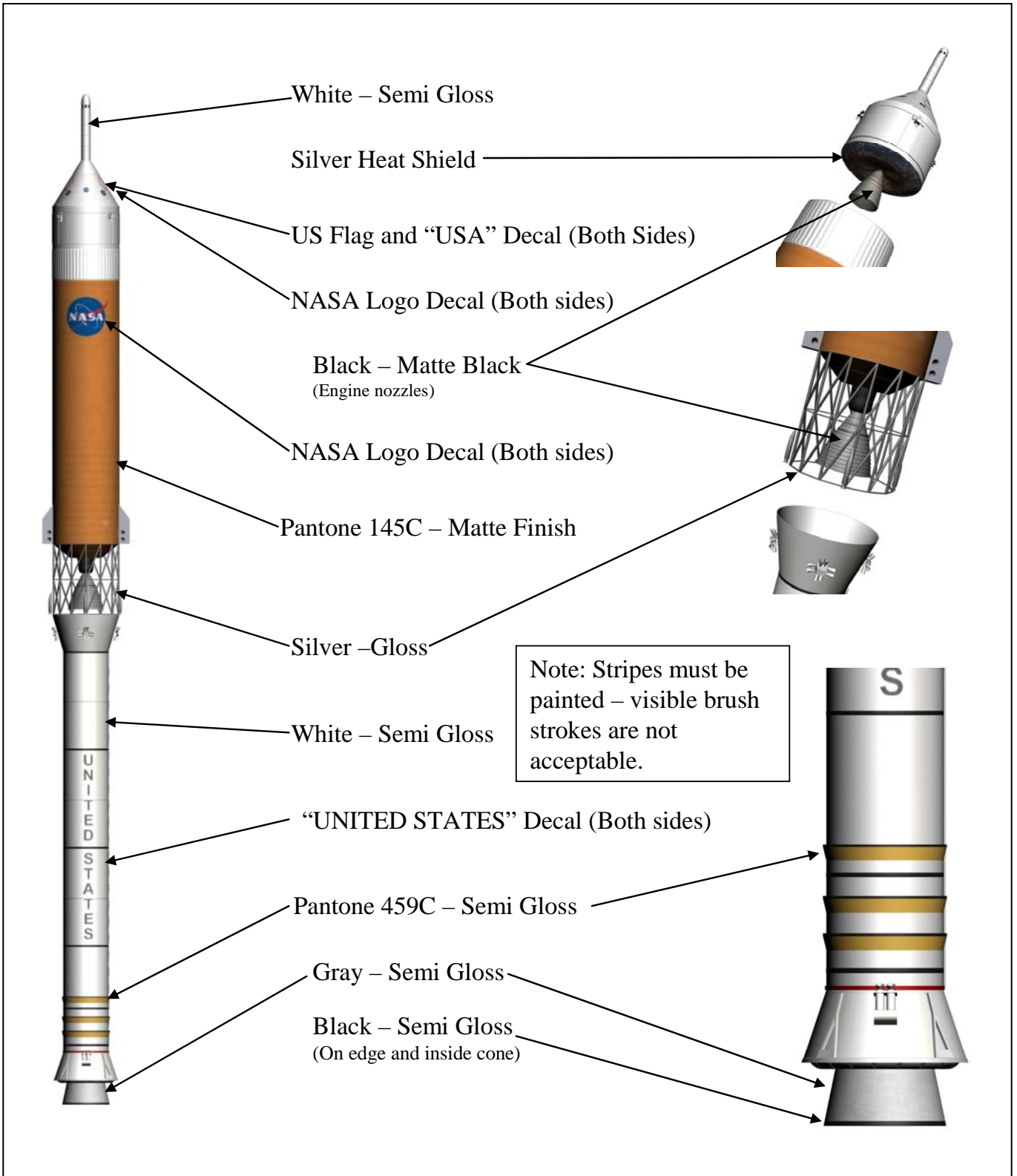

Model Set B – Figure B.10
Box Details

Case Details:

Each model is to have a rugged plastic case suitable for airline travel as shown below. The interior of the case should have custom molded foam padding. Each is to have a laminated label on the exterior similar to that shown in Figure A.8. Case of impact resistant plastic by Pelican or Equal.



Model Set C “MOBL-MODS”

1:144 Scale High Fidelity Launch Vehicle Model Set – Ruggedized for Travel

Overview of Contents.

Each Model Set C is to include an Acrylic base, Removable Cargo Launch Vehicle, removable Crew Launch Vehicle, and rigid airline case.

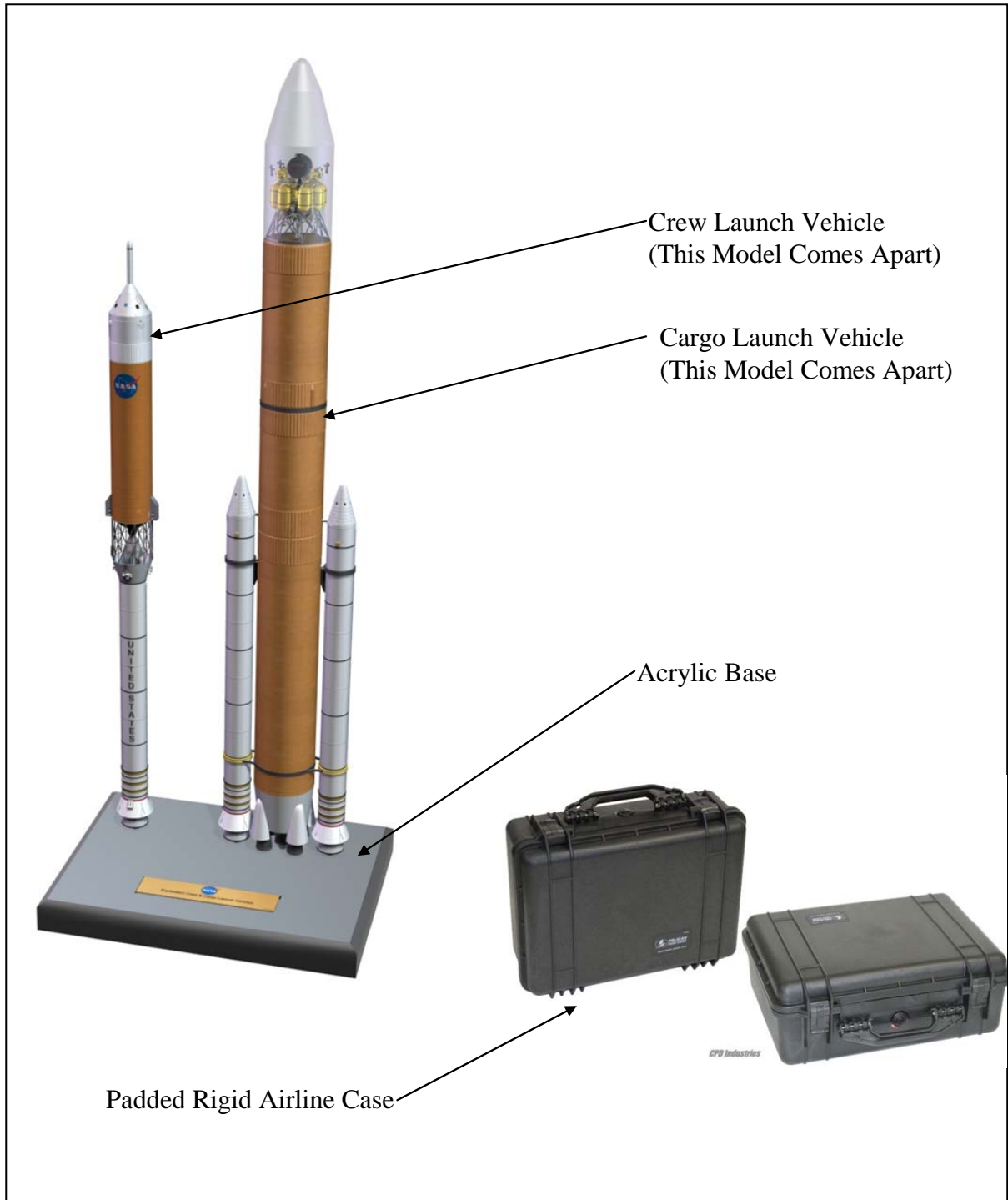

Model Set C – Figure C.1

Model Overview

Model design is the same as Model Set B except the construction is to be much stronger both in design and in packaging.

Model Construction:

All parts are to be constructed of metal except for the transparent acrylic shroud. Other exceptions will be considered provided it doesn't detract from its durability.

Part Finish:

All parts are to have a highly durable paint such as epoxy or powder coating.

Case Details:

Each model is to have a rugged plastic case suitable for airline travel as shown below. The interior of the case should have custom molded foam padding. Each is to have a laminated label on the exterior similar to that shown in Figure A.8. Case of impact resistant plastic by Pelican or Equal.



Model Set D “BOX-MODS”

1:288 Scale Low Fidelity Launch Vehicle Model Set

Overview of Contents.

Each Model Set D is to include an acrylic base, Removable Cargo Launch Vehicle, removable Crew Launch Vehicle, and a padded corrugated box. This model Set is the same as Model Set A except the sale is 1:288.

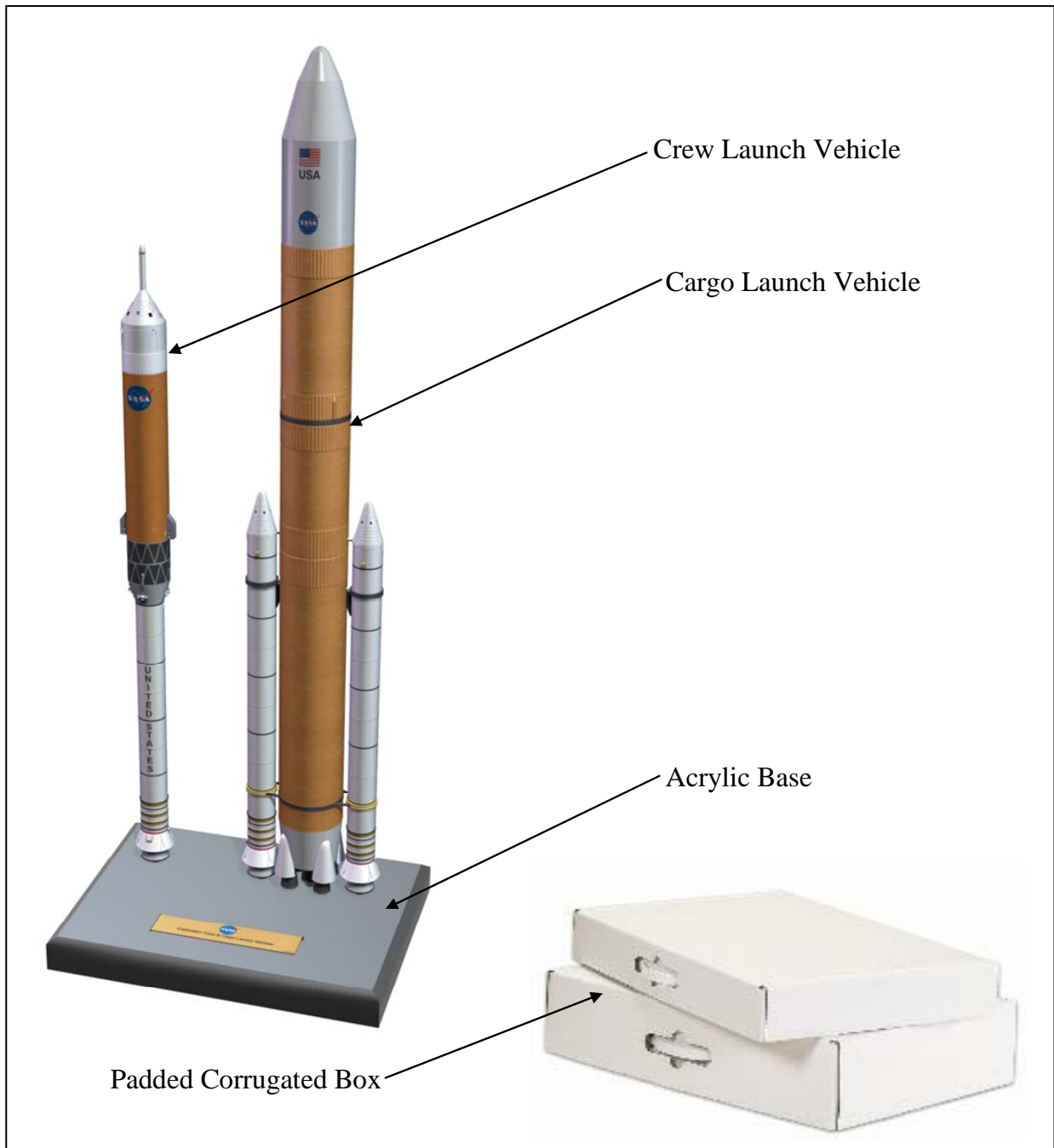

Model Set D – Figure D.1
Box Details



Each models set to have a corrugated box similar to that shown in Figure D.1 above. Each box is to include a white adhesive laser printer color label similar to that shown on Figure A.8 of approximately 4” wide. Each box should have “Fragile” visible on all 6 sides of the box. The interior of the box shall be padded sufficiently to allow the models to be transported and shipped without damage. The base and models are to fit within one box. The box size and configuration is to be determined by the contractor and approved by the government.

Model Set E

1:48 Scale High Fidelity Lander and Capsule Model Set

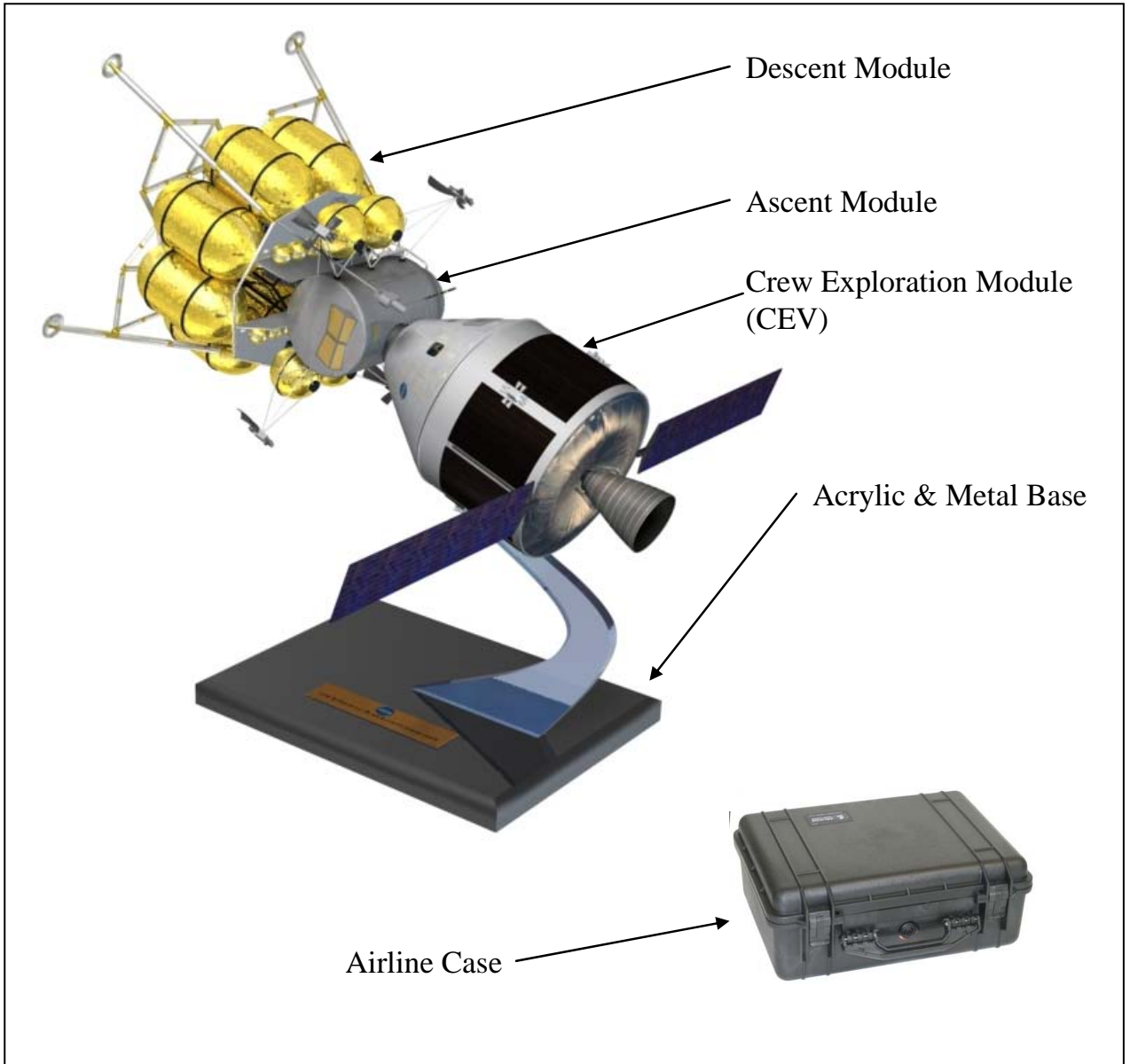

Model Set E – Figure E.1
1:48 Scale
Lander and CEV Overall Dimensions

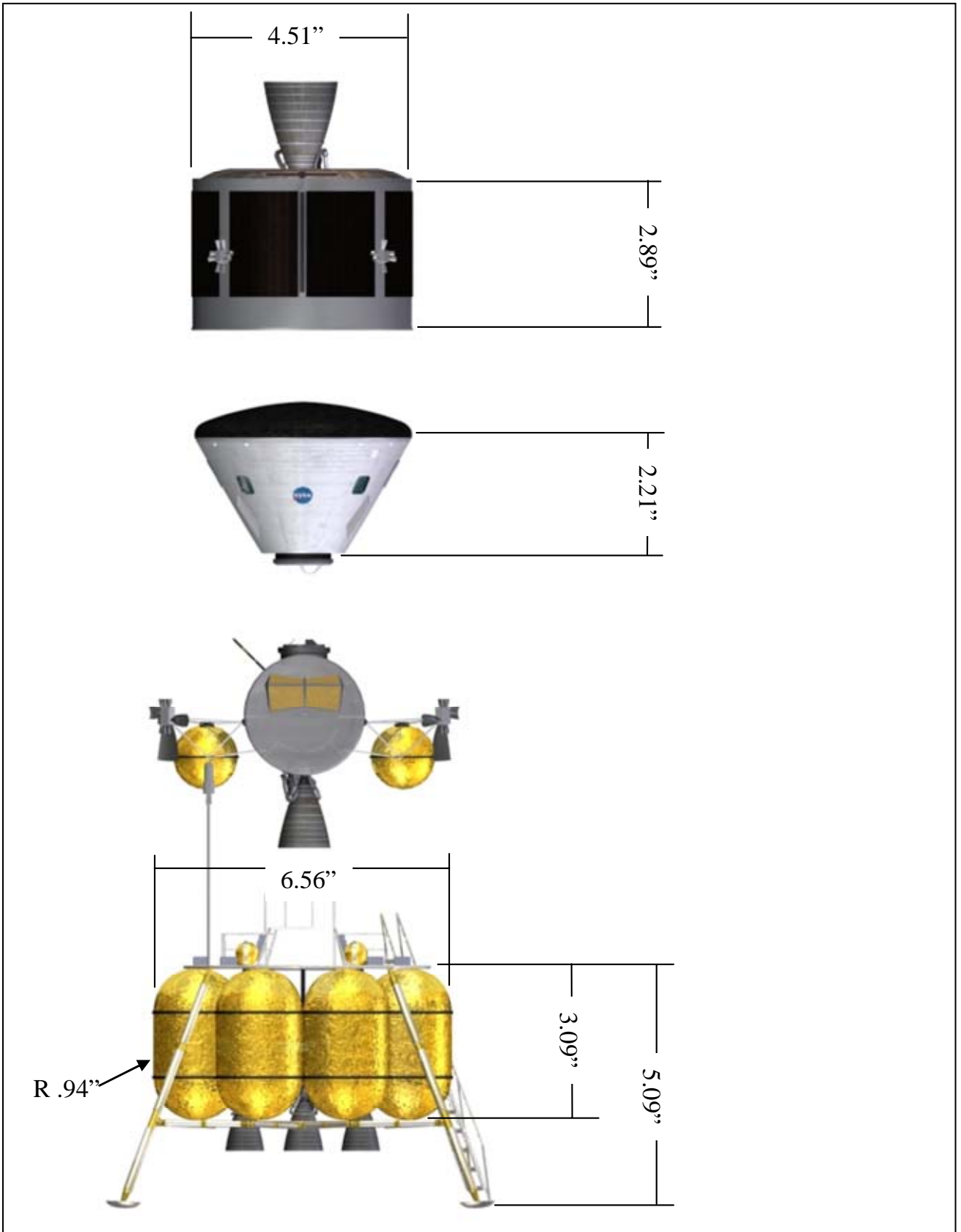

Model Set E – Figure E.2
Lander and Capsule Model Components

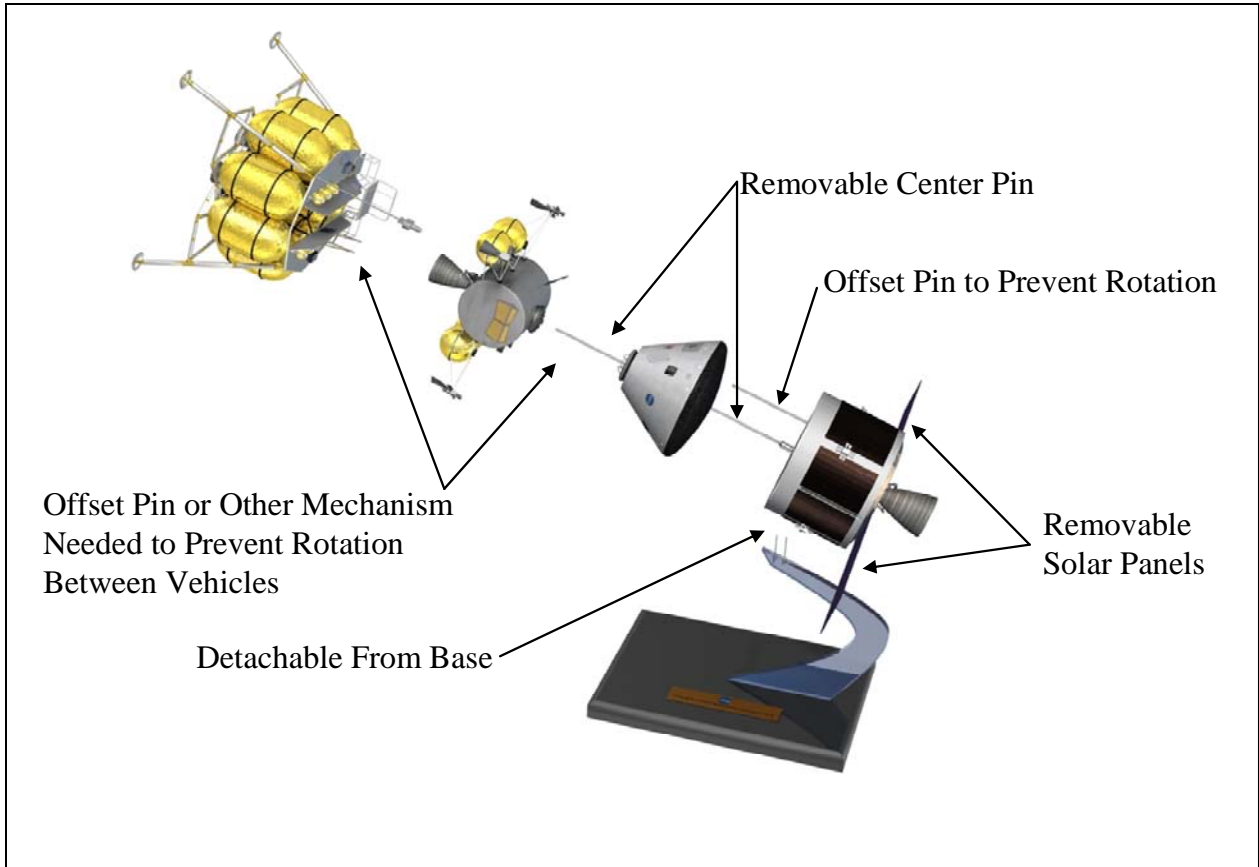

Model Set E is comprised of the detachable components as illustrated above. This model should be strong enough for the Descent Module to be placed on its feet and support the Ascent Module and CEV. The Design should anticipate this configuration and provide a physical mechanism such as a pin for stability and continuity.

Model Set E – Figure E.3
1:48 Scale
Ascent Module Details

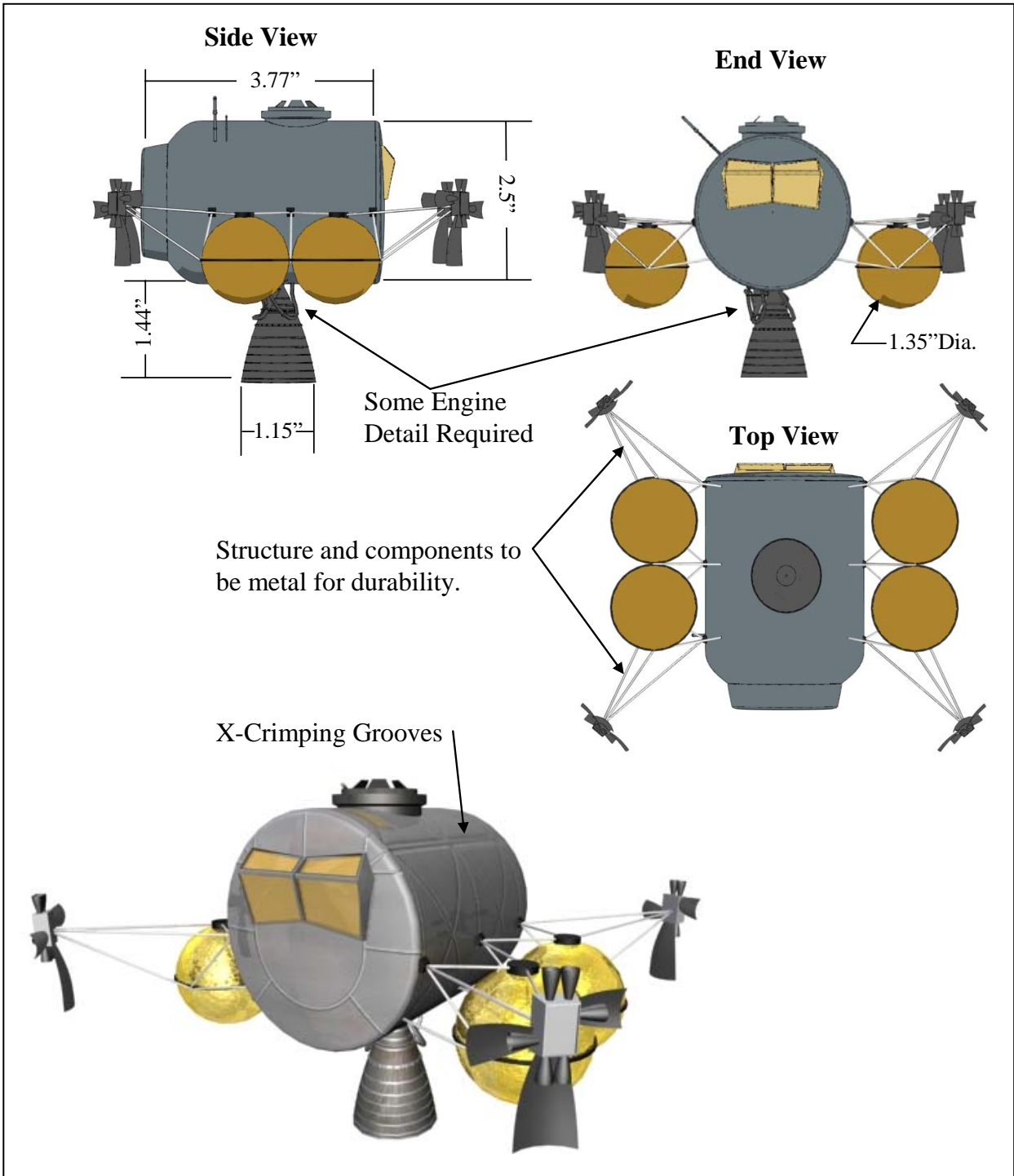

Model Set E – Figure E.4
Descent Module Details

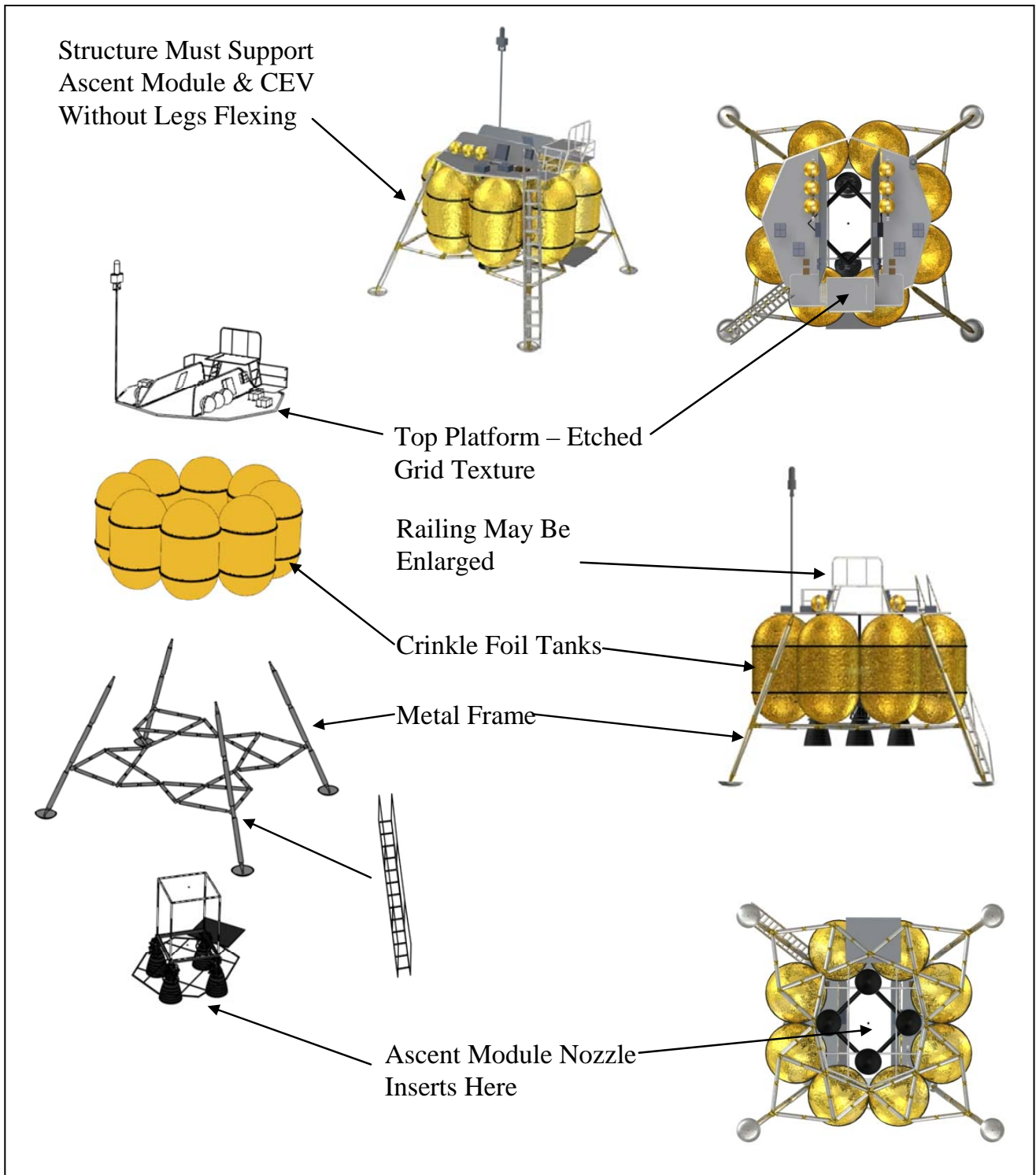

Model Set E – Figure E.5
CEV Details

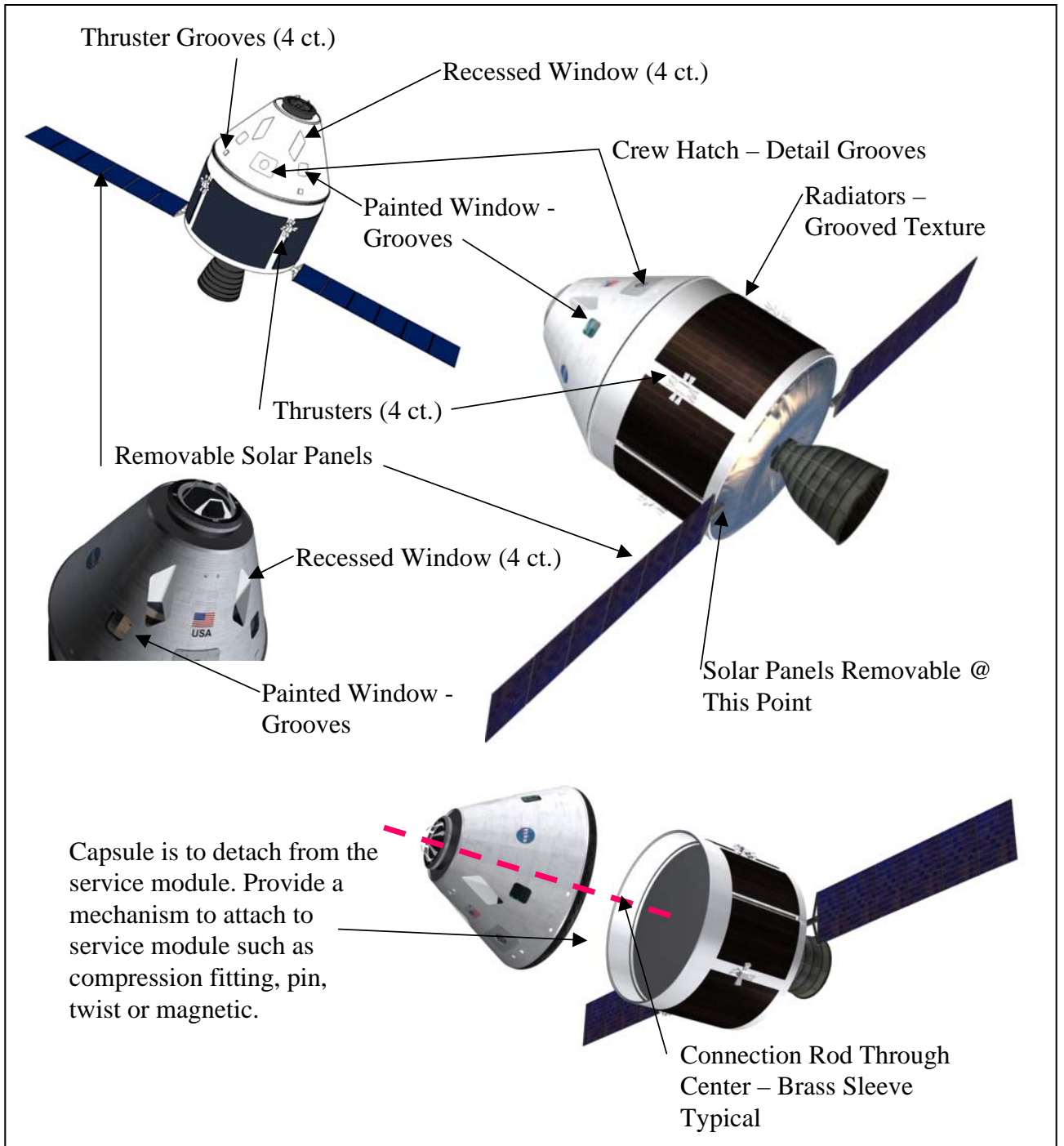

Model Set E – Figure E.6
 Lander and Capsule Colors, Textures, & Decals

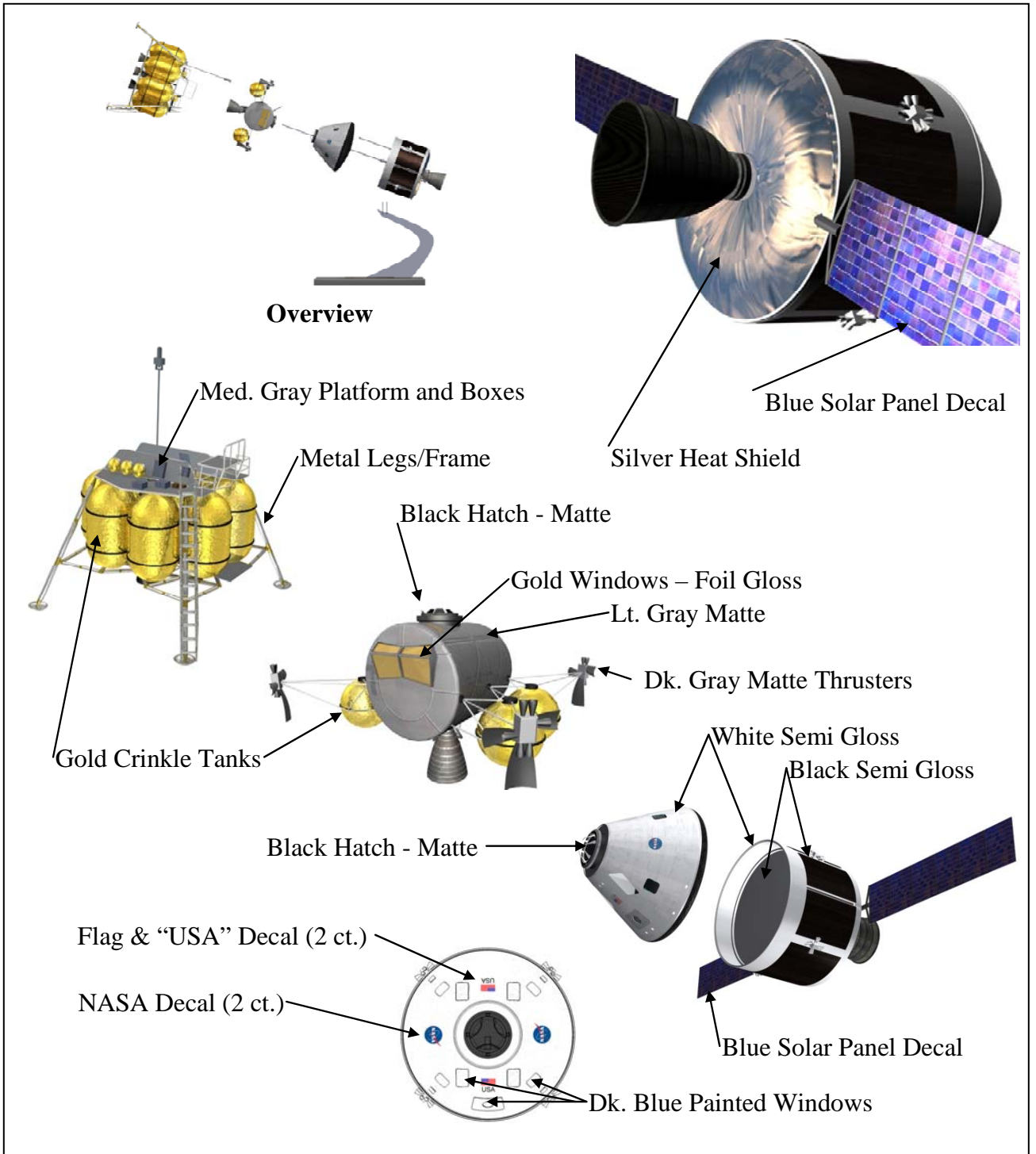

Model Set E – Figure E.7
Base Details

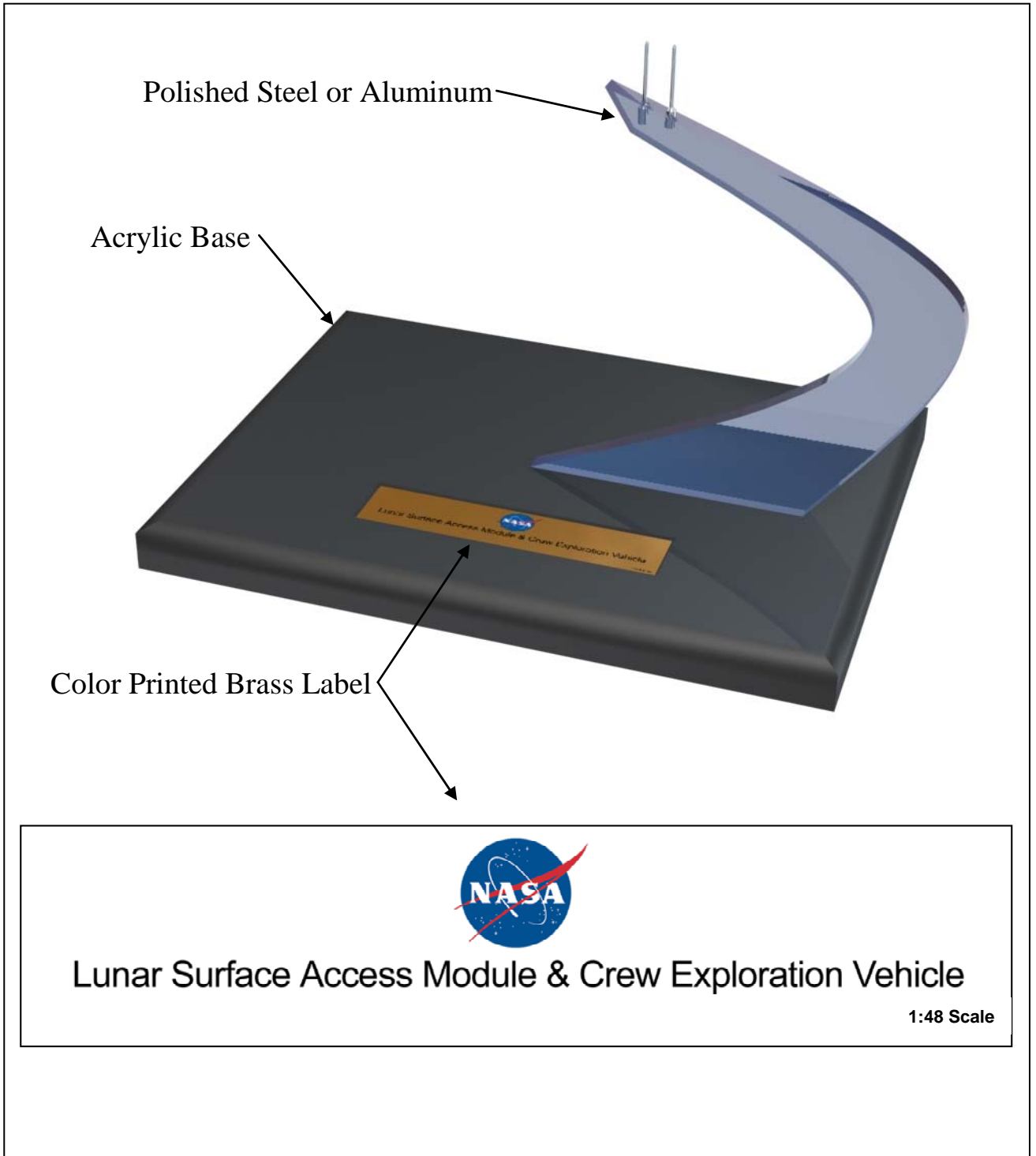

Model Set E – Figure E.8

Case Details

Each model is to have a rugged plastic case suitable for airline travel as shown below. The interior of the case should have custom molded foam padding. Each is to have a laminated label on the exterior similar to that shown in Figure E.7. Case of impact resistant plastic by Pelican or Equal.

