

FOCUS ON

ENGINE MANUFACTURING

Excitement surged through the world like an electric shock back in 1957 when Sputnik I was launched. It was the beginning of the Space Age. Young people throughout the world decided over night to join the race to space by creating their own rockets and concocting their own fuels. However it turned out to be a deadly game. Many were seriously injured, even killed, by their own experiments.

It was a genuine concern for these young space enthusiasts and future scientists that prompted Vern Estes to use his skill and "know how" to create the first safe mass-produced model rocket engine. As this small solid propellant engine became the very heart of model rocketry so the Engine Manufacturing department is the very heart of Estes Industries.

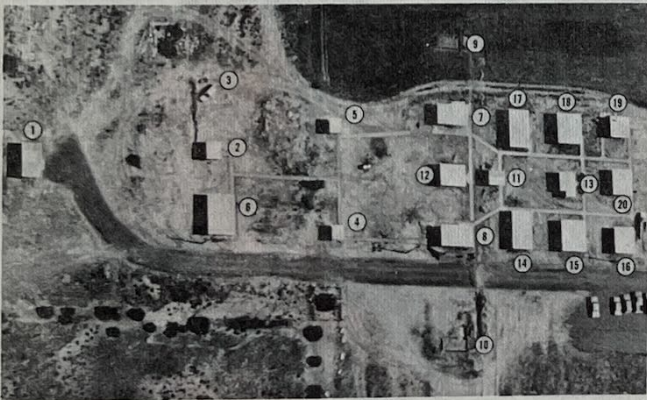

Fuel chemicals are taken from storage (1) to a small preparation building (2). Here the solid propellant is prepared. The components are mixed automatically (3), then taken to storage buildings (4 & 5) where the propellant is kept handy for use in the engine making machines.

The smoke tracking and delay element is prepared in a larger building (6). It requires the mixing of precisely measured chemicals. The types of chemicals used and the quantity of each has been carefully determined. In fact, controlled experiments to improve fuel and delay are a regular task of the department.

The engine making machines have been christened "Mabel". The original machine, Mabel I (7), is completing her tenth year of duty. Having manufactured nearly 8 million engines for model rocketeers she will probably be retired at the end of this year. Mabel II (8) went to work in October 1967. Buildings are being erected (9 & 10) for Mabel III and IV. At least one of the these machines may be in operation by the time you read this article.

As a safety precaution for our workers, the electrical equipment, heating units and air and hydraulic power supplies are separated from each Mabel by a concrete partition. This is to help insure the safety of the operator. Each machine is designed so its operator will be safe regardless of what goes wrong.

While the Mabels are very complicated machines, an explanation of what happens is fairly simple. An empty casing is fed onto the machine. Next the nozzle is inserted. This is followed by the solid propellant, delay element and ejection charge. The end cap is slipped into place. A sensor checks whether the engine contains the proper amount of fuel and other components. If all is well it bounces into a bin of completed model rocket engines; if not, it automatically falls into the reject bin. All reject engines are promptly destroyed to assure that no defective engine will be used.

About three engines out of every 100 are tested on the static thrust stand (11) which is located near the compressor building (12). Placed in an engine holder they are electrically ignited. A sensitive 4 element strain gauge detects the thrust from the engine. This signal is amplified and then read out on calibrated meters and charts.

Readings taken from this electronic integrator indicate to the Estes engineers the peak thrust, thrust duration, total impulse, and the power of the ejection. If the engine does not meet specifications, adjustments are made on Mabel until all engines are correct.

The completed engines are taken to the print building (13) where they are printed with the correct labeling. Most engines then go to storage (14, 15, 16, 17 and 18). However, some of them are destined to become Series II and III engines. This requires special equipment and processing in building 19.

The office and lunch room (20) complete the Engine Manufacturing department.

The preparation of model rocket propellants and engines is not for amateurs. The crew in this department, under the capable leadership of Delbert Buchanan, are skilled craftsmen with extensive training using highly specialized equipment under extraordinary safety procedures.

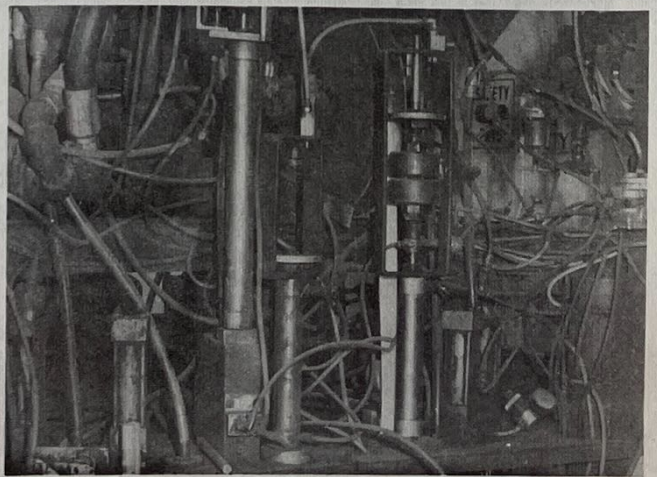

The complexity of equipment to manufacture model rocket engines is indicated by this portion of Mabel II. Shown are some of the air and hydraulic components and circuits which perform control, measurement and handling functions.

Ignition Tips

by Arlene Wheeler



One cause of much trouble to many beginners and some experienced rocketeers is ignition. Although not all ignition problems have the same solution, most of them do result from one of three basic errors.

The first cause of trouble is the similar appearance of photoflash and flashlight batteries. (Actually, these are "cells"—a battery is a group of cells.) Since they look so much alike many rocketeers seem to feel they will work alike. This is not so. Flashlight cells are made to deliver a steady flow of low power which is fine for lights and small motors. Fresh, new flashlight cells

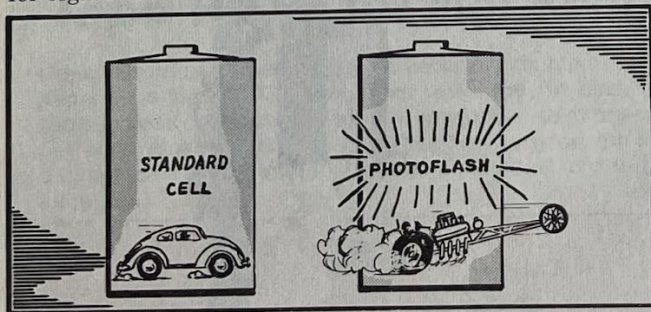

Contest Activity Reaches New High!

Members of the Estes Industries Contest Board report that Design Contest participation has reached a new record high with the Design of the Month Contest. Because of the interest shown, this contest will continue to be held each month. For details on entering, see Vol. 8, No. 1 of the Model Rocket News.

In addition to the three main winners to date, 8 extra merit awards have been presented. It is anticipated that more special merit awards will be presented due to the high quality of the entries.

Contest Board members also announce that the annual Science Fair Contest will be held again in the coming year. Full details on this contest will be published in the next issue.

may produce enough current for ignition once, possibly even three or four times, but aren't capable of continued service. Only photoflash cells are able to supply the surge of high amperage power necessary for repeated trouble-free launches. Although the initial cost of proper cells may seem high, the improved performance and long life more than make up for the cost difference.

A second common complaint is igniters that "burn without igniting the engine". There seems to be a misunderstanding about the function of igniters here. If an



igniter "burns" it has performed the function for which it was made. The burning igniter will not, however, ignite the engine unless it actually touches the propellant grain. It's the rocketeer's job to install the igniter where it belongs and to make sure it will stay there.

Some rocketeers are able to overcome this problem by using an alternate method of igniter installation. They bend and insert the igniter in the normal manner, making sure the bent end goes "all the way in". But

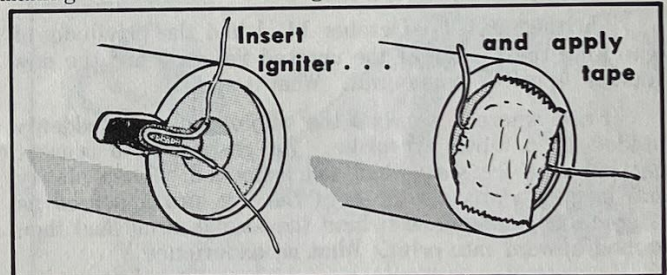

then, instead of tamping wadding in, they spread the leads and apply a square of masking tape to the nozzle and leads as shown. The eraser on the end of a pencil is good for pressing the tape securely into place.

When "It just sits there..."

The third type of problem is the launcher which tests perfectly (see paragraph 2 of "misfires" in the engine instruction sheet) but does nothing at all when a model is on the rod and hooked up. This problem is most often due to a "short circuit". When the micro clips both touch the rod or blast deflector the current flows from a clip, through the rod or deflector, and back to the other clip without bothering to go through the igniter. Supporting the model up off the deflector with a rock, engine casing, etc. is the best way to cure this problem.

If the launcher itself is correctly constructed any ignition failures will usually be due to one of the three causes mentioned. If beginning rocketeers will carefully study each step of the engine instructions and practice following them in detail their percentage of successful launches will be greatly increased.

Maximum reliability and faster ignition will be obtained if a 12 volt system is used. The standard electrolaunch can easily be converted to an eight cell-12 V. system. The ultimate in ignition power can be obtained using an FS-5 (see catalog) with a 12 V. car battery.

NOTES FROM THE BOSS

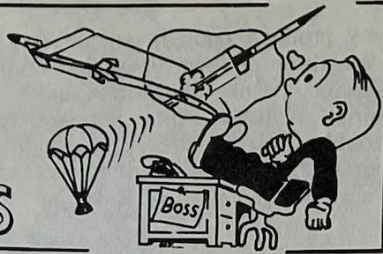

Look carefully at the picture. The objects inside the circles are men. They look small because the rocket is so big. Yes, this is it—the largest rocket ever built by man—the Saturn 5, and this is the way it looked on October 10, 1968, as it sat on the pad being prepared for launch late in 1968 or early '69.

When I first saw this bird it didn't look so big—then I was told we were still eight miles away. As we drove closer and closer the rocket appeared to keep growing until when standing near its base its height was almost unbelievable. No wonder this bird will have no trouble putting a man on the moon—once he's up in the capsule he's practically half way there.

My NASA guide told me the "Mighty Five" stands over 365 feet tall, lifts off with 7 1/2 million pounds of thrust and consumes over 30,000 pounds of kerosene and liquid oxygen per second. According to my calculations that thrust is the approximate equivalent of a cluster of 5,500,000 C6-0's.

On the next day—October 11, I had the privilege of watching the launch of the uprated Saturn 1 and the now famous Apollo 7 spacecraft. What a sight!!

From where I watched the whole pad was suddenly hidden by a cloud of smoke. We gasped for a moment not knowing for sure what had happened. Then slowly and magnificently the nose of the big bird appeared as it gracefully rose from behind the smoke cloud and then arched upward into orbit. What an experience!!

Sometime in the next few months I'm going back. This time it will be to see the lift off of the "Mighty Five". Perhaps it will be the first manned flight when Astronaut William Anders is in the Capsule.

It was great seeing the Saturn 5 on the pad and a thrill to see the 1-B lift off. However, one of the highlights of the trip was accidentally meeting Frank Cox, Charles Coates and Jerry Byrnes, all Estes Model Rocketeers who had come to the cape to see the launch.

I also hope to be there at another time in the future, when one of our young model rocketeers finishes college, becomes an astronaut, and lifts off on his journey to explore the unknown. If this should be you, and if you'll let me know about it, I promise you I'll be there.

Vern

MODEL ROCKET NEWS

© ESTES INDUSTRIES 1968

The *Model Rocket News* is published by Estes Industries, Inc., Penrose, Colorado. This publication is written for America's model rocketeers to promote safe youth rocketry, distribute current technical information and make model rocketry more enjoyable and educational. Current issues of the *MRN* are distributed free of charge to all active Estes customers.

Vernon Estes
Publisher

Gene Street
Chief Illustrator

William Simon
Editor

4

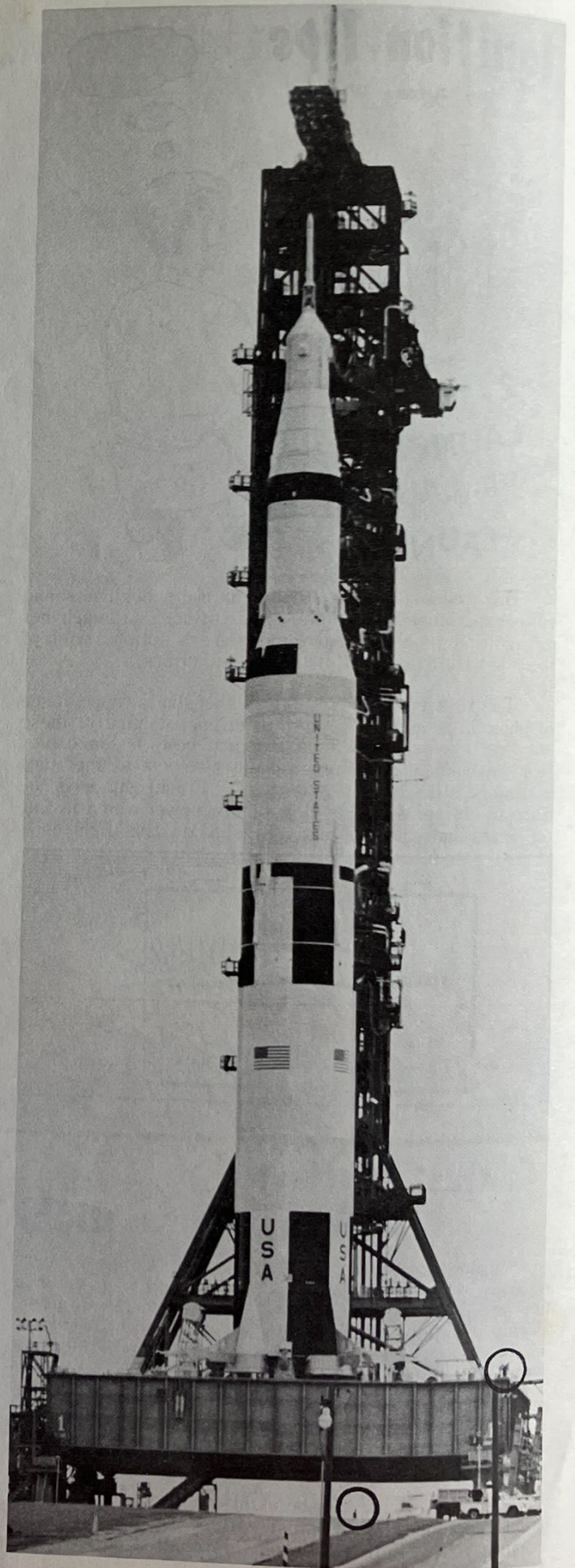

THE IDEA BOX

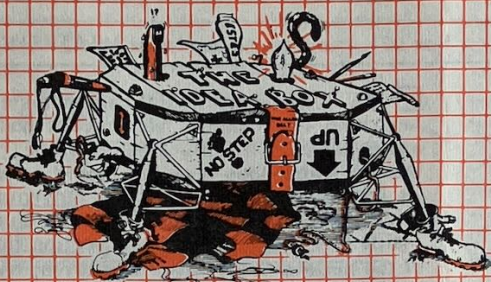

Plastic Pill Bottle Provides Practical Igniter Storage

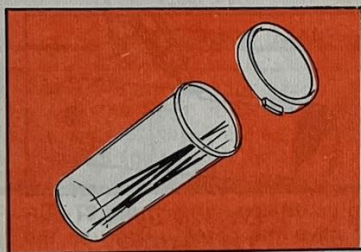

A standard plastic "pill bottle" at least 3" long and 3/4" to 1" in diameter is excellent for storing pre-cut igniters in your range kit. This suggestion comes from Bill Riddle of Garner, North Carolina.

Tape Paper for Flat Roots

Dennis Held of Harvard, Illinois recommends taping sandpaper to a flat surface. . . then move the fin back and forth across the surface of the sandpaper to produce a perfectly flat root edge. (This method is good for producing an evenly tapered or beveled leading or trailing edge too.)

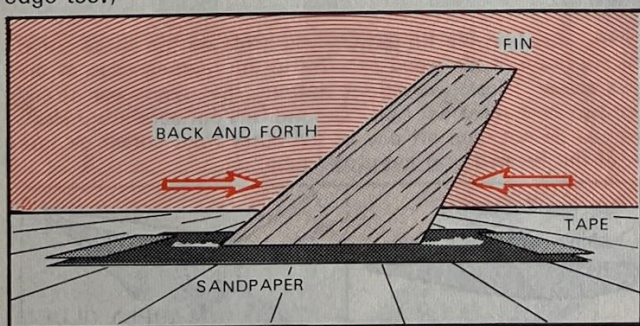

Range-in-Use Flag

John Cieslak of Itasca, Illinois uses an Estes Iron-on patch applied to each side of a triangular piece of fluorescent red-orange cloth. John says such a flag makes a good club flag as well as a wind direction indicator, in addition to letting everyone in the area know the range is in use.



Simplified Hookup for a 3-Engine Cluster

Frank Cunningham of Grand Rapids, Michigan modified his 4-engine Saturn ignition system to handle 3 engines easily. Frank says that he's getting better ignition reliability than ever before with this hook-up system.

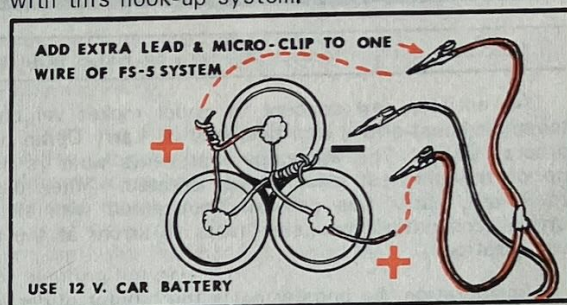

Attention: Home-builders "Fail-Safe" Launch Button

A safety item for use on home-built launching panels is suggested by Stephen M. Byan, Jr. of Baltimore, Maryland.

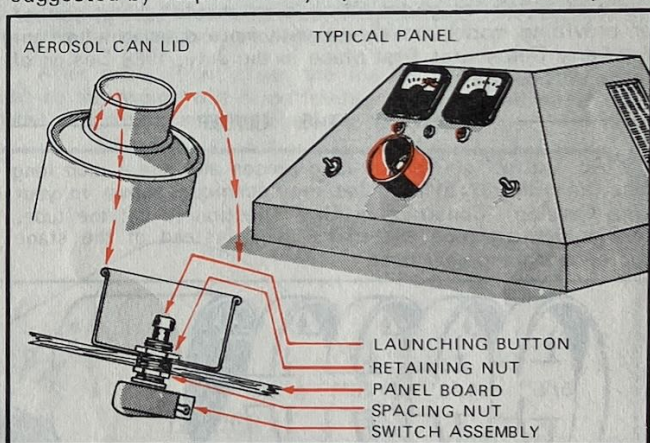

When mounting the launch button (such as the SWM-1 switch) also drill a 1/2" hole centered in the top of an aerosol can lid as you drill the 1/2" hole in the panel. Install the switch shaft through the panel from the underside, invert the cap and install it over the switch shaft followed by the retaining nut as shown. Thus protected, your launching button is less likely to be accidentally pressed prior to reaching the end of a countdown.

PAINT CORNER

EASY MIXER

Bill Pease of Indianapolis, Indiana submits an easy way to mix bottle paint. Drop a ball bearing into the bottle, recap the bottle and shake.



SMO-O-OTH FINISH

John Nielsen, Twin Falls, Idaho, says a smoother finish is obtained by rubbing the last sealer coat with fine steel wool. The first coat of the finish color should also be rubbed lightly with fine steel wool, according to John.



JUST IN CASE. . .

Estes Industries Rocket Plan No. 56

FLYIN' STOVEPIPE

BOOST GLIDER
by
Larry Deran

Published as a service to its customers by Estes Industries, Inc., Box 227, Penrose, Colorado 81240 © ESTES INDUSTRIES, 1968

An entirely new concept in model rocket vehicles, the Stovepipe boost-glider was designed by Larry Deran of Santa Barbara, Calif. The Stovepipe represents what is probably one of the simplest gliders ever created. When designing his model, Larry was primarily concerned with the glider portion, conducting extensive tests to arrive at the present configuration.

In operation the booster pulls the tubular glider into the air. The fins on the booster spin the vehicle, averaging out any assembly misalignment and providing a straight upward flight. At ejection the shock of the engine hitting the hook forces the booster rearward, out of the tubular glider. The booster tumbles to earth while the pipe glides back.

Because the Stovepipe is a new concept, it opens many areas to the experimenter. What, for example, is the best booster design? What is the effect of airfoil on the performance of a tubular glider? What size should the glider be? For providing model rocketeers with more questions to answer, Larry Deran wins first place in the July, 1968 Design of the Month Contest.

BUILDING THE GLIDER

- 1A. Cut off six 1/2 inch long pieces and one 4 inch long piece from the BT-101K. Use the technique shown in your Estes Catalog "Construction Tips" section to cut the tube. A large mailing tube should be used instead of the stage coupler in making your cuts.

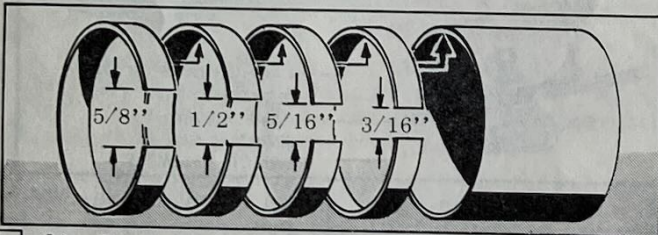

- 2A. Remove a 3/16" wide section from one of the 1/2" long pieces of tube. Glue this piece inside one end of the 4" long tube piece. Hold the piece in place with paper clips until the glue starts to set. Next cut a 5/16" section from one of the remaining 1/2" long pieces. Glue this piece to the inside of the first piece and clamp it with paper clips for a few minutes. Cut a 1/2" wide section from the third piece and glue it to the second. Finally, cut a 5/8" section from the fourth piece and glue it to the third. When this operation is finished you will have an extra-thick (and heavy) wall at one end of the tube. Save the remaining 1/2" long tube pieces for later adjustments.

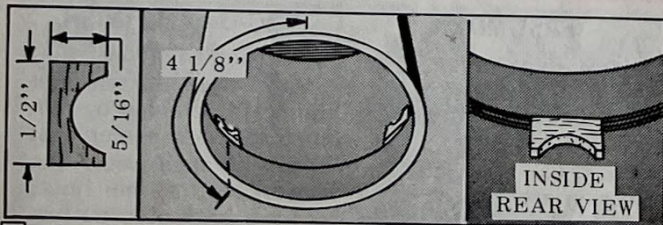

- 3A. Mark three points around the outside of the tube at the top, each point 4-1/8" from the others. Cut out three pieces of 1/8" thick balsa to the shape shown above. Glue one piece to the inside of the tube just below the rings at each mark. The fins of the booster will fit against these pieces at lift-off.

- 4A. The tubular glider can be tested for balance without launching the rocket if you have a good "throwing arm" or have access to a fairly steep hillside. When hand launching the Stovepipe, toss it as you would a football, making it spin as it leaves your hand. If the Stovepipe tumbles instead of glides, even after repeated tosses, glue another ring to the inside of the tube, trimming a section from it to fit the inside of the built-up area. After this dries, try again, adjusting the balance point until a glide is achieved. (Some rocketeers find it easier to launch the model, observe how it acts under actual flight conditions, and then adjust the balance.)

BUILDING THE BOOSTER

- 1B. Carefully trace the fin pattern and tube marking guide onto a separate piece of paper (typing paper will do). Cut out the copies you have made.

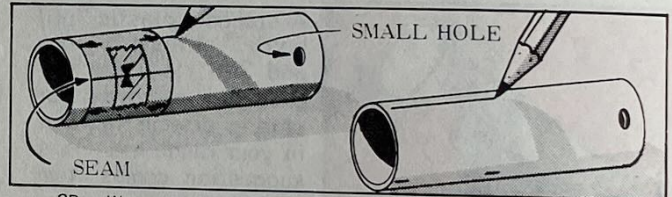

- 2B. Wrap the tube marking guide copy around the BT-30A body at the end that does not have the holes. Position the guide so the small hole in the tube is in line with the seam of the guide and mark the tube at each of the arrow points. Draw a straight line connecting each pair of marks as shown.

- 3B. Place the nose cone in the forward end of the body tube (the end with the holes) and check the fit. If the shoulder of the nose cone is higher than the body tube, sand the entire nose cone until the body line is smooth from tip to tail. Remove the nose cone and smear glue around the inside of the body tube to a 3/8" depth. Insert the nose cone to its shoulder and wipe off any excess glue.

- 4B. Position the fin pattern you made on the balsa sheet with the grain of the wood parallel to the leading edge of the fin as shown. Trace around the pattern, then reposition it and trace two more identical fins. Cut the fins out carefully. Make sure you do not chip off any of the outer front corner as this part of the fin will grip the glider tube.

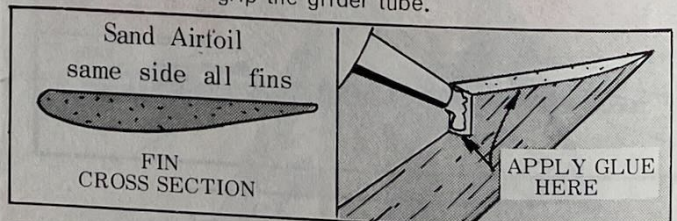

- 5B. Sand the fins to the airfoil shape shown above. It is very important to sand the airfoil on the same side of all fins, since the airfoil is intended to make the model spin, giving a straighter upward flight and a more reliable glide. Do not sand the fin tips; instead reinforce them with glue along the front as shown.

- 6B. When the fins have been sanded to shape glue them to the body. To do this, apply a light coating of glue to the root edge of a fin and press it against the body. The flat side of the fin should be exactly on one of the lines drawn in Step 2B. Repeat this with the other two fins.

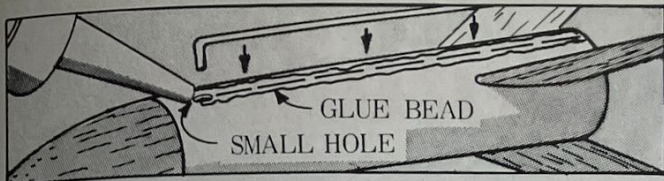

7B. Insert the long end of the engine hook into the small hole in the front of the body, punching through the nose cone as necessary to force the hook all the way in. Remove the hook, squirt glue into the hole and reinsert the hook, positioning it so it runs straight down along the body tube as shown. Apply a thin line of glue to the body and hook, all along the tube, and smooth the glue down with your finger.

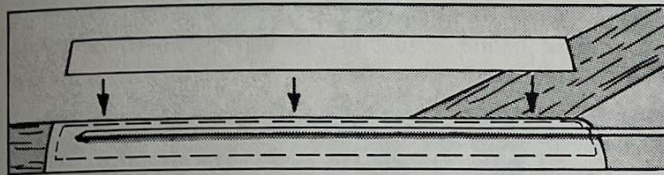

8B. Cut out a piece of typing paper 1/2" wide and 3" long. Apply glue to one side of the paper and press it down into place over the engine hook as shown.

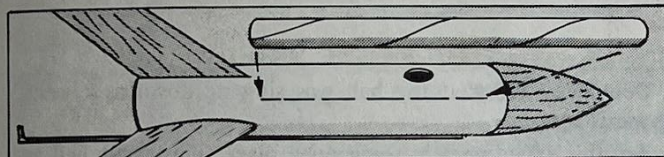

9B. Glue the launching lug to the body tube so its rear is even with the front of the fins and is halfway between two fins as shown. Sight along the tube and align the lug so it runs parallel to the body tube.

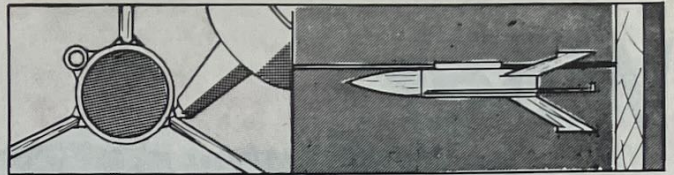

10B. When the first glue on the fins and launching lug has become hard, apply a glue fillet to each of the fin-body joints and to the launching lug as shown. The fillets should be smooth and bubble-free. Support the rocket horizontally while the glue is drying.

11B. Check the fit of the "booster" in the "glider." The three balsa blocks should fit against the fins so the booster vehicle cannot come out forwards. However, the booster should be loose enough so the lightest tap will send it out the rear of the glider. Sand the fin tips (or glue slivers of balsa on) until the booster fits correctly. Check the fit again after painting the model.

FLYING THE STOVEPIPE

When flying the Stovepipe install the igniter in the engine before inserting the engine into the rocket. Wrap a piece of masking tape around the launch rod approximately six to seven inches above the blast deflector to support the model as shown. Place the booster vehicle *alone* on the rod, connect your clips to the igniter, and then slide the glider down over the rod and into place on the booster. Continue with your regular countdown procedure.

After every flight clean the inside of the booster body tube so the engine will slide freely. If the engine sticks the model will not separate and recover properly.

FLYING STOVEPIPE PARTS LIST

- 1 Body Tube--Part #BT-101K*
- 1 Body Tube--Part #BT-30A
- 1 Engine Hook--Part #MH-1*
- 1 Nose Cone--Part #BNC-30D
- 1 Sheet Balsa Fin Stock--part #BFS-40
- 1 Launching Lug--Part #LL-2B

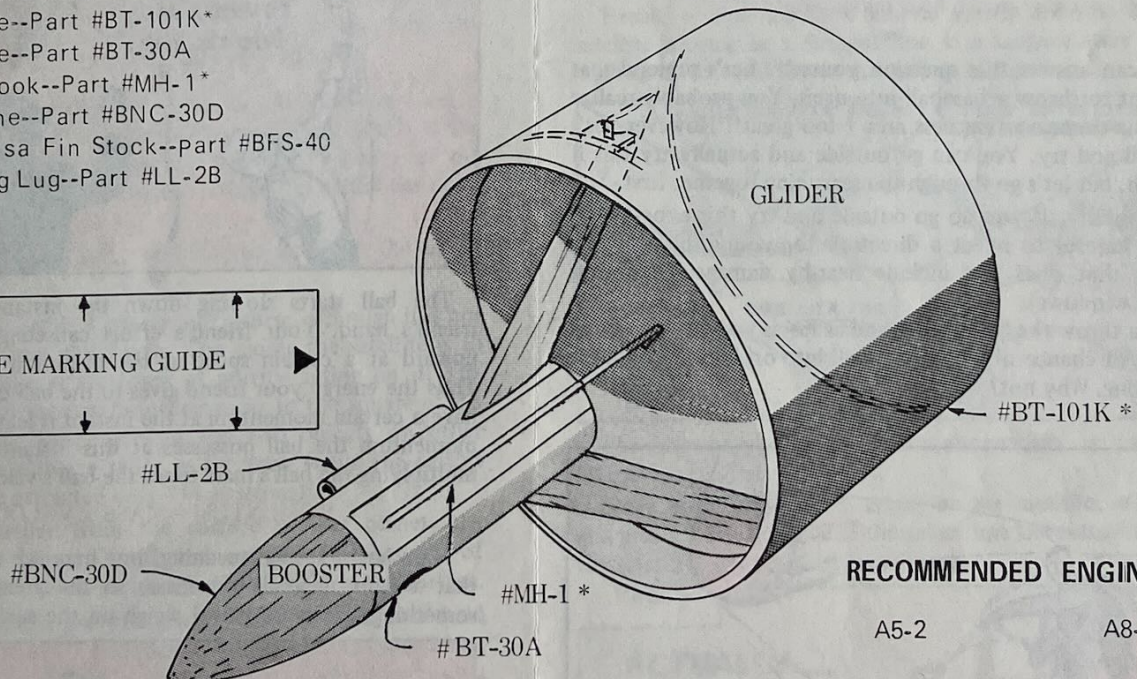
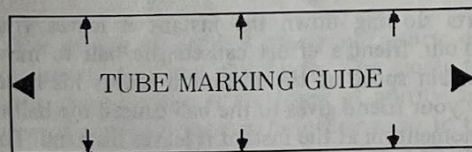

RECOMMENDED ENGINES

A5-2	A8-3
B4-2	B6-4
C6-5	

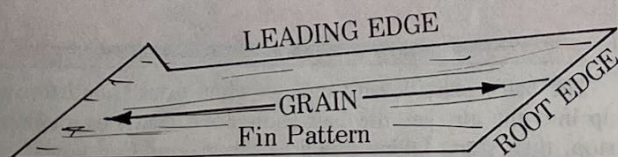

* The BT-101K body tube is available as a special order item. Order by Cat. #682-BT-101K, \$1.00 each. The Engine Hook, Cat. #261-MH-1, is available for \$.15 each. Because these are not regular catalog items, it is especially important to use the correct catalog numbers when ordering.

What Keeps a Satellite in Orbit

By ROBERT L. CANNON

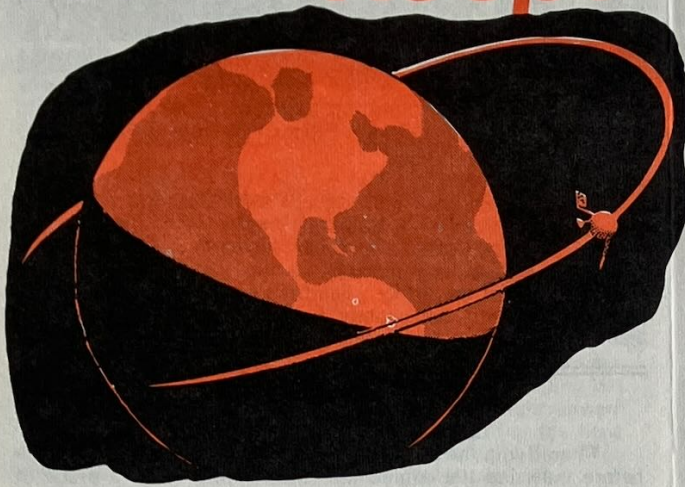

A satellite, according to a dictionary definition is "a man-made object put into orbit around the earth, the sun, or some other heavenly body" or "a small planet revolving around a larger one; moon."

Most man-made satellites are placed in orbits fairly near the earth, but some satellites orbit the earth far out in space. When satellites are placed in orbit far from the earth they will stay in orbit for long periods of time.

Why will a satellite placed in a near-earth orbit, say less than 200 miles, not stay in orbit for many months?

**

You can answer this question yourself. Let's pretend that you want to throw a baseball into orbit. You probably realize that your chances of success aren't too great!! However, let's go ahead and try. You can go outside and actually try this if you wish, but let's go through the reasoning together first.

Incidentally, if you do go outside and try this experiment, be very careful to select a direction for your orbital launch attempt that does not include near-by damageable objects (such as windows).

If you throw the ball as high and as far as you can you don't have much chance of getting the ball into orbit even if you are very strong. Why not?

**

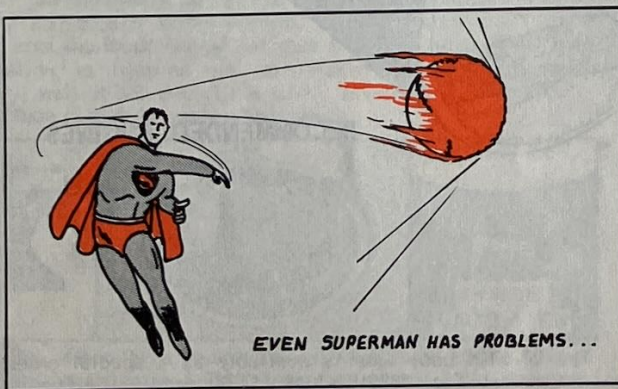

You could not throw the ball with enough force to overcome the pull of gravity. The ball was pulled toward the center of the earth by the force of gravity.

The First Law of Motion

This is an "action" article to help you to understand some principles of rocket flight. To get the most from your study follow these instructions:

Whenever an action appears, stop reading immediately and perform the action which has just been suggested. Keep thinking and try to reason out why the action was performed as well as what happened when the action was performed. Try to answer each question before going on with your reading

Could you tell that the ball was slowing down as it went upward? It was.

Try this experiment in some open place. Throw the ball as nearly vertically (straight up) as you can. Watch the ball as it goes up and comes down. If you have trouble seeing the ball well and concentrating on observing its motion, have a friend throw the ball vertically while you stand to one side and observe the ball.

**



The ball starts slowing down the instant it leaves your friend's hand. Your friend's effort caused the ball to move upward at a certain speed at the instant it leaves his hand. Thus the energy your friend gives to the ball caused the ball to have a certain momentum at the instant it leaves his hand. The momentum the ball possesses at this instant is measured by multiplying the ball's mass times the ball's velocity.

$$\text{MOMENTUM} = \text{MASS} \times \text{VELOCITY}$$

Mass has a special meaning, but here we can simply note that weight depends on mass, so the greater the mass of something, the more it will weigh on the surface of the earth.



The ball's mass doesn't change when your friend throws it up into the air, yet the ball soon slows down to a complete stop, then starts falling down to the ground. Can you observe any pattern to the speed with which the ball falls?

8

**

As the ball starts falling from the momentary pause at the top of its path, it falls faster and faster. This is caused by the force of gravity pulling it downward.

Your attempt to throw a ball into orbit around the earth didn't work. The moment the ball left your hand it had only so much energy in the form of momentum with which to go into orbit. The force of gravity was pulling this ball downward all of this time, but from the instant the ball left your hand you could not supply force to hold the ball up against the force of gravity.

The force of gravity pulled downward while the ball was moving upward. Result — the ball was slowed down.

Was the force of gravity the only force acting on the ball once it left your friend's hand?

* *

No. The ball moved through the air, and the air produced drag on the ball to slow it down. This drag is the resistance the air presents to the movement of the ball through the air.

You have felt this drag as you ran on a calm day and felt "the wind in your face." The faster an object is moving through the air, the greater is the aerodynamic ("moving air") drag on it.

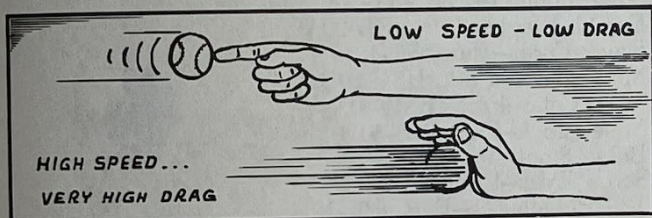

The force of gravity on the ball was the same regardless of the speed with which you threw the ball. The amount of drag encountered by the ball depended upon the speed of the ball. Both forces acted to reduce the ball's upward momentum. The force of gravity pulled the ball back to the earth.

The body in space around which another body revolves is called the *primary*. In this instance the planet Earth is the primary. The body revolving around the primary is the *satellite*. The path followed by the satellite is called the *orbit* of the satellite.

What forces exist on a satellite in orbit far above the earth?

**

The gravity of Earth is present, of course, although it is not very strong far from the Earth. The closer the satellite is to Earth, the stronger is the force of gravity acting on it. The force of gravity decreases *in inverse ratio* to the square of the distance between the centers of the two objects. In other words, the same satellite twice as far away (from the earth's center) would be attracted only 1/4 as strongly.

As we go farther from the surface of our planet, the atmosphere gets thinner. Yet there is a measurable amount of air even at an altitude of one thousand miles above the surface.

These two factors, the strength of Earth's gravitational field and the density of the atmosphere, cause satellites placed into low orbits to soon return to the surface while satellites placed in higher orbits stay in orbit for longer periods of time.

Newton's First Law of Motion states that "a body at rest will remain at rest and a body in motion will continue with constant speed in a straight line, *as long as no unbalanced force acts on it.*" This statement is often referred to as the Law of Inertia.

An unbalanced force is one which changes motion.

Inertia is the tendency of a body at rest to remain at rest unless pushed or pulled by an unbalanced force, and a body in motion continues to move in the same direction at the same speed unless acted upon by an unbalanced force.

This definition is not as complicated as it sounds. Many persons refer to two examples of inertia. One kind, called static inertia, is the inertia possessed by non-moving bodies. Can you think of an example of this?

**

A book sitting on a desk is one good example. As long as no unbalanced force acts on the book to move it, the book stays where it is. Can you think of a way to move the book?

**

Any force, applied to the book in great enough quantity, will cause the book to move. Picking up the book, pushing it along the desk with your finger, or hitting the book hard enough to knock it off the desk all qualify as forces great enough to move the book.

The inertia possessed by a moving body is sometimes called kinetic inertia. This is the tendency of a moving body to keep moving. We will consider kinetic inertia later.

Let's consider again a satellite in orbit far above the earth. The force of gravity, while weak, still pulls on the satellite. The satellite still encounters some aerodynamic drag from the few atoms, molecules, and ions of the atmosphere occurring this high above the surface. However, this aerodynamic drag force is very small.

The satellite may weigh very little if it is in a weak gravitational field. However, the satellite has the same mass when it is in orbit as it did when it was on the earth's surface.

The energy possessed by the satellite due to its momentum is equal to the product of the mass of the satellite times the velocity of the satellite. Due to its kinetic inertia the moving satellite tries to travel in a straight line.

Result — the satellite's kinetic inertia tries to keep this satellite moving in a straight line at a tangent away from its position in its orbit above the surface of Earth.

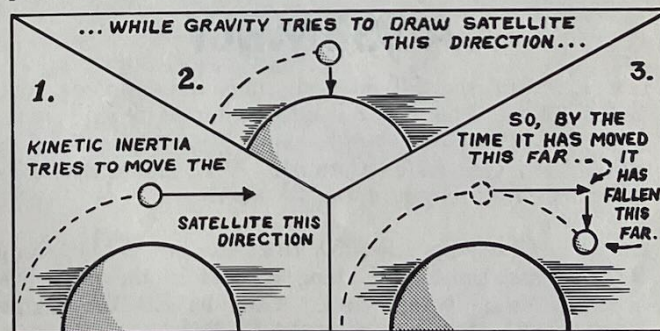

The force of gravity still attracts the satellite, so the satellite falls toward the earth.

Since both major forces acting on the satellite, momentum and gravity, are effective at the same time the actual motion of the satellite is affected by both forces.

Result—

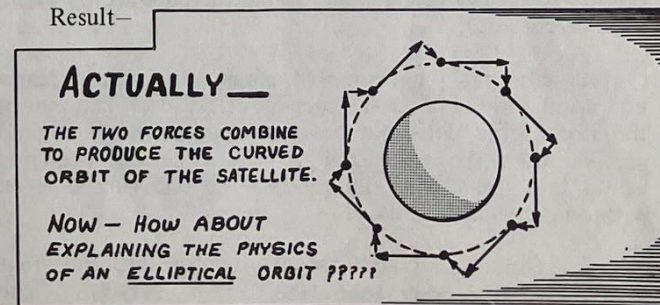

Conclusion: A satellite has to keep falling to stay in orbit!

Estes Industries Rocket Plan No. 57

Little Beth X-2

DESIGNED BY
Hal Kritzman

PUBLISHED AS A SERVICE TO ITS CUSTOMERS BY ESTES INDUSTRIES, INC., BOX 227, PENROSE, COLORADO 81240

© ESTES INDUSTRIES, 1968

ABOUT THIS 3-ENGINE BOOSTER PAYLOADER

The Little Beth X-2, August 1968 Design of the Month Contest winner, is an outstanding high altitude payload model designed by Hal Kritzman of Canton, Mass. Recommended for experienced rocketeers who have good cluster ignition systems, the Little Beth X-2 is an ideal booster for heavy payloads.

For best results, study Estes Industries Technical Reports TR-2 and TR-6 before launching your model. If you do not have copies of these reports, they can be ordered—check your catalog. With proper care the Little Beth X-2 will give amazing performance in flight after flight.

In test flights at Estes Industries this model was able to carry payloads of 2 and 3 ounces out of sight consistently. The model should always be flown with a payload of at least 1 ounce for best performance.

PARTS LIST

- 1 Body Tube--Part #BT-20M
- 1 Body Tube--Part #BT-20J
- 2 Body Tubes--Part #BT-20D
- 1 Body Tube--Part #BT-50
- 4 Adapter Rings--Part #AR-2050
- 1 Stage Coupler--Part #JT-50C
- 3 Engine Blocks--Part #EB-20A
- 2 Shock Cords--Part #SC-1
- 2 Nose Cones--Part #BNC-20B
- 1 Nose Cone--Part #BNC-50X
- 1 Nose Block--Part #NB-50
- 3 Balsa Stock--Part #BFS-40
- 3 Screw Eyes--Part #SE-2
- 2 12" Parachutes--Part #PK-12
- 1 18" Parachute --Part #PK-18
- 1 Launching Lug--Part #LL-2B

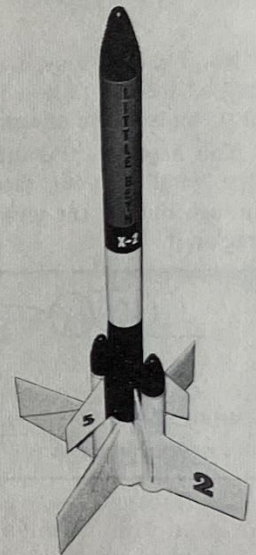

ASSEMBLY

1. Cut the BT-50 body into three pieces, one 2-3/4" long, one 8-1/2" long and one 6-3/4" long. Use the procedure shown under "Construction Information" in your Estes Catalog. Also cut the two BT-20D tubes to a length of 4-3/4" each.
2. Glue the AR-2050 rings to the 2-1/4" long BT-20M and the 2-3/4" long BT-20J in the positions shown in the overall view. Glue an EB-20A engine block into the forward end of the BT-20J.
3. Mark the 2-3/4" long piece and the 8-1/2" long piece of BT-50 for four fins on each. (See "Construction Tips" in your catalog.) Mark the two 4-3/4" long pieces of BT-20D with two lines directly opposite each other. (Use two of the "X" lines on the marking guide in your catalog.)
4. Glue the longer engine mount unit into the marked end of the 8-1/2" long section of BT-50. The end of the mount that does not have the engine block should project from the body 1/4". Glue the other engine mount into the 2-3/4" long BT-50 so one ring is even with one end of the tube.
5. Glue the JT-50C stage coupler into the front of the booster body tube (the 2-3/4" BT-50). The coupler should project 1/2" from the tube.

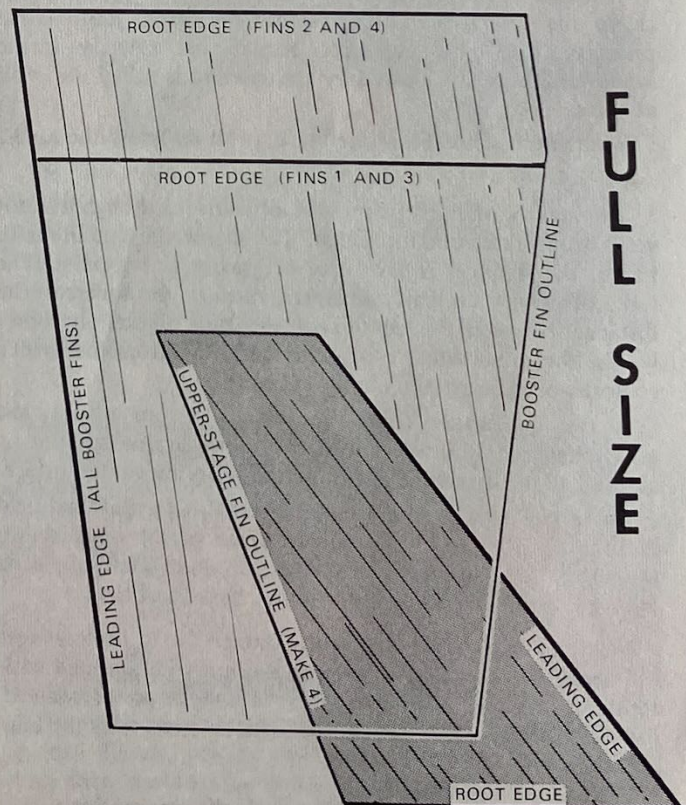

FULL SIZE

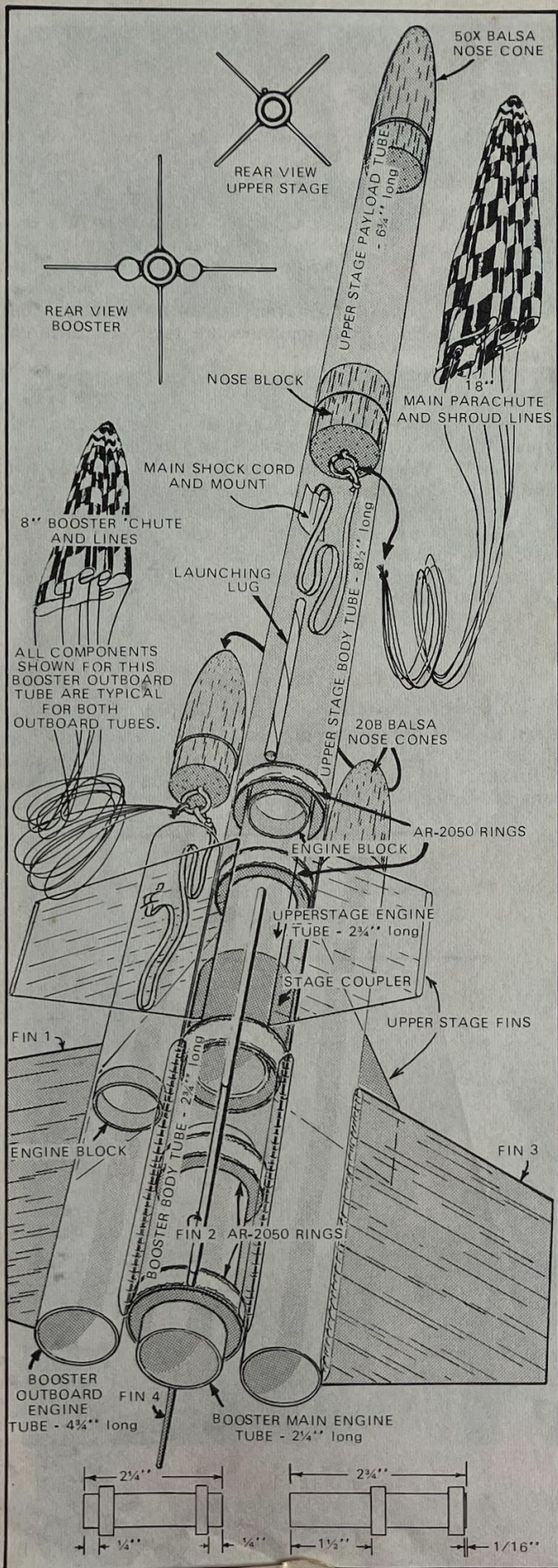

6. Glue the two 4-3/4" long pieces of BT-20D to the booster body tube. The ends of the side tubes should be even with the end of the engine mount tube. Check to be sure all three tubes are aligned perfectly, then set the unit aside to dry.

7. Mount an 18" long shock cord in the front of the 8-1/2" long upper stage body tube. Use the "Fold & Glue" anchor shown in the "Recovery Information" in your catalog.

8. Glue an engine block in each of the booster "side pod" tubes. The engine blocks should be 2-1/2" from the rear ends of the tubes. To do this, mark an expended engine casing 1/4" from one end. Smear glue around the inside of the tube, then push the engine block forward in the tube with the engine casing until the mark is even with the end of the tube.

9. Make 2 booster fins to each pattern and 4 upper stage fins. Make sure the grain of the balsa is parallel to the fins' leading edges. Sand the fins until smooth, then glue them in place. The smaller pair of booster fins should be attached to the BT-20 tubes and the larger booster fins to the BT-50 tube.

10. Mount a nine inch length of SC-1 shock cord in the front of each booster side pod tube. Use the slit system shown in "Recovery Information" in your catalog.

11. Cut out two 12" plastic parachutes, then trim them down to 8" diameter. Attach six 8" shroud lines to each parachute. Assemble an 18" parachute for the upper stage.

12. Glue an NB-50 nose block into one end of the 6-3/4" long BT-50 payload section tube. One half of the block should project from the tube. Glue a screw eye into the end of the nose block. Glue screw eyes into the ends of both BNC-20B nose cones.

13. Glue an LL-2B launching lug to the upper stage body tube in the position shown in the overall view. Apply a fillet of glue to each fin-body joint and support the units horizontally as the glue dries.

14. After the glue is dry connect an 8" chute and a BT-20B nose cone to the shock cord on each booster pod. Connect the 18" chute and the payload section to the upper stage shock cord.

FLIGHT PREPARATION

In preparing the Little Beth X-2 for flight, tape the C6-0 and C6-5 (or C6-7) together as you would for any multi-stage model. After taping the B4-2's to fit tightly in the side pods, insert the taped pair of C's into the upper stage and, secure with a wrap of tape overlapping the engine and the engine holder tube. Slide the booster into place and secure it with another wrap of tape.

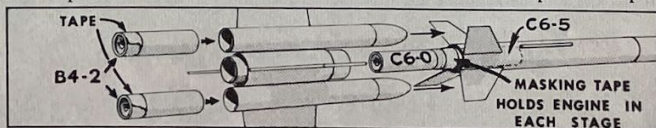

Only one combination of engines is recommended for this rocket—a C6-0 center booster, two B4-2 engines in the side pods, and a C6-5 or C6-7 in the upper stage. This combination will give the model a real ride.

ESTES SCIENCE FAIR

Contest Winners!

"....to support and encourage original research relating to model rocketry and to reward outstanding work involving model rocketry."

This is the Estes Science Fair Contest policy. The finalists in this year's contest showed much outstanding work by model rocketeers. In judging the contest the judges looked first to see if the project represented open-minded, objective, scientific research—and then looked to see if it used model rocketry effectively.

Each winner followed a logical method in his project. Each identified a problem, identified a procedure for finding an answer to the problem, conducted controlled experiments and evaluated the results of his experiments with an open mind, drawing a conclusion consistent with the observed facts.

FIRST . . .

The first-place winning entry was submitted by Carl S. Guernsey of Camp Hill, Pennsylvania. Carl, an 8th grade student, studied the effects of acceleration on algae. Using carefully measured samples, Carl launched the algae at different accelerations and then studied the results, both by microscope and by measuring growth over a period of time. Among other things, it was discovered that cells that appeared intact and undamaged under the microscope exhibited retarded growth after being launched.



SECOND . . .

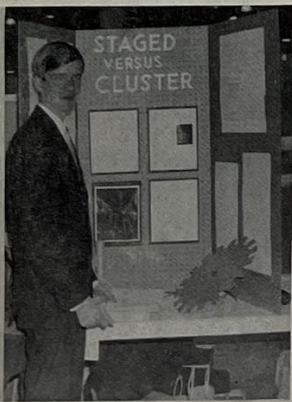

Second place went to Peter Wysgalla of Chicago, Illinois. Peter, in the 11th grade at St. Benedict High School, compared the performance of staged and clustered rockets. In carrying out his research, he was able to use a computer for performance calculations and then test these calculations with actual flights. The result was that he found neither system universally superior. Rather, he was able to formulate a set of guidelines

to show which system would be preferable under certain conditions.

DILSAVER WINS SEPTEMBER D.O.M.

Design of the Month Contest winner for September, 1968 is Michael Dilsaver of Glenview, Ill. Plans for the ZETA, Dilsaver's winning entry, are available without charge—check this issue's Clip 'n' Mail page or send your request direct to Estes Industries with a stamped, self-addressed envelope.

3rd.

The award for third place went to James Heitman, a 9th grade student at Martinsville High School, Martinsville, Indiana. James studied the "Krushnik Effect" (see MRN, Vol. 3, No. 1) to confirm its existence and to determine its extent and nature. Although he was not able to collect enough data to determine conclusively the nature of the effect, he was able to measure quite well the extent of thrust loss under various conditions. As a result he could draw conclusions as to the amount of thrust produced when engines are recessed different distances.

4th.

Fourth place went to Tancred Litterdale, a 9th grader from Dalton, Georgia who also studied the Krushnik effect. Although, due to too few tests, he was not able to plot the extent of the effect, he was able to prove that thrust is actually reduced and that the depth the engine is recessed determines the amount of thrust lost. The data available pointed to the probability that the loss of thrust is proportional to the distance the engine is recessed.

Honorable Mention

In addition, special Honorable Mention awards were given to Kent Randall of Houston, Texas; Dan Friedman of Colorado Springs, Colorado; Steve Kovar of Omaha, Nebraska; Jeff Andrews of Temple, Texas and Calvin Jahn of Garden City, New York.

The world stands aside to let anyone pass who knows where he is going.



G. Harry Stine and Dr. Willy Ley watch as Apollo Astronaut William Anders launches his first model rocket at the sixth NAR annual meet at Wallops Island, Va. Astronaut Anders is scheduled to fly on the Apollo 8 mission in late December or early January.