

# MODEL ROCKETRY

47755  
JULY 1971  
75¢

THE JOURNAL OF MINIATURE ASTRONAUTICS

## Report From The East Coast Boost/Glide Championships

Plastic Conversion:  
AMT SATURN V

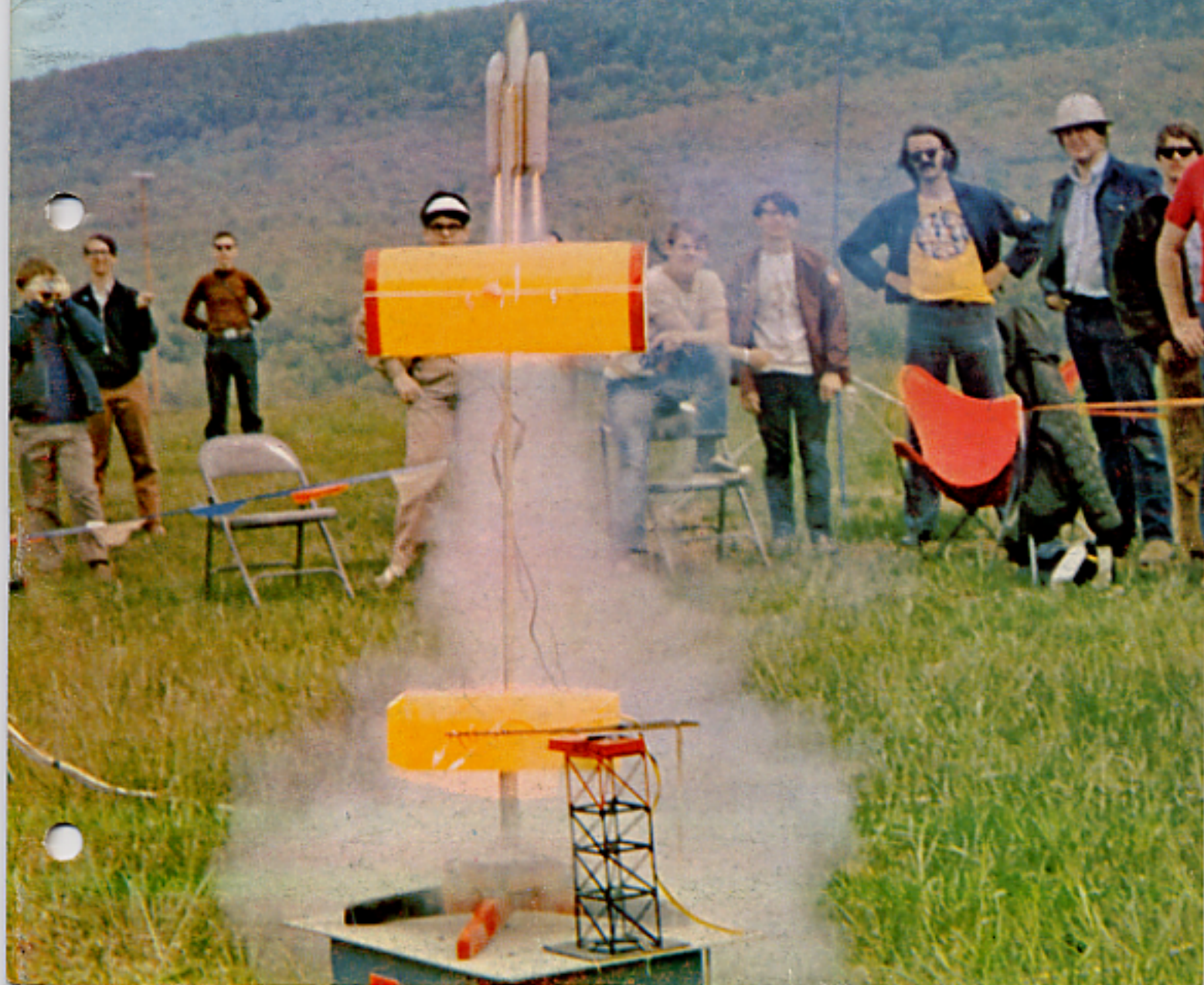

# **DESIGN & BUILD YOUR OWN HI-FLYING ROCKETS WITH**

**Centuri**

## **CUSTOM PARTS AND ACCESSORIES**



See your Centuri rocket dealer or write direct to Centuri Engineering Co., Dept. M71, Phoenix, Arizona 85017. Send your name and address and 25¢ (for the catalog) and we'll send you your Designer's Manual and catalog by return mail.

Get your free copy of Centuri's 32-page illustrated model rocket Designer's Manual. Includes step-by-step instruction on how to design and build model rockets. Learn how to select the proper engine for the model you build. Learn all the techniques the pros use. Includes design and parts list for four model rockets. Also, get Centuri's new 1971 catalog for a complete list. One hundred pages of engines, parts, supplies, kits and accessories.

**Centuri**

Dept. M-71 / 3053 West Fairmont / Phoenix, Arizona 85017

# Model Rocketry

Volume III, No. 9  
July 1971

Editor and Publisher George J. Flynn  
 Managing Editor Gordon K. Mandell  
 Technical Editor Douglas Malewicki  
 Assistant Editor Robert B. Singer  
 Assistant Editor Robert Parks  
 Business Manager Thomas T. Milkie  
 Distribution Manager Steven Glines  
 Technical Correspondent George J. Caporaso

## Cover Photo

This month's cover shows the liftoff of Randy Black's Condor Boost/Glider at the NART-2 competition. For more coverage of Condors, and boost/gliders of all other categories, see page 10 for a report on the East Coast Boost/Glide Championships.

(Cover Photo by George Flynn.)

## From the Editor

Two years ago, in the July 1969 *From the Editor*, I commented: "In recent months we have seen a great number of articles on the theoretical aspects of model rocketry. Important problems such as dynamics, altitude performance, stability, and drag have been analyzed. One aspect, however, of the scientific method has been largely absent from these treatments — *experimental verification of the theory*. Today, two years later, this situation still persists. Reading through the technical reports presented at this year's MIT Convention, few of the reports give evidence of experimental data to back up the suppositions or theories. Those which did present some experimental data were neither complete nor well enough controlled to "prove" the conclusions offered.

Any scientific theory remains in the realm of pure speculation until it is tested by experiment. The predictions resulting from analytical derivations must be compared with experimental data before their validity can be evaluated. In most fields of scientific inquiry there are two groups: the theoreticians and the experimentalists. The theorist will arrive at a description of some physical phenomenon based on a combination of intuitive hunches, generally accepted physical relationships, and previously known data. He will then report his *predictions* of the behavior of the system under study, whereupon an experimentalist will devise a method to *measure* the quantities of interest. He will compare his data to the theoretical predictions and, depending on the degree of agreement between experiment and theory, will accept or reject the theory. On the basis of this new data a more accurate theory may be proposed, once again to be checked by experimentation. By this process the theoretical description (and our understanding of the physical process) is made more accurate.

(Continued on page 46)

**The East Coast Boost Glide Championships** 10  
 Complete coverage of the first Record Trials devoted exclusively to boost/glide events. Everything from Hornet to Condor was flown — with varying degrees of success.

by George Flynn

**Plastic Conversion: AMT's Saturn V** 14

A plastic Saturn conversion easy enough for beginners but impressive enough for advanced rocketeers.

by John Frankosky

**Drag Reduction by "Boat-tailing"** 18

Part one of a technical report examining the benefits of "boat-tailing" on high performance models.

by George Pantalos

**Build the 'Sky Surfer II' Boost/Glider** 23

Complete plans for a competition Sparrow boost/glider which uses the pre-airfoiled styrofoam wings which are gaining in popularity.

Designed by Joe Niedenberger

**The Old Rocketeer: Engines Full Circle** 27

A report on the history of engine development from the first Carlisle Rock-A-Chute engines to the new MPC Minijets.

by G. Harry Stine

**Technical Report: Engine Thrust-Time Curves** 30

Simple analytical representations of Series I and II engine Thrust-Time curves, in a format suited for computer applications.

by S. W. Bowen

**The MIT Technical Model Rocket Convention** 31

On the scene report from the 1971 MIT Convention, complete with abstracts of all the R&D reports presented.

by George Flynn

**Fly the "Enayar"** 36

A high-performance model designed for the new 1/2A PD event.

by Steve Fentress

**Club Corner: Demonstration Launches** 38

The how's and why's of running a successful demonstration launch.

by Bob Mullane

## Regular Features

Letters to the Editor	2	New Product Notes	29
From the Launching Pad	6	News Notes	34
Modroc Calendar	9	Club Spotlight	47
Reader Design	22	Club Notes	48

**The Model Rocketeer (National Association of Rocketry)** 40

**Update Canada** 20

Worldwide newsstand distribution by Kable News Company, 777 Third Ave., New York NY 10027. Hobby shop distribution by Kalmbach Publishing Co., 1027 North Seventh Street, Milwaukee, Wisconsin 53233.

Second class postage paid at Boston, MA and at additional mailing offices. Model Rocketry magazine is published monthly by Model Rocketry, Inc., 639 Mass. Ave., Cambridge, MA 02139.

Subscription Rates: US and Canada \$7.00 per year \$4.00 for six months, 75 cents for single copy; Foreign \$13.00 per year, \$7.00 for 6 months, \$1.00 for single copy. For change of address please notify Subscription Department, Model Rocketry, Box 214, Astor Street Station, Boston, MA 02123 at least six weeks in advance. Include former address of mailing label with the new address.

Material submitted for publication should be accompanied by a self-addressed, stamped envelope if return is desired. Model Rocketry can assume no responsibility for material lost or damaged, however care will be exercised in handling. Articles accepted for publication will be paid at the rates current at the time of publication. Letters, contest information, news, announcements, ect. are assumed to be submitted gratis.

Undeliverable copies, notices of change of address, subscriptions, and material submitted to Model Rocketry, Box 214, Astor Street Station, Boston, MA 02123.

Printed in USA

©Copyright 1971 by Model Rocketry, Inc.



## NEW PLASTIC WELD CEMENT

Really different, really better! Double your hobby fun with this new, different formula which welds Plastruct and other plastic materials. Fast. Sure. And really strong. Try it! At your hobby

dealer, or send 79c U.S. coin for 2-oz. bottle.

**PLASTRUCT, Inc.** Dept. MR  
1621 N. Indiana St., Los Angeles, Calif. 90063

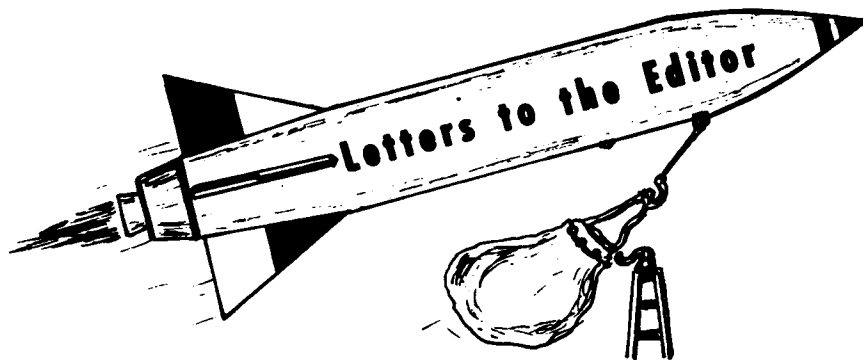

## ALL ABOUT SPACE!

SLIDES - PHOTOS - EMBLEMS - POSTERS

HF LP RECORD (Adventures in space from SPUTNICK 1 thru APOLLO 13) . . . \$3.95 plus 50¢ mailing and handling charges.

FLYING ROCKETS—MODEL KITS—SPACE TOYS by Estes, Vashon, Monogram, Lindberg, Mattel and more.

Send 50¢ for catalog to **SPACE PHOTOS**, Dept. MR3, 2608 Sunset Blvd., Houston, Texas 77005.

### From Overseas

Please enter my one year subscription to **Model Rocketry** magazine. I am currently stationed at Miyako Jima Air Station, Ryukyu Islands, and am the only active model rocketeer here as far as I know. I hope to experiment with telemetry here, since I have some sensitive communications receivers available. I have also brought over some Enerjet engines for high-speed and altitude work. Do you have the names of some telemetry device dealers I can write?

The PX does not stock your magazine and the hobby shop carries no model rocket supplies. Is there some way you could help to rectify this situation? I would greatly appreciate it.

Lt. Damian Houseman,  
APO San Francisco, CA

*Telemetry equipment is now available from several sources. Estes Industries has introduced the "Transroc" beacon transmitter and will have several sensor modules available soon. A complete catalog of "Transroc" sensors is available from Estes, Dept 31-M, Penrose, Colo. 81240. Kits for the "Foxmitter-2" telemetry transmitter, published in the June 1970 issue of Model Rocketry are available from Astro Communications, Dept. R, 3 Colridge Place, Pittsburgh, PA. A complete line of sensors is available from Astro Communications. An FM transmitter*

is available from **Lectronix**, Box 42, Madison Heights, Mich. 48071.

Your hobby shop can obtain copies of **Model Rocketry** from our distributor: **Kalmbach Publishing Co.**, 1027 North Seventh Street, Milwaukee, Wis. 53233. You might mention this to the shop owner.

### Balloon Recovery

At the moment we are working with a balloon recovery system. The balloon is to be inflated before, during, or after its flight in the rocket, and will serve as the recovery device. Anyone who has worked on this concept is requested to contact me at the address

Jack M. Aiello  
988 Jefferson S  
Monterey, California

### Parasite Glider Competition

While leafing through the March 1971 issue of MRm, I noticed an interesting idea suggested by Robert Kiefer of Belleville, Illinois concerning a "Parasite B/G" event. While the basic idea seems good, it might be advisable for reasons of safety to limit the number of gliders attached to the pod to two. Also, it seems to me, no engine under a "B" could be used, because such a contraction would not have a stable flight if under powered.

Other than the safety factor, which would have to be controlled, I can see no reason not to include "Parasite B/G" as an official contest event. I think that such an event

## HOBBY CATALOGS

FROM THE WORLD'S LEADING HOBBY HOUSE

AIRPLANES	.....\$1.50
RAILROAD	..... 1.75
SHIPS (Wood)	..... 1.00
MILITARY	..... 1.00
CRAFTS	..... 1.00
RACEWAY, SCIENCE & ROCKETRY	..... 1.00

Dealer Inquiries Invited  
314 FIFTH AVENUE  
N. Y., N. Y. 10001  
2072 FRONT STREET  
E. MEADOW, L. I., N. Y.  
197 Woodbridge Center  
Woodbridge, N. J.  
512 MILBURN AVENUE  
MILBURN, N. J.



## MAIL ORDER HEADQUARTERS

**DON'T BE LEFT OUT OF AMERICA'S NEWEST, MOST EXCITING HOBBY!**

MODEL ROCKETRY SUPPLIES ARE AS CLOSE AS YOUR MAIL BOX ----

**ESTES, CENTURI, MINI-MAX, FLIGHT-SYSTEMS, MPC, COX, AMROC, SAI, CMR, SEMROC, MITS, ENERJET, VASHON, COUNTDOWN.... SEND 50¢ AND WE'LL MAIL YOU OUR LATEST CATALOG**

**orange blossom hobbies, inc.**

1975 N.W. 36<sup>th</sup> STREET dept. MR  
MIAMI, FLORIDA 33142

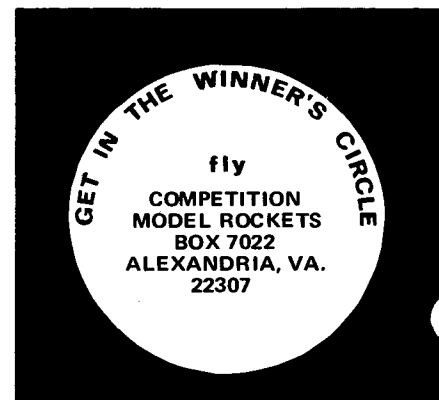
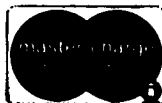

would draw a lot of original and ingenious designs by many half-crazed rocketeers, myself included, who would jump for joy at the thought of another new B/G event.

Buddy Smith  
Vice-President  
Hawkeye NAR Section  
Davenport, Iowa

### PD Converted Streak

I have finally succeeded in putting parachute recovery in the Astron Streak. This trick has occurred to me before, six years ago in fact, but I never made it work. Earlier tries include the present system first, then attempts with a series III engine, but there was never enough room for wadding and parachute both.

### Micro-Hi

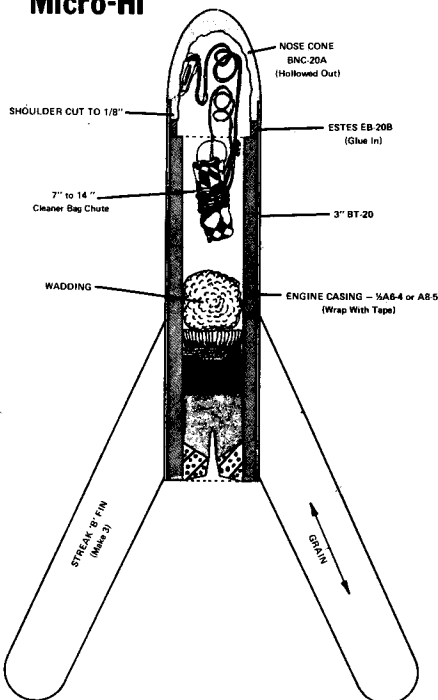

The trick is to use the surplus space inside the smaller engines (an A8-5 doesn't use a third of the casing.) With A8 and B6 engines, the inside casing is almost half an

inch in diameter and provides enough space that way. With 1/2A and 1/4A, so much space is left that there is no problem at all including a chute.

The Estes Streak is modified as follows, the nose cone is hollowed out and the shoulder cut to 1/8". The shock cord is 14" of finishing line with a rubber band tied to two points along as a bungee, and mounted to the inside of the nose cone by a three-panel shock cord mount cut from bond paper -- but much smaller than usual. The body tube is replaced with 3" of BT-20, and an Estes EB-20B (1/8") engine block is mounted just far enough in the front end to make room for the nose cone shoulder. As the engine block is inserted, the shock cord is crimped under it. The parachute, mounted to the nose cone the same way as the shock cord, is made from a cleaner bag, with eight sewing thread shroud lines attached with small squares cut from a Band-Aid. A 14" chute will fit neatly if well packed.

Parachute Duration and Design Efficiency fans take note, with either a 1/2A6-4, A5-4, or A8-5, this bird is still climbing fast when the ejection charge fires. It's out of sight on the A8-5, which is great because that's really the largest practical engine. Duration with that engine was 114 seconds, almost two minutes. At liftoff mine was a shade over 22 grams, including more than 16 grams of engine.

Peter Clay  
Eugene, Oregon

### More Relativistic Rocketry

The article, *Relativistic Model Rocketry*, found on page 29 of the April 1969 edition (Vol. 1, No. 6) shows incredible insight and knowledge of the issues involved. Unfortunately, you overlooked a major part of space physics. The average modroc is a *Four* dimensional object, consisting of a space figure and its time coordinates. Therefore, when a modroc reaches its top speed it will be the *time* dimension that will suffer a lack, instead of the space dimensions. The fast-flying modroc will lose some of this allotted time of existence while in the air. Some birds don't have much time anyway, and, upon using it all up in the air, rapidly descend to the ground on which they self-destruct. This effect also explains the occur-

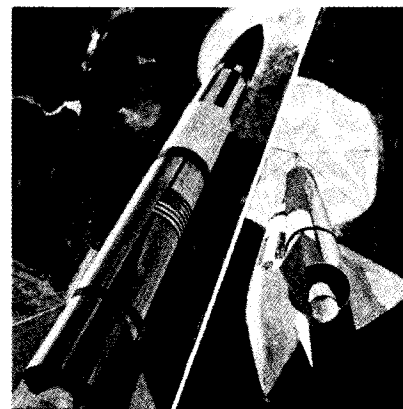

Shoot for more fun in '71 with "Valkyrie," the model rocket that's ready to go — complete with launcher and fuel. It's all there, nothing else to buy! Fun and easy to assemble, flights up to 1,000 feet, with parachute recovery. Safe, cool rocket fuel. Shipped postpaid \$15.95, or send 25c for catalog. (Included free with order).

# VALKYRIE

# Q29

VASHON INDUSTRIES INC.

Dept. 161, Box 309,  
Vashon, Washington 98070

## Aluminized Mylar Streamers

6 feet long—Excellent tracking

One side aluminized, other side choice of red, green, blue. Tape strip included.

3 for \$1.35 (plus 15¢ handling)  
Immediate Delivery!

RECOVERY SYSTEMS  
471 Philadelphia Ave.  
Massapequa Park, N.Y. 11762

### ROCKETS!

2000 feet plus with single and multi-stage kits. Tubes, nose cones, engines, parachutes. The new SAI Hen Grenade kit available for \$2.50 plus 35¢ postage. Amazing accelerometer kit, only \$2.00. Scale models, sport models, competition models! Same day service. Catalog \$2.25. ROCKET SUPPLY CO., Dept. MR, River Edge, New Jersey 07661.

# HEN GRENADE



SPACE AGE INDUSTRIES

Only  
**\$2.50**

CANADIAN DISTRIBUTOR:  
Space Age Industries of Canada  
P.O. Box 88, Youngstown, Alberta

*Now At Your Local Hobby Shop!*

## Lercari Engineering

P.O. BOX 90894

WORLD WAY CENTER

LOS ANGELES, CALIF. 90009

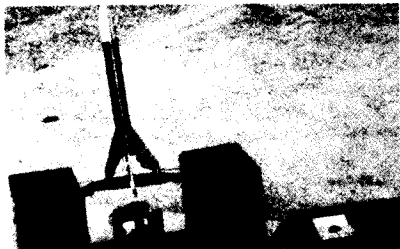

### REMOTE CONTROL LAUNCHER

- COMPLETE LAUNCH CONTROL FROM PANEL
- TWO MOTOR DRIVEN LAUNCH ANGLES
- ACCURATE LAUNCH ANGLE METER ON PANEL
- ELEVATION LAUNCH ANGLE: +45° TO -30°
- AZIMUTH LAUNCH ANGLE: +80° TO -80°
- 25 FOOT COMMUNICATION CABLE

Send 25¢ for Brochure



P.O. BOX 424  
WILLOUGHBY, OHIO 44094  
DEPT. MR

SPACE & ROCKET MODEL KITS

We carry MPC, SPACE AGE IND., REVELL,  
AURORA, LINDBERG, HAWK, VASHON IND.,  
AMT, L.M. COX — 35¢ for Catalog &  
FREE Color Print of THE APOLLO 11 LIF-OFF  
— Complete Mail Order Service —

### MOON LANDING PICTURES . . .

35 mm Apollo slides, Astronaut emblem patches, moon maps, books on space, rocket models, other gifts and souvenirs from Cape Kennedy. Write for FREE BROCHURE today!

ASTROLAND — BOX 234-R  
MERRITT ISLAND, FLORIDA 32952



### OUTER-SPACE MAP

Study the solar system with a Giant 42"x33", 8-color space map shows our entire solar system and each planet's orbit, size and distance relationship to the sun and earth. Only \$1.00 Postpaid. Chespa Sales, P.O. Box 117, Barrington, N. J. 08007

US, USSR

Slides, Prints

### ROCKET PHOTOS

Write for our complete list of color and black and white rocket photos. These slides and prints are carefully selected for use as scale substantiation data. Send \$1.00 for your choice of a Mercury-Redstone 7, USSR Vostok, or Saturn V liftoff color transparency and complete photo list. (For the list only, send 25¢ and a stamped, self-addressed envelope.)

Rocket Equipment Co.  
Dept. A, 10 Mulberry Ave.  
Garden City, N.Y. 11530

ence mentioned in paragraph four under case one. It can explain why Quadrathon and B/G birds (having little time to begin with) can dilate 10 minutes of life into a few seconds and prang promptly.

The most exciting effect caused by this time dilation is the complete removal from the time dimension of the rocket. This is an effect observed in altitude modrocs, egglofters, and other high power, high speed vehicles. In order for a modroc to do this it must be still accelerating when it runs out of time in the air. The singularity thusly produced allows the modroc to slip through into a purely 3-D limbo.

All rockets slow down, even pure 3-D ones. Upon slowing, the vehicle reenters the standard 4-D world at *exactly the same place that it left it*. However, it may not be the same *time* that it left. A singularity, having no dimensions, can travel through all of time but still occupying the same space coordinates. The rocket could return in 1972, 2971, or 1971 B.C. This explains the disappearance of many a vehicle.

The reader may wonder where I, the author, got all of this information. This article was based on the results of many experiments which I undertook between Mar. 23rd and April First.

Jonathan Vaughan  
Jacksonville, Fla.

*Copies of the original article Relativistic Model Rocketry, April 1969 MRm, are still available in limited quantities from our back issues dept., MRm, Box 214, Astor Sta., Boston, MA 02123, for 75¢ each.*

### Luna Glo Paints

Thank you for your mention of our Luna Glo fluorescent paint products in your April issue. I would, however, like to call one error to your attention. Our Luna Glo fluorescent spray paints are retailed at \$1.89, not \$2.98, and are available in seven fluorescent colors--red, blue, green, yellow, purple, orange, and pink.

Edgar G. Lowrance  
IMS Corporation  
3415 Vassar Drive, N.E.  
Albuquerque, New Mexico

### FREE!!!

1/144 scale AMT

Saturn V

Plastic Kit

with purchase of

Blinky Flasher

with Payload Capsule

A complete Electronic Light Flasher kit designed for model rocket use. Includes plastic nose cone, battery compartment, and transistorized "BLINKY" kit.

only \$4.50 postpaid

Lectronix

P.O. Box 42

Madison Heights, Mich. 48071

## ARE YOU MOVING?

Every day we get a handful of address labels back from the post office with either a change of address on them or a note that the subscriber has moved and left no address. The magazines are thrown out and just the address label is returned.

Please don't expect us to send you another copy if you forget to notify us in advance of an address change. Remember, it takes about 6 weeks to process an address change, so send us notification of your address change at least 6 weeks in advance.

Send address changes to Change of Address, Model Rocketry, Box 214, Astor Street Station, Boston, MA 02123. Please include the address label from the last Model Rocketry you received.

NAR members receiving Model Rocketry as part of your membership benefits should send change of address notices direct to NAR Headquarters, not to the above address.

# P D

1/4 MIL

## ALUMINIZED MYLAR CHUTE MATERIAL

For duration competitions use the lightest, thinnest chute material available. This 1/4 mil mylar is aluminized on one side for easy visibility. You can fit a 36 inch chute in an 18 mm standard tube. One 56 inch by 10 foot sheet is enough for two 56 inch diameter competition chutes, or three 36 inch chutes. Order today!

Only \$5.00 per sheet

Rocket Equipment Company  
Dept. RS  
10 Mulberry Ave.  
Garden City, New York 11530

# Be nice to your scratch-built rocket.

You've invested a lot of time and energy in your beautiful bird, not to mention some pretty tedious



Cox Solid Fuel Engine  
and Cox Safety Igniter.

work. If you want it to perform to match your craftsmanship, you won't try to fly it with second-rate engines and accessories. You'll use the best: the Cox family of model rocketry components. See them

and our line of fine, beautifully detailed, ready-to-launch model rockets at your favorite store.

**Premium Fuel:** It may be rated in newton-seconds instead of octanes, but it's still the best. Why? Because Cox Solid Fuel Engines provide a better power-to-weight ratio in the standard .69" x 2.75" casing than any other manufacturer's. Which means that you get more usable power out of a lighter package. And this year, Cox is introducing the most potent member of the line: the D8. The D8 produces 50% more power than was previously available in standard .69" x 2.75" casing. All Cox engines feature dense, highly visible tracking smoke.

**Positive Ignition:** Cox Safety Igniters\* provide fail-safe arming because the igniter is plugged into the electrical circuit prior to insertion into the engine. No "micro clips" or groping around the base of an armed rocket required.

**For a Winning Start:** The precision engineered Cox Model Rocket Launch System has adjustable legs, remote launch controller with safety key, "systems go" check light, and a safe 20 feet of

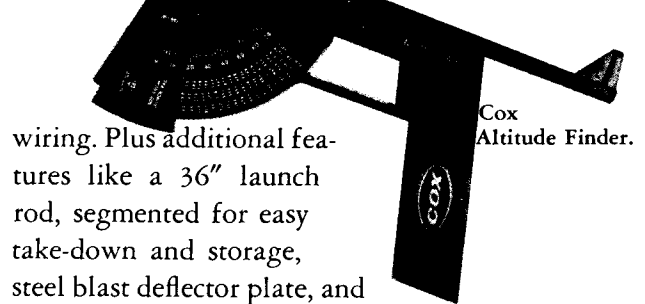

wiring. Plus additional features like a 36" launch rod, segmented for easy take-down and storage, steel blast deflector plate, and the launch base holds 8 "D" cells (not included) for dependable single engine ignition time after time.

## High Performance Requires

**Fast Tracking:** Cox's ready-to-use Altitude Finder is a quick, easy way to pinpoint the angle and height of your rocket's apogee. As the rocket reaches maximum height, the Altitude Finder's trigger is released, locking the direct readout gauge in position. The rocket's altitude is read directly in feet with no immediate calculations or trigonometry tables required.

**Power Brakes:** Cox Parachutes come pre-cut with shroud lines and snap-swivels attached. An elastic shock cord is included to guarantee that your favorite bird won't do a pancake landing from 800 meters. In 12", 16" and 20" diameters.

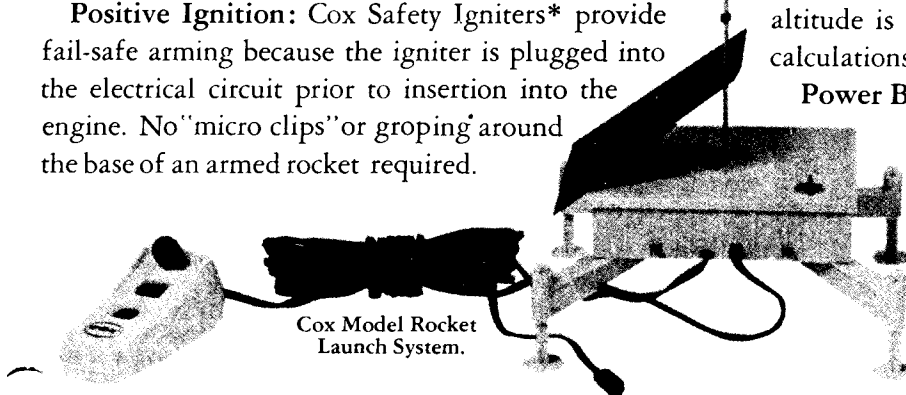

Cox Model Rocket  
Launch System.

L. M. COX MFG. CO., INC., a subsidiary of LEISURE DYNAMICS, INC.  
1505 East Warner Ave., Dept. MR-7 Santa Ana, California 92705



\*pat. pend.

## SOLICITATION OF MATERIAL

In order to broaden and diversify its coverage of the hobby, MODEL ROCKETRY is soliciting written material from the qualified modeling public. Articles of a technical nature, research reports, articles on constructing and flying sport and competition models, scale projects, and material relating to full-scale spaceflight will be considered for publication under the following terms:

1. Authors will be paid for material accepted for publication at the rate of two dollars (\$2.00) per column inch, based on a column of eight-point type thirteen picas wide, for text, six dollars fifty cents (\$6.50) for drawings, and two dollars (\$2.00) for photographs accompanying text. Payment will be made at the time of publication.

2. Material submitted must be typewritten, double-spaced, on 8½ by 11 inch paper with reasonable margins. Drawings must be done in India ink and must be neat and legible. We cannot assume responsibility for material lost or damaged in processing; however our staff will exercise care in the handling of all submitted material. An author may have his manuscript returned after use by including a stamped, self-addressed envelope with his material.

3. Our staff reserves the right to edit material in order to improve grammar and composition. Payment for material will be based on the edited copy as it appears in print. Authors will be given full credit for published material. MODEL ROCKETRY will hold copyright on all material accepted for publication.

Those wishing to submit material should send it to:

Editor,  
Model Rocketry Magazine,  
Box 214,  
Boston, Mass. 02123

NATIONAL  
AEROSPACE  
EDUCATION  
COUNCIL

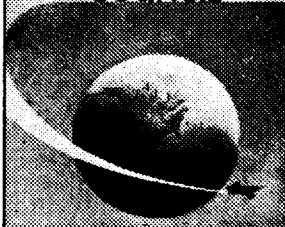

806 - 15th St. NW  
Washington, D. C. 20005

FOR  
MEMBER-  
SHIP  
INFO  
WRITE  
NOW

## FROM THE

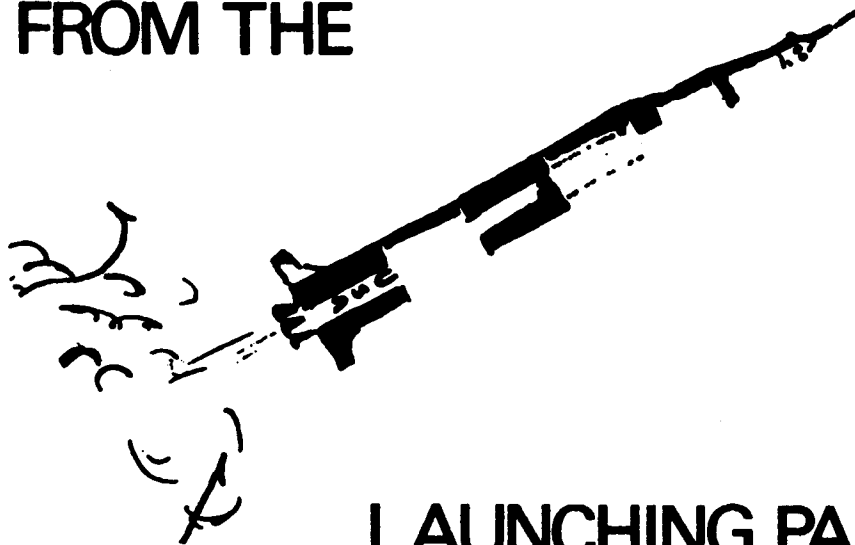

## LAUNCHING PAD

We had hoped to have a photo of the East Coast Boost/Glide Championships on the cover this month, however the bad weather at ECBGG prohibited the use of color film. Three sunny and bright weeks separated the B/G Championships from NART-2, 100 miles further west in Pennsylvania. But for NART the rains returned, and it looked like color photos of this meet would also be impossible. However, the cloud layer thinned a little during the Condor flying, and we managed to get a few quick shots of the colorful Condors. Next month's Model Rocketry will contain complete coverage of NART-2.

Doug Plummer has "expanded" on his ZNT design published in the April/May 1971 issue of Model Rocketry. The ZNT, as you will recall, used twelve small tubes rather than fins for stabilization. The new design, the Super-ZNT uses more stabilizing tubes than we could count. There are five rows of "hoops," each containing six tubes, plus a few more glued on for good measure.



Doug Plummer preps his new Super ZNT, an "uprated" version of the ZNT which was published in the April/May MRm.

The Super-ZNT made a good, stable demonstration flight at ECRM-5. These "odd-ball designs" are getting odder and odder every day.

While on a visit to Long Island in mid-May, I came across an interesting missile kit on the shelves of Polk's Hobby Store in East Meadow, New York. The kit, which has apparently been available for over a year but is seen on few store shelves, is the UPC "Honest John." This is a 1/40 scale model of the U.S. Army Honest John on the standard truck launcher. Thus far, I haven't completely assembled the kit, but the detailing on the launcher looks quite good. With the new MPC "Minijets," it should be possible to flight convert this model and fly it off the scale launcher. It looks real good, and if the flight conversion works out you can expect to see this one in Model Rocketry later this summer.

In evaluating the Research and Development entries at this year's MIT Convention the judging team—Len Feshkins, Gordon Mandell, and Jay Apt—established a set of seven criteria to be used in selecting the winners. These guidelines may prove valuable to other groups who plan on judging R&D in the future as well as to rocketeers who are preparing R&D reports. Their criteria for rating the projects were as follows:

- 1) The innovativeness of the concept investigated,
- 2) The *theoretical* contribution to the state-of-the-art,
- 3) The *practical* contribution to the state-of-the-art,
- 4) The explicitness and validity of the assumptions made,
- 5) The method of organization of the experiments (use of the proper analytical method),
- 6) The validity of the conclusions in light of the data presented,
- 7) The quality of the written and oral reports.

To further promote the purposes of R&D, summaries of all reports were submitted, printed, and distributed (at cost) to convention participants. All it takes is a mimeo machine, and rocketeers throughout the coun-



# Edison Rocket Center

DEPT. MR, 238 PLAINFIELD AVENUE, EDISON, NEW JERSEY 08817

ALL ADVERTISED ITEMS ARE IN STOCK - MAIL ORDER SPECIALISTS - QUICK MAIL SERVICE

BODY TUBES				
Size	ID(in.)	OD (in.)	Wall Th.(in.)	Price
<b>ESTES</b>				
BT-5	.515	.541	.013	.30
BT-10	.710	.720	.005	.30
BT-20	.710	.736	.013	.30
BT-30	.725	.765	.021	.30
BT-50	.950	.976	.013	.40
BT-55	1.283	1.325	.013	.60
BT-60	1.595	1.637	.021	.65
BT-70	2.175	2.217	.021	.85
BT-101	3.895	3.938	.021	1.75
<b>CENTURI</b>				
ST-518	.515	.543	.014	.30
ST-718	.715	.759	.044	.30
ST-818	.865	.908	.043	.35
ST-1018	1.000	1.040	.040	.40
ST-1318	1.300	1.340	.040	.60
ST-1618	1.600	1.640	.040	.65
ST-2018	2.000	2.040	.040	.85
<b>SAI</b>				
T-19	.716	.748	.016	.30
T-20	.747	.787	.020	.30
T-22	.864	.890	.013	.35
T-23	.894	.920	.013	.40
T-28	1.032	1.102	.035	.40
T-30	1.149	1.181	.016	.45
T-30B	1.121	1.181	.030	.60
T-45	1.732	1.772	.020	.60

(All body tubes are in 18" lengths.)

### Mail Order Specials

- 4 Photo Flash Batteries (Regular price .39 each) **only \$1.00**
  - 100 ft No. 32 Nichrome Wire (Regular price 2.85) **only \$1.50**
- (Only available on orders of \$5.00 or more.)

Most parts, nose cones, adapters, fins, etc. from MPC, Estes, SAI Centuri, CMR, etc. are available. Order by part number.

MPC				
F-1 Moongo	2.00	K-42	Orbital Transport	3.25
R-842 Redstone Quasar	2.00	K-44	Birdie	.60
R-843 Pegasus MK-II	2.25	K-45	Beta	1.50
R-844 Martian Patrol	3.00	K-46	Shrike	4.75
R-845 Aquarius	2.00	K-47	Cherokee-D	2.75
9000 Vostok RD-107	4.00	K-49	Sprint	1.75
9002 Titan III	4.00	K-52	Omega	3.50
R-846 Nike Smoke	1.00	K-29	Saturn 1B	10.95
R-847 Star Hawk	1.00	K-36	Saturn V	13.50
R-848 Tomahawk	2.00	K-43	Mars Lander	6.00
R-849 Nike Patriot	3.00	K-48	Bandit	3.75
R-300 Yankee I (Assembled)	4.00	K-57	Skydart	3.25
		K-58	A-20 Demon	3.95
		K-2A	Mark II	1.35

Most catalog item available, order by part number.

Estes				
K-1 Astron Scout	.70			
K-2 Astron Mark	1.25			
K-3 Astron Space Plane	1.80			
K-4 Astron Streak	.70			
K-5 Astron Apogee II	2.00			
K-6 Astron Ranger	3.00			
K-7 Astron Phantom	1.75			
K-8 Astron Sky Hook	1.35			
K-9 Astron Space Man	.75			
K-10 Astron Cobra	3.00			
K-11 Wac Corporal	1.50			
K-12 Astron Farside	2.75			
K-13 Astron Falcon	1.00			
K-14 Astron Drifter	1.75			
K-15 Astron Sprite	1.00			
K-16 Astron Delta	2.25			
K-17 Aerobee 300	2.00			
K-18 Astron X-Ray	1.75			
K-20 Mars Snooper	3.25			
K-21 Gemini Titan GT-3	5.25			
K-22 V-2	2.00			
K-23 Big Bertha	3.00			
K-24 Astron Gyro	1.25			
K-25 Astron Alpha	1.50			
K-26 Arcas	2.25			
K-27 Honest John	2.00			
K-28 Thor Agena-B	3.25			
K-30 Little Joe II	3.25			
K-31 Star Blazer	1.25			
K-32 Astron Starlight	2.35			
K-33 Astron Trident	4.00			
K-34 Astron Nighthawk	2.00			
K-35 Astron Constellation	2.00			
K-36 Astron Scrambler	4.25			
K-37 Astron Avenger	3.25			
K-38 Saturn V Semi-Scale	3.50			
K-40 Astron Midget	1.25			
K-41 Mercury Redstone	3.50			

KS-10 Saturn IB	9.95	Fiberglass Recovery Wadding (6 by 6 by 1")	.35
KS-12 Saturn V	16.95	LBP Shock Sponge (4 1/2 by 5 by 3/8")	3 for .25
KS-15 Nike Smoke	3.50	ALT-1 Sky Track Single	24.50
<b>Silk Parachutes</b>			
PS-12 12 Inch	1.90	Payload Weight 1 Oz.	.50
PS-18 18 Inch	2.75	Adjust-A-Roc	6 for .25
PS-24 24 Inch	3.50	Experimental designer's Kit for Advanced Model Rocketeers- \$16.00 Value-	
PS-30 30 Inch	4.50	Cox	
PS-40 40 Inch	7.50	5025 Apollo Saturn 1B	8.00

Model Rocket Contest Products			
1/4 mil. Plastic Parachutes			
24 inch	.35		
30 inch	.45		
36 inch	.55		
1/4 mil. Aluminized Mylar Parachutes			
20 inch	.70		
30 inch	1.25		
36 inch	1.50		
<b>MPC</b>			
R-204 Lambda Payload	1.50	<b>Engines</b>	
R-205 Icarus C	1.50	Estes: A,B,C,D's	
R-207 Theta-Cajun	2.00	Centuri: Enerjet E&F's	
R-209 Microsonde III	3.00	MPC: A,B, & C's	
R-211 Zenith II Payloader	3.00	FSI: A,B,C,D,E, & F's	
R-212 Flare Patriot	2.00	SAI: A,B,C, & D's	
R-215 Lunar Patrol	3.00	(All at Manuf. Prices)	
R-216 Flat Cat	2.50		
R-810 Pioneer I	1.00		
R-822 Redstone Maverick	1.50		
R-823 Viper	1.70		

<b>Books</b>			
Hand Book of Model Rocketry	6.95		
Model Rocketry Manual	1.50		
<b>Glue</b>			
Hobbyoxy Formula 1 Cures	1.00		
Hobbyoxy Formula 2 Cures	3.00		
Hobbyoxy Formula 4 Cures	2.00		
Testers Wood Glue	.15		
Ambroid	.25		
Ambroid	.39		
Elmers	.29		
Elmers	.59		
<b>Paints</b>			
Testors Dope 1 oz.	.25		
Testors Dope 4 oz.	.69		
Testors Dope			
Testors Thinner 1 oz.	.25		
Testors Thinner 4 oz.	.60		
Rubbing Compound	.85		
Finishing Wax	.85		
<b>Balsa</b>			
3/32 by 3 by 12"	3 for .60		
1/8 by 3 by 12"	3 for .70		
1/16 by 3 by 12"	3 for .55		
Fireproof streamers	.35		

Competition Model Rocket			
BG-1 Manta	2.50		
C-1 Brake-Away	2.50		
C-2 Hyper	2.95		
C-3 Eto (Egg Lifter)	4.25		
C-4 Effy	1.60		
C-5 Rapiar	1.95		
C-6 Marcus	1.00		
C-7 D Region Tomahawk	4.50		
BT-1 Tube Cutter	1.75		
34A Fin Guide	2.00		
<b>Bo-Mar</b>			
Alpha I	\$1.95		
Spartan	2.00		
Alpha B	1.95		
Swift	1.50		
Astro-Quest	2.00		
<b>Semroc</b>			
Sigma II	1.98		
Lune RI	2.98		
XK-23	1.98		
Apheleon	1.98		
Swift	1.49		

<b>Space Age Industries</b>			
K11 Judge	2.25		
K12 Nike-Deacon	3.00		
K13 Unicorn	1.75		
K15 Tempus Fugit	1.50		
K17 Mini-Bat	1.50		
K19 Pegasus	2.50		
K20 Falcon	4.50		
K21 Thunderbolt	.89		
K22 omega III	2.95		
K23 Wombat	1.25		
K25 Hen Grenade (Egg Lifter)	2.50		
K24 Pulsar	2.95		
K100 Scorpion	1.50		
K101 Hawk	2.95		
Blinkin Beacon (Tracking Light)	2.95		
Circuit Board and Instructions Only	1.00		
Accelerometer	2.00		
Axtra Accelerometer	1.00		
Scribe Paper	1.00		
Creare-A-Cal Decal Kit	2.00		
Big Bag of Balsa Blocks	1.00		
Apollo II Decal	.25		
American Flag Jacket Patch	1.00		

**Hawk B/G**  
by SAI



**FREE!!!**

Wing Span	10 inches
Length	11 inches
Diameter	7/8 inches
Weight	5 ounces

All orders over \$5.00 will receive a free Hawk kit.

# Subscribe today! MODEL ROCKETRY

If you're interested in....  
**ROCKET TRANSMITTERS**  
**ROCKET ELECTRONICS**  
**SCALE MODEL ROCKETS**  
**TECHNICAL ARTICLES**  
**ODD-BALL DESIGNS**  
**TRACKING SYSTEMS**  
**FINLESS ROCKETS**  
**PAYLOAD ROCKETS**  
**LAUNCH SYSTEMS**  
**CAMERA ROCKETS**  
**BOOST-GLIDERS**  
**RADIO-CONTROL**  
**COMPETITION**  
**CLUB NEWS**

Then keep abreast of  
 the latest developments....



Have MRM delivered  
 to your door!

<input type="checkbox"/> 1 Year, \$ 7.00	<b>MAIL TO:</b> Model Rocketry
<input type="checkbox"/> 2 Years, \$ 13.00	Box 214 B
Name _____	Boston, MA 02123
Street _____	
City _____ State _____ Zip _____	

DON'T MISS AN ISSUE

SUBSCRIBE TODAY!!!

try can have access to the research being done in the hobby. Other clubs planning R&D contests should consider similar publication of the reports submitted to them.

From time to time we get a letter from a skeptical rocketeer who asks whether the Model Rocketry staff actually flies the designs we publish. We fly many of them. In fact when a feature article is received we generally build a model here so that we can evaluate the flight performance.

When the plans for the Space Dart (April/May '71 MRM) were received, I liked the design so much that I had built one by the next morning. It was easy to trim, and the glide was excellent, so I decided to fly it in Hawk B/G at ECRM. Unfortunately, it boosted so well that it drifted out of sight within a minute (It's a very small glider for Hawk). No one even has a guess on the duration, since the windy weather caused a number of the good flying Hawks to fly away. The performance was impressive enough, however, that I built two more Space Dart's for the East Coast B/G Championships. They were flown in the Hornet, Sparrow, and Swift events there. (I never got around to the Hawk flight because of the high winds.) In the Hornet event the Space Dart was a total flop - it is a little bit too heavy for 1/2A power.

Sparrow and Swift were a different story! The Space Dart took first in D Division Sparrow with 42.5 seconds, even though it "Red Barroned" part of the way down. In Swift the Space Dart ran into the same problem it had encountered at ECRM - wind. Though it took first place in Swift with 78.0 seconds, that was the time until it drifted out of sight not the total duration. It's going to take a dead calm day to get a Swift or Hawk time on this bird. But there is no doubt . . . the Space Dart certainly does perform! Congratulations to Lew Walton on designing this bird.

## WHAT'S YOUR FAVORITE ARTICLE THIS MONTH?

Vote here for your favorite articles. List them in order - the most-liked first, etc.

1. \_\_\_\_\_
2. \_\_\_\_\_
3. \_\_\_\_\_
4. \_\_\_\_\_
5. \_\_\_\_\_
6. \_\_\_\_\_
7. \_\_\_\_\_

Clip this section out or use a facsimile. Paste on a postcard or enclose it in an envelope and send to:

**Reader Survey**  
**Model Rocketry Magazine**  
 Box 214  
 Boston, Mass. 02123

# MODROC CALENDAR

**Toronto Regional** — June 1971. Open meet for rocketeers from the Ontario, Canada area. Sponsored by the Canadian Rocket Society. Science teachers and their students are especially invited. Contact: CRS, Adelaide St., PO Box 396, Toronto, Ontario, Canada.

**Texas Wing Meet II** — June 12, 1971. Open model rocket competition, sponsored by the National Aerospace Program Sherman-Denison Squadron, for rocketeers from the five state area adjoining Texas. Events: Parachute Duration, Streamer Duration, Boost/Glide, Eggloft, and Payload. Contact: Oscar R. James, 403 W. Burton, Sherman, TX 75090.

**Phillipsburg Annual Convention & Record Trials** — June 18-20, 1971. Convention open to all rocketeers. Events: Discussion Groups, Manufacturers Displays, Lectures, Films, and Banquet. Record Trial Events (limited to NAR members): Hawk R/G, Condor B/G, Eagle R/G, Cl. 0 and Cl. 3 Streamer Dur., Hornet B/G, and Hornet R/G. Contact: David Klouser, 383 Warren St., Stewartville, NJ 08886.

**North Georgia Regional Meet** — June 18-19, 1971. Regional meet, sponsored by the Metro-Atlanta Society for Educational Rocketry, open to rocketeers from the Southeast. Events: Eggloft, B/G in Sparrow through Hawk categories. Site: near Atlanta, Georgia. Contact: Richard Wallace, 4676 Kingsdown Road, Dunwoody, GA 30338.

**Blackhawk Regional II** — June 19, 1971. Regional competition sponsored by the Blackhawk NAR Section of Rock Island, Illinois. Open to NAR members from Indiana, Ohio, Illinois, Iowa, Wisconsin, and Minnesota. (Advance registration before April 10, 1971 is required.) Events: Drag Race, Sparrow B/G, Hornet B/G, Cl. 2 PD, Cl. 1 Streamer Dur., and Pigeon Eggloft. Contact: Glenn Scherer, 1427 Seventh Ave., Rock Island, Ill.

**SPAM-4** — June 20, 1971. Area meet sponsored by the YMCA Space Pioneers of New Canaan, Connecticut. Events: Scale, Pee Wee Payload, Class 1 altitude, Robin Egg Loft, Predicted Altitude, Eagle B/G, Sparrow R/G, and Parachute spot Landing. Contact: A. Jacobsen, 351 Springwater Lane, New Canaan, Conn. 06840.

**Burnaby Invitational** — June 26-27, 1971. Contest in Burnaby, British Columbia, open to both Canadian and US rocketeers. Events: Class 0 Altitude, Open Spot Landing, Sparrow B/G, Class 1 PD, and Robin Eggloft. Features: Guest Speakers, Manufacturers Displays, Planetarium Visit, Banquet, Trophies, etc. Contact: BCC-RM Contest Director, 6714 Hershman Av., Burnaby, British Columbia, Canada.

**MMRR-71** — June 26-27, 1971. Regional meet in Columbus, Ohio, open to NAR members from the Midwest. Events: Scale, Swift B/G, Hornet B/G, Sparrow Rocket/Glider, Robin Eggloft, Predicted Altitude, Plastic Model, Class 0 PD, and Class 2 Streamer Dur. (Advance registration required.) Contact: MMRR-71, 1191 Shanley Dr., Columbus, Ohio 43229.

**Texasarea II** — June 26-27, 1971. Area meet sponsored by the Apollo-NASA Section and open to NAR members from the state of Texas. Site: Manned Spacecraft Center, Houston. Contact: Gary King, 13903 Barryknoll Lane, Houston, Texas 77024.

**Canadian Convention** — July 2-4, 1971. Second National Canadian Model Rocket Convention, sponsored by Montreal's ARRA club, and open to all rocketeers. Discussion groups, films, speakers, competition, and a banquet. Full information from: ARRA, 7248 2nd Ave., Montreal 329, Quebec, Canada.

**SRAM-2** — July 3-4, 1971. Section meet sponsored by the Sulphur River NAR Section, Sulphur River, Texas. NAR members in East Texas may compete. Events: Class 1 PD, Sparrow B/G, Class 0 Drag Efficiency, Open Spot Landing, Class 00 Altitude, and Class 2 Streamer Duration, Contact Danny Miller, 804 Glimmer St., Sulphur Springs, Texas 75482.

**HARM-1** — July 9-11, 1971. The Heart of America Regional Meet, sponsored by the Midwest Rocket Research Association, is open to NAR members in the Midwest. Events: Super Scale, Sparrow B/G, Hawk B/G, Roc Eggloft, Dual Payload, Class 1 PD, and Open Spot Landing. Contact: Jim Spilker, 8805 W. 80th St., Overland Park, Kansas 66204.

**NSSR-71** — July 17, 1971. Regional Meet sponsored by the North Shore Section of the NAR, open to all NAR members from the New York, New Jersey and Connecticut area. Events: Scale, Eagle B/G, Sparrow B/G, Streamer Duration Class 1, Open Spot Landing Class 0 PD. Registration Deadline: May 22, 1971. Contact: Kevin Clark, 167 Dorchester Rd., Garden City, New York 11530.

**Southwestern Model Rocketry Conference** — July 20-23, 1971. Third annual convention for rocketeers in the Southwestern US. Featuring: flight competition, discussion groups, speakers, films, and banquet. Sponsored by the ARC-Polaris Rocket Club, Portales, New Mexico. Write for information: ARC-Polaris, Awarer 89, Portales, N. Mex. 88130.

**East Penn-2** — July 25, 1971. Area meet sponsored by the Pottstown Missile Minders of Pottstown, Pennsylvania. Events: Ostrich Eggloft, Class 1 PD, Class 2 PD, Class 2 Streamer Duration. Contact: Carl J. Warner, 665 Woodland Ave., Pottstown, PA 19464.

**TCIRM-1**—August 21-22, 1971. Tri-County Invitational Rocket Meet open to all rocketeers in the Colorado area. Sponsored by the Model Rocket Club of Thornton, Colorado. Site: Adams County Fairgrounds. Events: Class 2 PD, Scale, Sparrow B/G, Single Payload, Robin Egglofting, and Open Spot Landing. Contact: Tom Sloan, 2081 Hoyt Dr., Thornton, Colo. 80229. (Advance registration before August 1st is required.)

**AARM-2** — August 21-22, 1971. The Second Annual Alberta Regional Meet is open to all rocketeers from Alberta, British Columbia, and Saskatchewan. Events: Class 1 Altitude, Class 1 PD' PeeWee Payload, Pigeon/Ostrich Eggloft, Swift B/G, Hawk B/G, Scale, Parachute Spot Landing, Site: Edmonton, Alberta. Contact: AARM-2, 10635-48 St., Edmonton 80, Alberta, Canada.

**Montreal Eggloft '71** — September 18, 1971. Regional Egglofting competition in Montreal, Canada. Site: Maisonneuve Park complex, Montreal. For rules and information write: ARRA, 7800 des Erables Ave., Montreal 329, Quebec.

**Wisconsin Area Meet** — September 18, 1971. Contest, sponsored by the Mariner Rocket Society, open to all NAR members from the state of Wisconsin. Events: Class 0 PD, PeeWee Payload, Robin Eggloft, Hornet B/G, and a non-sanctioned Payload Boost/Glide event. Contact: Russ Schmunk, 118 Highland St., White-water, Wisconsin 53190.

**ATTENTION CONTEST DIRECTORS**  
Mail notices of your contests at least 90 days in advance for listing in Model Rocketry's "Modroc Calendar" to:  
Modroc Calendar  
Model Rocketry Magazine  
Box 214  
Astor Station  
Boston, MA 02123

ON THE SCENE REPORT FROM THE FIRST RECORD TRIALS  
EVER DEVOTED EXCLUSIVELY TO BOOST/GLIDE FLYING...

# East Coast Boost/Glide Championships

by George Flynn

Boost/gliders of all types and configurations appeared in Bethlehem, Pennsylvania for the first East Coast Boost/Glide Championships over the April 23-25 weekend. The variety was amazing with kits from all the manufacturers, gliders built from published plans, and numerous home designs all set to compete in the first Record Trials devoted exclusively to Boost/Glide events. Sponsored by the ABM Section, the purpose of the meet was to fill in some of those "vacant" spots in the record book. Prior to the contest, only nine B/G records had been filed under the new Sporting Code rules, while six B/G events flown in four age divisions allowed for 24 potential records. Thus in some age divisions and events, any "qualified flight" could be filed for a U.S. record.

The launch site was several adjacent fields of the Lehigh University athletic facility. Overall, the flying area measured about ½ mile

across and about a mile long. It was divided into separate fields by rows of trees, but there were so few that losing a B/G into the trees posed little problem. They would, however, hamper the timing since a glider going down on another of the fields would be invisible from the launch area. Basically, it was a flat, grass covered field with a few small access roads and a parking lot. If the weather had cooperated, there would have been plenty of opportunity for thermals as well as updrafts at the tree line.

As the contestants arrived on Friday, the weather was good — the temperature was in the high 50's and the wind was gusting to only about 10 mph. For the contest, however, it wasn't to be that way. By 9:00 AM Saturday about 20 rocketeers were out at the launch field madly glide trimming a wild assortment of B/G's. Even before the first flight of the day, a strong wind came through lifting the contest cards, literature, and even boost/gliders into the air. Some of the flight cards turned in durations of over 30 seconds.

Jon Robbins, who had driven 10 hours from Western Ohio to participate, observed that "it's a bad day to be flying gliders."

It took a lot of coaxing to get anyone to put a rocket on the pad in winds that were gusting past 20 mph. The first rocket off the pad was a Sparrow B/G by the team of Jon Rains and Steve Streiker. The wing broke off during the boost, perhaps as a result of a wind gust, and the flight was DQ'ed.

The only really spectacular flight on Saturday came early in the afternoon. Steve Klouser entered a styrofoam winged Bumble Bee in the Sparrow Class. He used standard Bumble Bee dimensions (MRM December '69) but substituted a DB Industries styrofoam wing for the balsa wing. The boost was good, and the B/G glided much better than should have been expected in the high gusting wind. It was timed for 114.6 seconds before the timers lost sight as the small glider was blown downwind.

Flights were few and far between on Saturday, and entries in all four scheduled

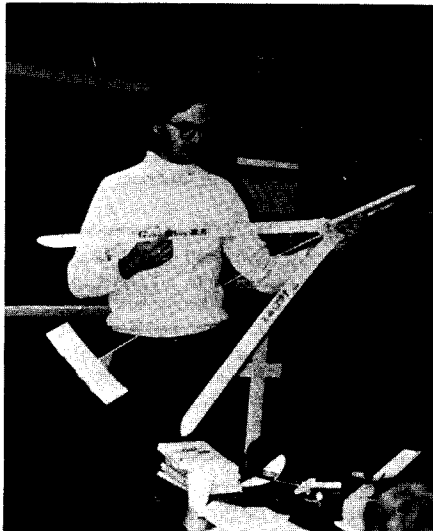

Jon Robbins uses the evening discussion session to explain the operation of his swing-wing "Ground-Hog" to the other contestants. The Condor version has a 6 foot span and 2 inch chord when unfolded. To further minimize drag during boost, a flop-wing stabilizer was used.



Steve Klouser discusses his first place winning styrofoam Bumble Bee which turned in a duration of 114.6 seconds in Sparrow B/G—the only really successful flight during Saturday's session. These discussions provided rocketeers with the opportunity for exchange of ideas previously found only at conventions.

Categories — Sparrow, Hawk, Condor, and Hornet — were permitted. But when the wind started gusting past 40 mph and dark clouds threatened rain, the flight session adjourned for the day.

Contest Coordinator Doug List quickly came up with an alternate plan to allow most, if not all, of the flying to be held on Sunday — flights would start at 8:00 AM and continue till 4:00 PM with all B/G categories going simultaneously.

Most of the modelers made a quick trip to Mac's Hobby Hall in Bethlehem to buy supplies for construction of some of the gliders for Sunday's events. The ABM Section had arranged for work space at the Bethlehem YMCA, so the windy and rainy afternoon was not a total loss. One room was available for construction session offered an opportunity for construction of models and the gym was used for glide testing. The construction session offered an opportunity for modelers to exchange ideas on their designs — a feature notorious by its absence at most contests.

This was carried even further after dinner when a discussion session led by Dick Fox



On Saturday afternoon, when high winds forced cancellation of the day's launching, a construction room was set up in the YMCA. Here Danny Sternglass is assembling the Thermic B which he flew to a first place in Hawk on Sunday.

### East Coast Boost/Glide Championships

#### Hornet B/G

Div. A	1st	Edward Bachman	6.0 sec.
Div. B	1st	David Shucavage	44.8 sec.
Div. C	1st	Mike Ackerman	42.7 sec.
Div. D	1st	James Frankenfield	21.7 sec.

#### Sparrow B/G

Div. A	1st	Danny Sternglass	9.2 sec.
Div. B	1st	Steve Klouser	114.6 sec.
Div. C	1st	Rich Brandon	44.2 sec.
Div. D	1st	George Flynn	42.5 sec.

#### Swift B/G

Div. A	1st	Danny Sternglass	43.2 sec.
Div. B	1st	David Shucavage	52.7 sec.
Div. C	1st	Dave Crafton	18.0 sec.
Div. D	1st	George Flynn	78.0 sec.

#### Hawk B/G

Div. A	1st	Danny Sternglass	35.5 sec.
Div. B	1st	David Shucavage	44.5 sec.
Div. C	1st	David Crafton	57.1 sec.
Div. D	1st	Tom Ackerman	81.0 sec.

#### Eagle B/G

Div. A	1st	no qualified flights	-----
Div. B	1st	David Shucavage	29.1 sec.
Div. C	1st	David Crafton	72.0 sec.
Div. D	1st	Tom Ackerman	121.0 sec.

#### Condor B/G

Div. A	1st	no qualified flights	-----
Div. B	1st	no qualified flights	-----
Div. C	1st	David Crafton	63.2 sec.
Div. D	1st	no qualified flights	-----

considered the question of what designs everyone was flying, and what performances they had turned in during the first day's flying. Rocketeers with unusual designs or new concepts were given an opportunity to present their ideas to the rest of the group.

Perhaps the most "unusual" design discussed was the "Ground Hog" swing-wing B/G developed by Jon Robbins. Actually, he had nine "Ground hogs" at the meet — one for each of the six events and back-ups for some. These swing-wing gliders use an extremely high aspect ratio wing (a six foot span with a two inch chord on the Condor version) and a very flexible boom. On the larger versions, a flop wing stabilizer is also employed. The swing-wing concept was used to allow high boost altitudes while not compromising the glide performance. After listening to the description of the "Ground-hog's" flight performance, everyone was anxious to see what durations they would turn in on Sunday.

The weather report wasn't too encouraging. Doug List announced at 10 PM that "tomorrow's weather is predicted to be more of today's." Even more disturbing, a quick look out the window indicated that the rain had changed to hail and intermittent snow flurries (on April 24th!).

At 6:00 AM Sunday morning the local Bethlehem radio station reported a temperature of "35 degrees outside, partly cloudy, with a 20% chance of rain in the early afternoon." But since the rocketeers had traveled some distance to fly B/G's, a little adverse weather wasn't about to discourage anyone.

It was decided to fly all six events simultaneously. By 8:30 AM, in 40 degree temperatures and winds of 15 to 20 mph, there were about 20 rocketeers out on the range, and plenty of rockets were on the pads ready to go. The first two flights of the day, both Hornet B/G's were, DQ'ed because of engine ejection.

In the high gusts it was a bad day for Hornets, though some of them did manage to avoid being torn apart by the wind. The most popular entry was the Bumble Bee, with nine of them being flown. There were also three Wasps, two Unicorns, Flatcats, and



Dave Crafton displays his Condor parasite just before its contest winning flight. The black tape all over the booster was necessitated by a recovery system failure on its first flight. The Bumble Bee parasite turned in a 63.2 second duration, the only good flying Condor at the meet.



This unusual swing-wing entry was Jon Robbins' "Ground Hog" series—one in each size for the six B/G events. This one is the Sparrow, which boosted straight up but the right wing failed and the duration was only 12 seconds. Note the very high aspect ratio wings.

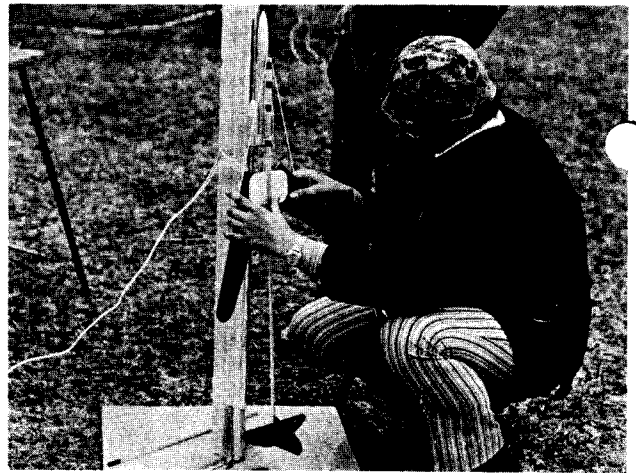

This unusual Eagle entry was described as "a FlatCat, slightly modified with rounded wing tips, and airfoiled swing-wings."

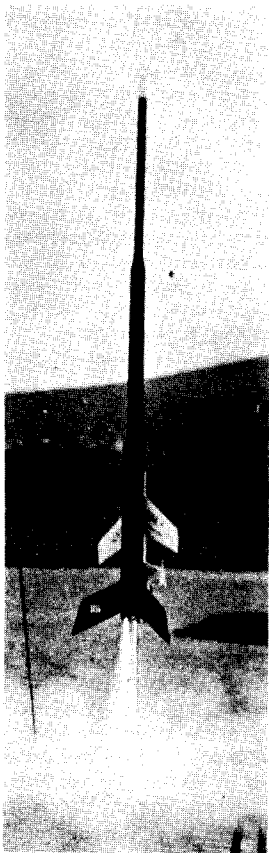

The Streicher-Rains Condor parasite—a Thunder-Bird B/G strapped to the side of a "Universal Booster" powered by a 3-D cluster—lifts off. Premature separation of the glider resulted in an 11.8 second duration.

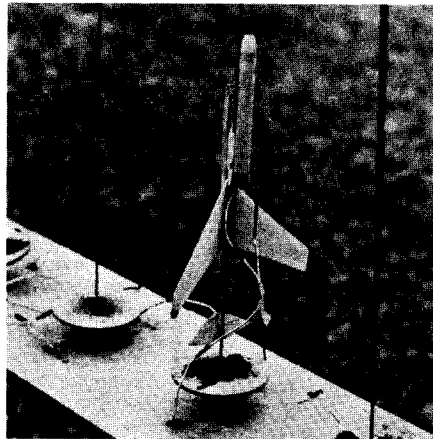

George Flynn's Space Dart, powered by a B6-3, took first in the Swift competition when it went out of sight after 78.0 seconds.

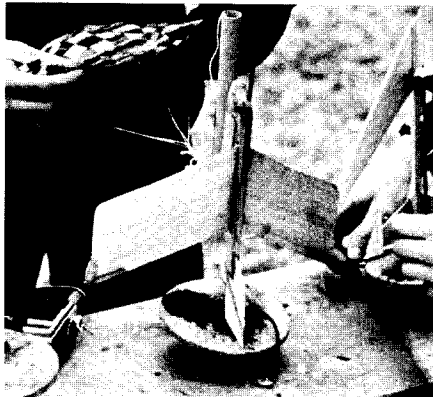

Dave Crafton's MiniBat was flown in the Hawk and Eagle events, and it took first place in both. The pod was redesigned to allow high-powered engines to be used, and the MiniBat turned in 57.1 seconds in Hawk, and 72.0 seconds in Eagle.



Contest Coordinator Doug List displays his unusual Sparrow B/G—a Bumble Bee parasite attached "backwards" to a normal sized model. This novel idea failed when the glider did not separate from the booster.

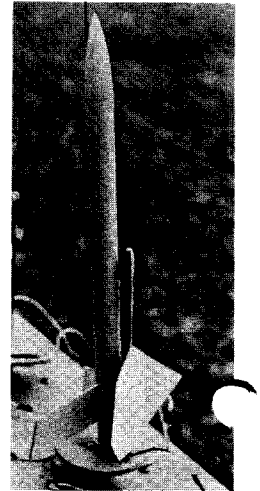

Richard Brandon's Condor entry was a parasite Manta on an F7 booster. It failed on three consecutive flights when the F7 sustaining thrust was too low to keep it in the air.



Danny Sternglass examines his Hawk and Eagle "Thermic B" model built on Saturday during the construction session, as flown to first place in A Division Hawk with 35.5 seconds. Earlier the "Thermic B" turned in 102 seconds, but was DQ'd when the streamer ripped off the pod.

Falcons, and one Ground Hog, a Thermic Dart, a half-size Jiskra, and two home designs.

The heavier Falcons retained their pods and ejected only the engines with attached streamer and had better glides in the gusty weather. However the best overall flight was a Wasp, flown during a period of relative calm, built by David Shucavage, which turned in a duration of 44.8 seconds. This barely edged out Mike Ackerman's Bumble Bee which managed a 42.7 second duration.

Surprisingly, even though Sunday's weather was better than Saturday's, no one managed to beat Steve Klouser's 114.6 second Bumble Bee flight in Sparrow. Again, just about every type of glider was being flown, but "Red Barrons" were bringing down just about everything. By unofficial count, over 50% of the Sparrow flights were DQ'ed when the pop-pods hung up on the glider. In fact, the comment "Maybe the Europeans have the right idea in fixed pods," was heard frequently on the field.

As the Hornet event, Bumble Bees dominated the Sparrow field with seven of these gliders being flown. The FlatCat was next most popular with three being flown, followed by two Nighthawks, two Unicorns, a Thermic 20, a Manta, a Falcon, a Space Dart, a Groundhog, and four home designed gliders.

Sunday's good Sparrow flights were limited to a 44.2 second performance by Richard Brandon flying a Manta and George Flynn's 42.5 second duration flying a Space Dart (MRM April/May '71). The latter glider came down on its streamer to about 100 feet where the Space Dart finally separated and glided down.

In the Swift competition the gliders were boosting high enough that wind drift carried them out of range of the timers. The two best durations, separated by only 3.6 seconds were launched within minutes of each other, and both drifted away at about the same speed. Both were still in the air when the timers lost sight. The Space Dart, flown by George Flynn, turned in a duration of 78 seconds to barely edge out Jon Robbins Groundhog with 74.4 seconds. The Swift Groundhog was the only one of Jon's experimental gliders to perform perfectly, boosting straight up and deploying its swing-wings right on schedule.

The real interest at the East Coast B/G Championships, as at other recent contests, was in the high-powered events — Hawk, Eagle, and Condor. Almost all the contestants had something to fly in each of these events, and if they didn't they used the Saturday construction session to build something! In fact, Danny Sternglass' winning A Division Hawk was a "Thermic B" purchased at the bobby shop on Saturday and assembled that afternoon. Though it was a little heavy and large (36" span) for the Hawk event, it managed a 102 second flight with the same glider, but was DQ'ed when the streamer ripped off the pop-pod.

The best flying Hawk was a Manta built by the Contest Director — Tom Ackerman. The model was built to the original Manta plans, and did not employ the "auto-elevator" which Howard Kuhn has been using on some of his Manta's recently. In the windy weather, Tom Ackerman's Manta turned in a 91 second duration of its first flight. By that time it had been blown far enough down-range that recovery was impossible. In fact, the "non-



Bethlehem's Congressman Fred Rooney paid a visit to the East Coast B/G Championships, and launched several of the rockets. He was quite impressed with a special Saturn V demonstration flight, and invited the sponsoring ABM Section to visit his Washington office later in the year.

return rule" got a thorough workout at this contest.

The Eagle event was one in which two conflicting competition strategies became apparent. The first was that a high-powered B/G should be just a strengthened "standard" glider. Recently, however, the use of a small "parasite" glider attached to a standard rocket is gaining popularity. In the Eagle event "standard" B/G's outnumbered the parasites ten to six. In terms of impressive flights, however, it was a clear victory for the "standard" boost/glidern.

Tom Ackerman brought out his second Manta — this one a strengthened version using 3/32" thick wing surfaces — for a 121 second flight. This topped all the other Eagle gliders by almost a minute.

In second place was David Crafton's Mini-Bat, which used an enlarged pod to accept two C-engines. This model turned in a 72 second duration on the windy afternoon. The heavy, almost overbuilt, models were the only ones which could maintain a glide in the gusty wind.

David Shucavage managed a third place flying a Thunder Bird. He managed a duration of 29.1 seconds. Thus, all three of the good performances went to the standard gliders, the parasites just didn't perform.

In Condor it was a different story — both of the qualified flights were parasites! Dave Crafton's Condor B/G was a monokoted version of the Bumble Bee, using Bob Singer's plans in the December '69 MRM, strapped to the side of a "Big Bertha" sized booster rocket. The bird was powered by two D13's and a 1/4A to put it just barely into the Condor class. On its first flight the boost was perfect, but the chute stripped from the rocket and the glider did not separate. The timers timed the wadding for over a minute before realizing that it wasn't the glider. The Bumble Bee went undamaged in the impact, though the front end of the rocket was crushed.

Not wanting to give up so easily, Crafton used the better part of a roll of masking tape "rebuilding" the booster rocket. About an hour later it was ready for its second Condor flight. Again the boost was perfect, and this time the Bumble Bee separated

cleanly from the booster. It worked perfectly, turning in a 63.2 second duration — the best Condor time of the meet.

This marked the third time that Condor has been flown in the Northeast, and the third time that Crafton has won the event. At NART-1 last spring the Lieberman-Crafton team topped the field with 52 seconds flying a parasite "Micro-Manta," built at the contest, strapped to their egglofter. At MARS-V the Fox-Crafton-Stolzenberg team took first place in the D-Division with 86 seconds flying a Nighthawk parasite B/G. Crafton's victory at ECBGC using a Bumble Bee parasite seems to indicate that he's "sold" on the parasite concept for the Condor event.

The only other Condor B/G to make a qualified flight was another parasite flown by Richard Brandon. He used a Manta parasite attached to an F7 powered booster. The Manta stripped off during boost, giving a duration of only 7 seconds. However, the booster was recovered safely, and the flight was ruled "qualified" by the RSO.

A number of the DQ's incorporated new design techniques which may prove successful in future contests. Jon Robbins' "Groundhog" swing-wing seems especially promising. Using a six foot wing span with a two inch chord Jon gets 144 square inches of wing span area into the air. However, the frontal area during boost is much smaller than the standard configuration glider since the wings are swung parallel to the body during the boost. Flying with 2E's this bird really flexed during boost. It looked like it was trying to shake itself apart, but it held together thru the five second boost. Unfortunately the deployment system was damaged, and the wings opened only partially. A little more strengthening of the deployment system, and the swing-wing looks like a good performing bird.

The East Coast Boost/Glide Championships concluded with the formal presentation of awards. After the closing ceremony there was a mad rush of successful rocketeers to get the required signatures on flight cards and record applications. All in all, existing US categories, some as a result of no previous records existing and others because of good flights.

# AMT Saturn-V

## A Plastic Conversion

by John Frankosky

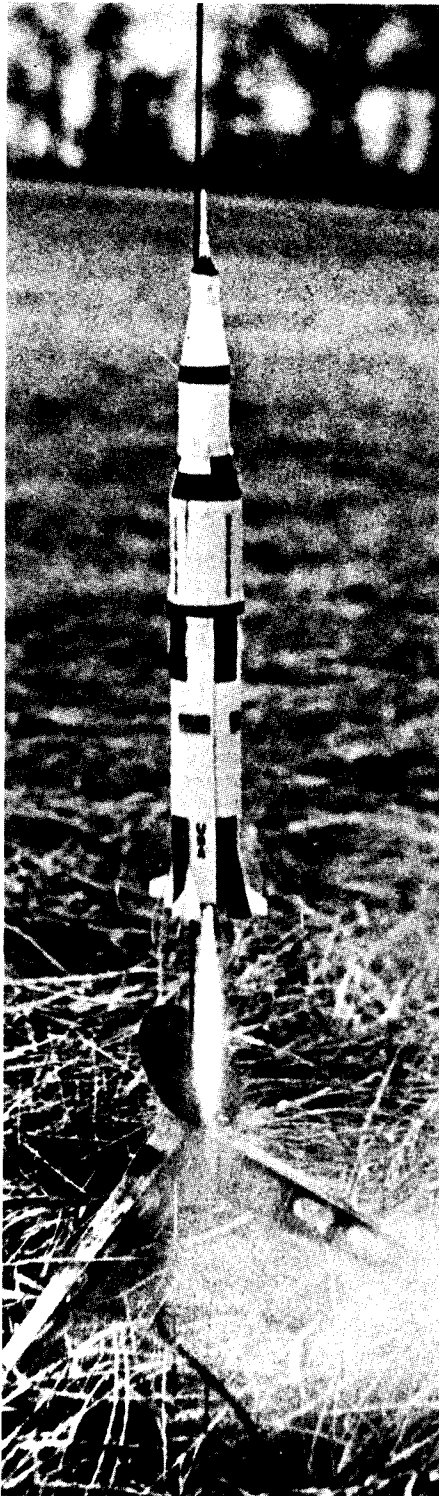

Liftoff! The flight converted AMT Saturn flies quite well with a C6-3 engine, and the conversion itself is fairly simple.

While a number of plastic kits have been converted for flying, the AMT Saturn-V model allows what is perhaps the most straightforward approach to conversion. It should offer no difficulty, even for the beginning rocketeer. Few changes, other than the elimination of several of the hidden plastic parts, are necessary. Only one of the plastic bulkheads must be altered, and the change is neither difficult nor critical. Clear plastic fins are added for stability. In flight testing, the model boosted straight and true with a C6-3.

The conversion was made with Space Age Industries parts, since their 45 mm tube is a beautiful fit for the inside of the AMT Saturn's first stage. This tube provides insulation for the heat sensitive plastic tube, and accurate alignment for the 19 mm engine tube. The arrangement is so logical that it is not necessary to glue the engine mount to the plastic tube — the bulkheads hold it accurately in place. As an added bonus, the plastic engines can be snapped into place to make a beautiful display model.

The AMT Saturn V kit is available, by mail, from Lectronix (Box 42R, Madison Heights, Mich. 48071) for only \$1.75 postpaid - a substantial saving off list price. A complete conversion kit is available from Space Age Industries (Dept. L., Box 1225, Highland Park, NJ 08904).

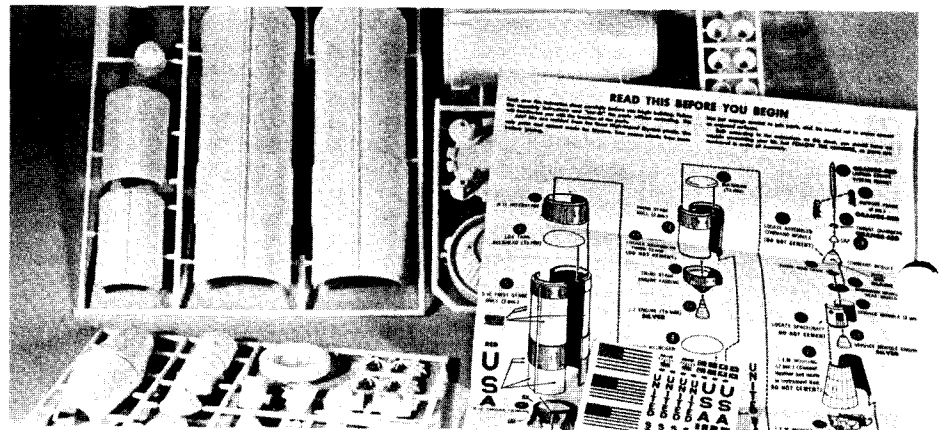

1. The AMT Saturn-V kit includes molded plastic parts, assembly instructions, and colorful decals. It makes such a nice display model that the flight conversion has been designed to allow use of the display nozzels except when the model is actually being flown.

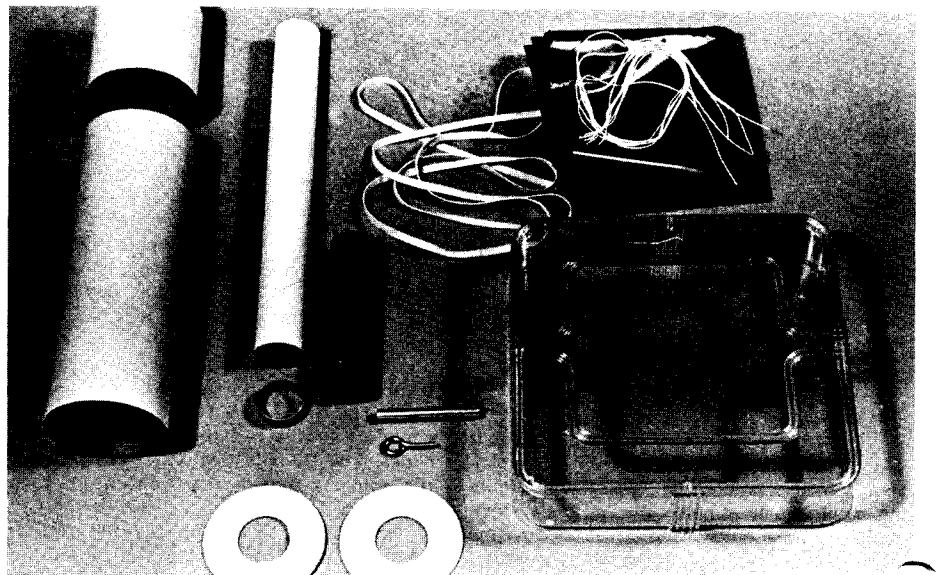

2. Flight conversion requires two 45 mm diameter body tubes, one 19 mm tube, one engine block, two 45 mm to 19 mm mounting rings, one aluminum launch lug, screw eye, shock cord, and a 12" (or larger) chute. A complete conversion kit is available from SAI.



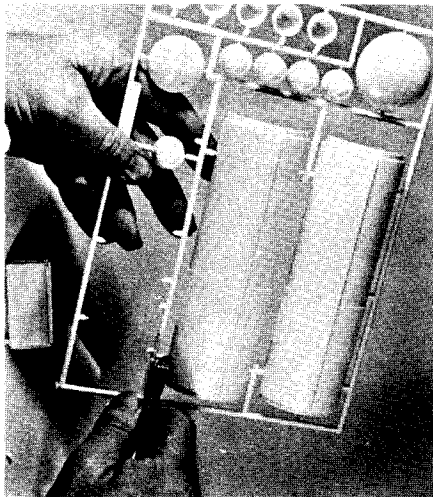

3. The molded plastic parts should be carefully cut away from the "trees" using a sharp cutting pliers or X-Acto knife. A little care here will result in a nicer surface on your finished model.



4. Mark a line on a dummy engine  $\frac{1}{4}$ " from an end.



5. Smear a small quantity of white glue — Elmers or Ambroid Se-Cur-It — inside the 19 mm tube about  $2\frac{1}{2}$ " from the end.



6. Insert the engine block, and use the dummy engine to push the engine block into the 19 mm tube. Stop at the  $\frac{1}{4}$ " mark on the dummy engine.



7. Use an adapter ring to mark a 19 mm circle on the lower stage engine fairing bulkhead.

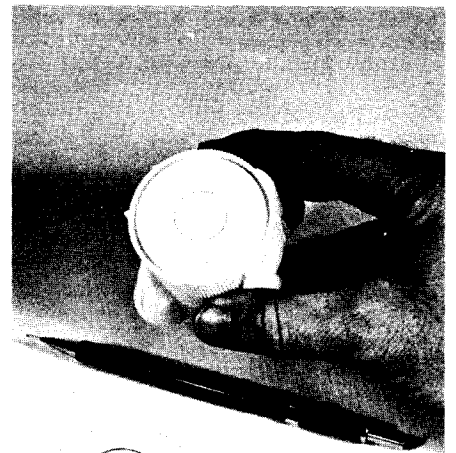

8. The circle indicates the portion of the bulkhead which must be cut away to allow clearance for the engine.



9. Place a bead of glue just inside the edge of a  $5\frac{1}{2}$ " length of 45 mm tube, and glue a 45 mm to 19 mm adapter ring in place.

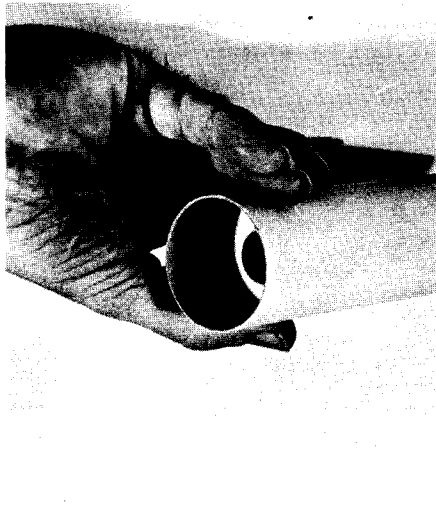

10. Recess the second adapter ring  $\frac{1}{4}$ " from the opposite end of the tube, and glue it in place. Allow this assembly to dry.



11. Glue the 19 mm engine tube in place. It should extend  $1\text{-}\frac{3}{16}$ " from the flush adapter ring.

# For Beginners And Advanced Rocketers

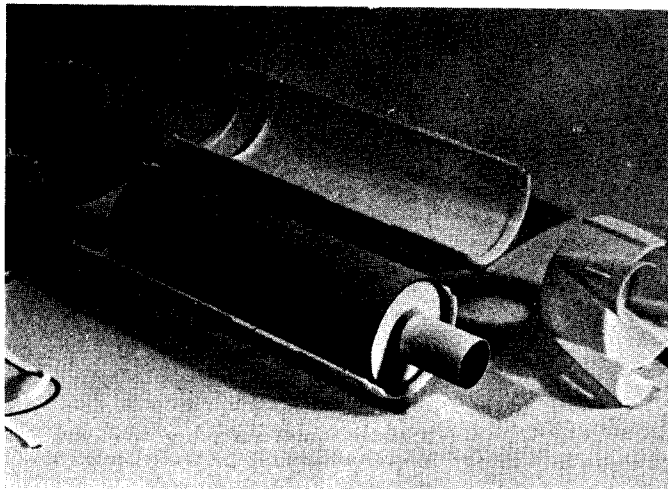

12. Test fit the engine holder assembly in the first stage hull halves. The 45 mm tube is such a good fit you should find there is no need to glue it in place.

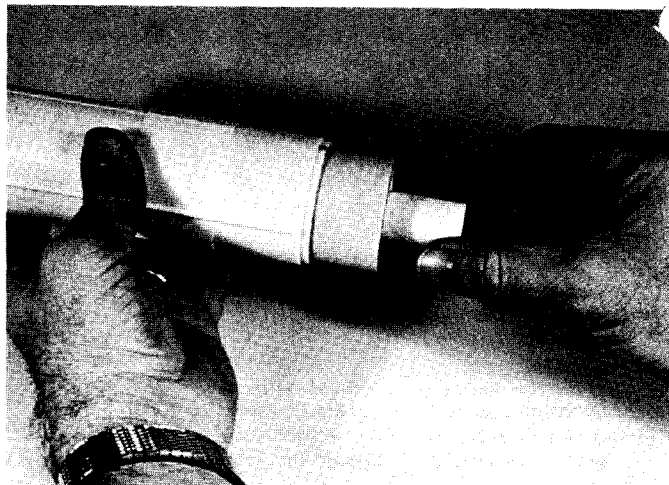

13. Glue the main stage body sections together using liquid plastic cement. Then insert the engine holder into place. The plastic engine fairing will lock the tube in place.

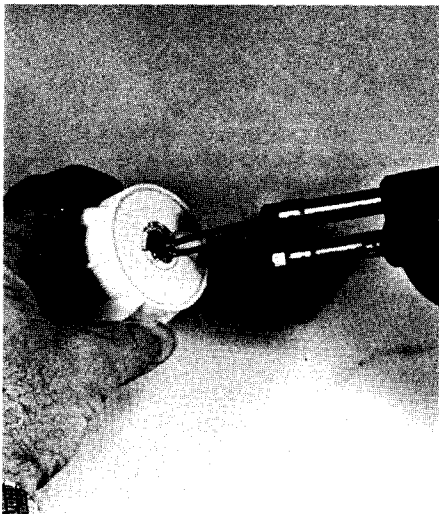

14. Use a hot soldering iron to melt away the marked center of the engine fairing bulkhead.

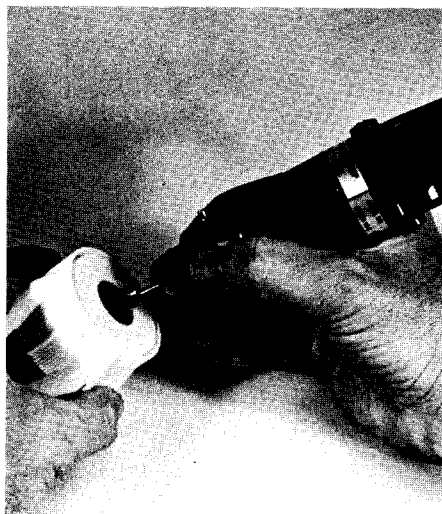

15. A Dremel Moto-Tool can then be used to dress the rough edges and provide a circular hole in the bulkhead.

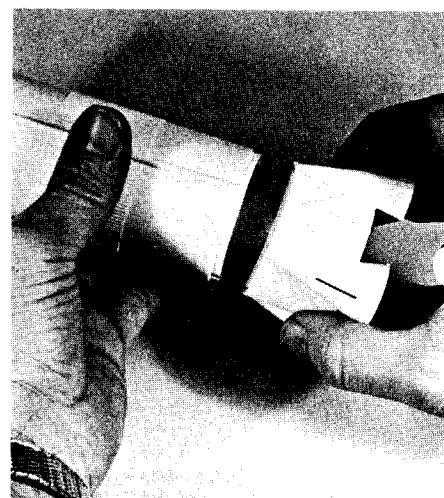

16. Test fit the engine fairing section on the first stage hull. If the hole in the bulkhead is not large enough, correct it with the Dremel tool.

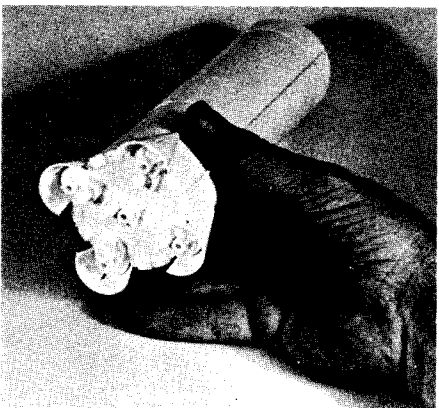

17. Snap the display fuel manifold into place. If it fits well, remove the display manifold and cement the engine fairing to the hull. If it doesn't fit, trim the 19 mm engine tube until the display manifold fits.

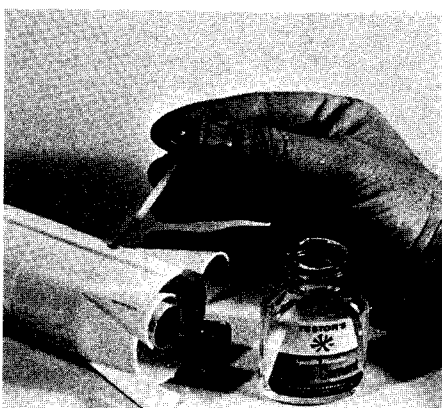

18. Testors liquid cement applied to the outside of the model will flow into the joint giving a good bond.

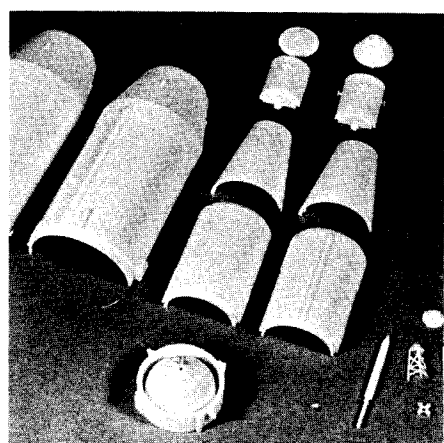

19. The upper stage parts are assembled to form one solid unit. Glue the entire upper section with liquid cement to avoid having the rocket "come apart" in flight.

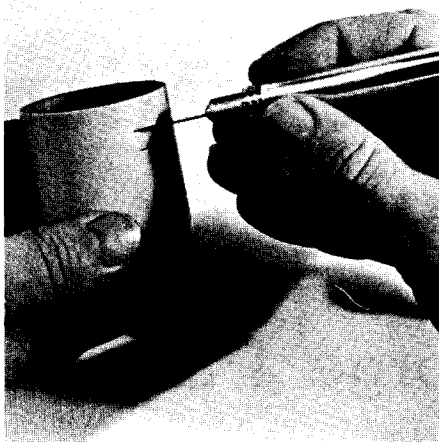

20. Make two parallel slits in the 1-7/8" length of 45 mm body tube.

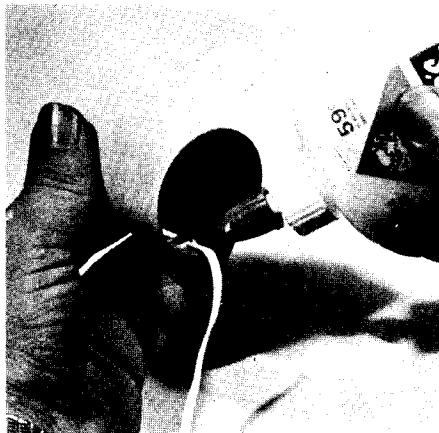

21. Thread a piece of shock cord through the two slits, and apply glue to attach it securely in place. When the glue is dry, tie a knot in the shock cord for added protection.



22. The 45 mm tube is securely glued in place in the interstage adapter between the first and second stages. (Use Testors Plastic Model cement in tubes.)



23. Four clear plastic fins are cut from the top of a plastic box or from Estes clear fin stock (CFS-40). The full size template at right should be used as a fin pattern. No additional nose weight is necessary if these fins are used.

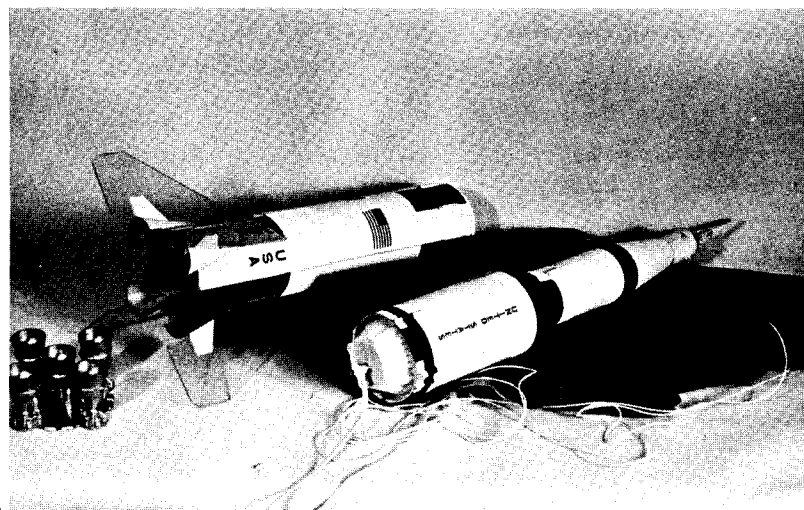
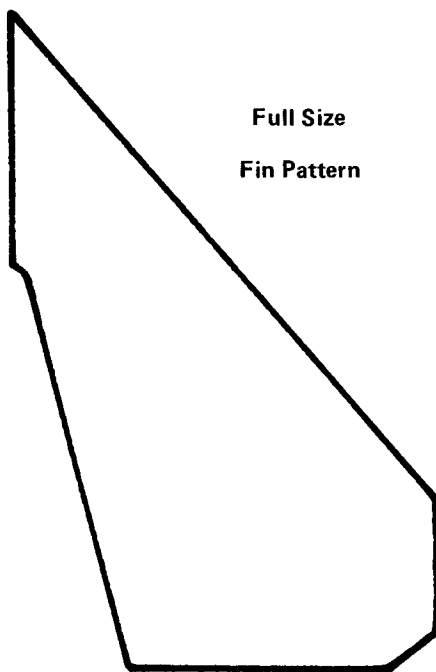

24. Drill a hole in the rear bulkhead of the second stage, epoxy a screw eye in place, and attach the other end of the shock cord which was previously fastened to the first stage. Add a 12" to 18" chute, a launch lug, and your model is ready to fly.



25. The AMT Saturn V also makes quite a nice display model when you install the display nozzles. Flights should be made with a single C6-3, which was used in flight testing, or the new Cox D8-3. This model is really quite an impressive performer, with flights to several hundred feet on a single engine. As with all Saturn models, it is really a "crowd pleaser" at demonstration launches. It can also be flown in the Plastic Model competition event. Good luck!

# Model Rocket Drag Reduction by 'Boat-Tailing'

by George Pantalos

*(Editor's note: This is the first of a two part article which will consider "boat-tailing" a model to reduce its aerodynamic drag forces. Part one will discuss the basic boat-tailing concept. Part two will continue the discussion with wind tunnel analysis of boat-tailed and non-boat-tailed model rockets, as well as the basic application of boat-tails on models.)*

When designing and constructing a model rocket, one factor which is upper-most in the mind of the model rocketeer is the aerodynamic efficiency of its design in regard to the minimization of aerodynamic drag forces. Several suggestions, such as the use of a smooth finish, a parabolic nose cone, and comparatively high (1.5 to 2.0) aspect ratio fins are usually offered as methods to reduce

drag.

It is true that the previous methods do aid in reducing drag. However, another method of reducing drag called "boat-tailing" should be considered by the designer.

### Drag and Base Drag

Aerodynamic drag can be defined as a retarding force which is the resultant of the interaction of a body with the air through which it is traveling. In a model rocket, several factors, namely the launch lug, interference, the fins, the base, and the nose cone and body tube contribute to the total drag force of a model. Figure 1 depicts this graphically.

It can be seen how much of the total drag ( $D_T$ ) each factor contributes percentage wise. Of special interest is base drag which contributes between 22% and 58% of a model's total drag ( $D_T$ ) depending on whether the airflow is laminar (smooth) or turbulent on the rocket's surface.

Base drag results from the separation of the airflow from the model rocket at its base. When the airflow separates, a wake, which

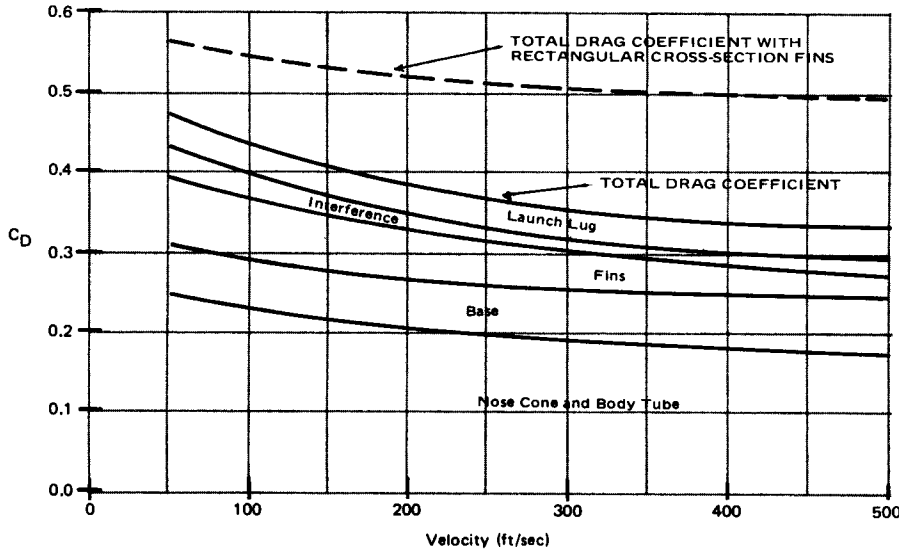

1a. Turbulent Body Tube, Laminar Fins.

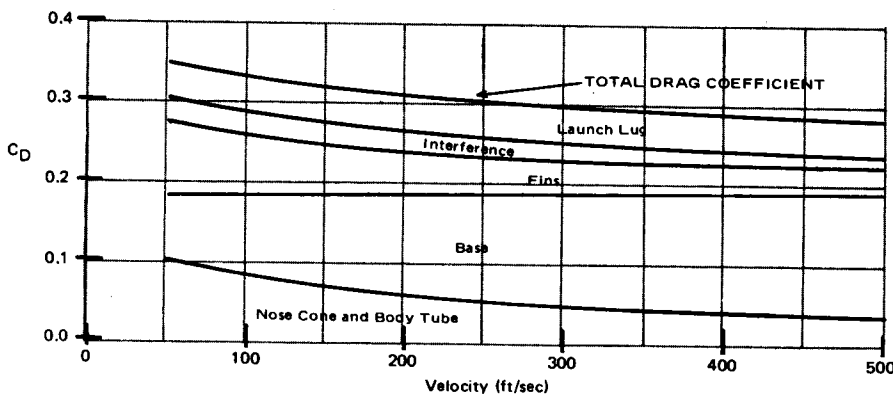

1b. Fully Laminar.

Figure 1: Components of drag on a model rocket (as analysed by Dr. G. M. Gregorek, 1970). Note that the Base Drag contributes a significant portion of the overall drag. "Boat-tailing" is an effective means of reducing the base drag.



Addition of a simple boat-tail at the rear of a payload model can result in overall drag reductions of as much as 25%.

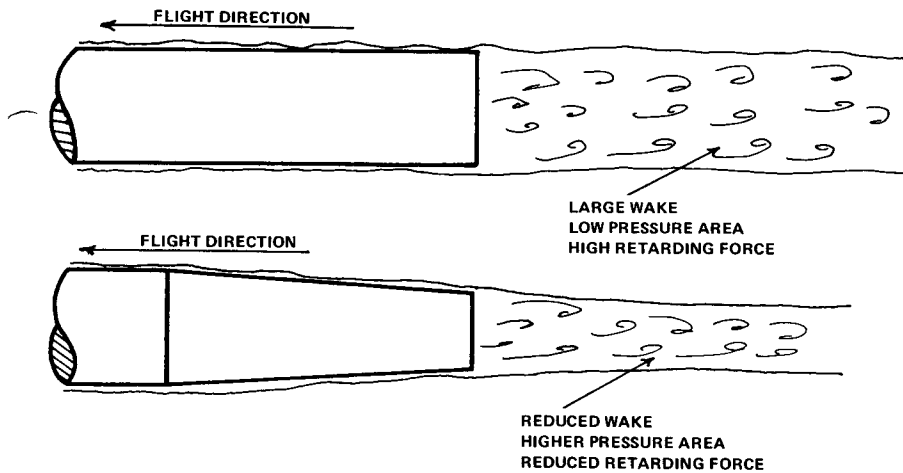

Figure 2: Boat-tailing a model rocket reduces the low pressure area behind the model. As a result the base drag is reduced.

contains a low pressure area, forms behind the rocket. Since objects move toward areas of lower relative pressure, the low pressure area in the wake acts as a retarding force by pulling the rocket in the opposite direction of its motion. If the low pressure area can be reduced (in effect, raising the pressure behind the rocket), the retarding force is reduced.

Reducing the low pressure area can be accomplished by gradually reducing the size of the rocket's body diameter-tapering or or "boat-tailing" the base of the rocket.\* If the airflow has not already separated from the rocket's surface it will follow the contour of the boat-tail reducing the wake, thus reducing the low pressure area and the base drag force. Figure 2 illustrates the boat-tailing effect.

The question is now raised, "How much drag does a boat-tail eliminate?" As stated in Dr. G.M. Gregorek's "A Critical Examination Of Model Rocket Drag For Use With Maximum Altitude Prediction Charts (1968)," the base drag is reduced by the cube of the rocket's base diameter divided by the rocket's

body diameter multiplied by the base drag of the same model without a boat-tail:

$$D_B(f) = D_B(i) \left[ \frac{DIA_{base}}{DIA_{body}} \right]^3$$

To give a dramatic example of this principle, consider an egglofter, powered by a "C" type engine, having an outside diameter of 1.84 inches. Two designs are to be considered. The only difference in design is that one has a boat-tail and the other does not. A drawing of the two rockets is given in Figure 3.

Using the previous expression, it can be determined that the boat-tailed rocket had  $(.75/1.84)^3 \times 1$  or 93% less base drag than the model which was not boat-tailed. In terms of the total drag ( $D_T$ ) of the rocket, this would mean that  $D_T$  would be reduced by almost 21%. This reduction in drag would mean a substantial increase in the model's altitude. As it was just determined, boat-tailing a model rocket can greatly improve its design and flight performance by effectively reducing base drag.

To get a better idea of how effective boat-tailing is, a brief wind tunnel analysis of boat-tailed and non-boat-tailed will follow in part two of this article.

\* the most efficient boat-tail is tapered at an angle between 5 and 7 degrees.

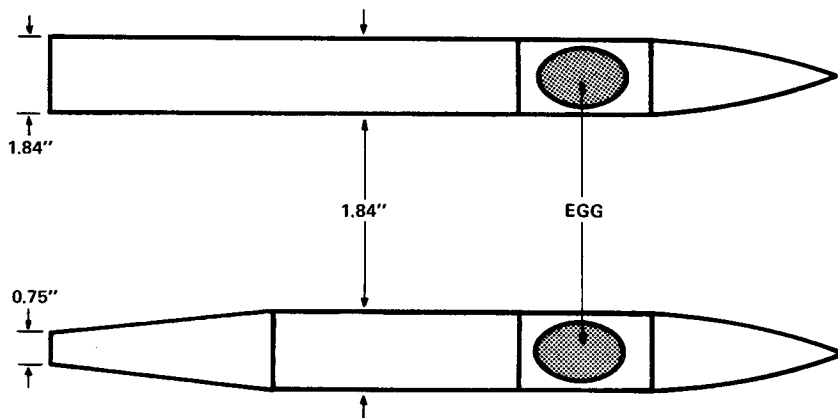

Figure 3: For comparison purposes two egg-lofting models, each 1.84" in diameter, were constructed. One used a straight cylindrical tube, while the second was boat-tailed. Theoretically the boat-tailed model has 21% less drag than the standard model resulting from the lessened base drag. (Actual wind tunnel measurements will be included in Part 2 of this article to be presented next month.)

## SPECIAL OFFER!

Beautiful, full-color photograph of the Apollo 7, Saturn 1B liftoff of October, 1968



This magnificent photograph of a most historic moment in the history of spaceflight was obtained by Model Rocketry editor George Flynn from an advance position not accessible to most Kennedy Space Center visitors. Showing the moment of liftoff, this 7 by 8 inch full-color print will make an inspiring addition to the album of any space enthusiast.

\*\*\*\*\*

Full-color copies of the photograph, which is reproduced in black and white above, may be obtained by sending 50¢, or \$1.00 for 3, to:

Saturn Photo  
**Model Rocketry**  
 Box 214  
 Boston, Mass. 02123

# UPDATE CANADA

## AARM-2 Scheduled

The second Annual Alberta Regional Meet (AARM-2) has been scheduled for August 21-22, 1971 at Edmonton, Alberta. Discussion Sessions, R&D Presentations, Displays, and Flight Demonstrations are planned. The following events will be flown:

Class 1 Altitude,  
Class 1 Para. Dur.,  
Pigeon/Ostrich Eggloft,  
Pee Wee Payload,  
Swift Boost/Glide,  
Hawk Boost/Glide,  
Scale,  
Parachute Spot Landing.

Trophies, ribbons, and special awards will be presented. All rocketeers from Alberta, British Columbia, and Saskatchewan are invited to compete. For further information and entry forms write:

ARRM-2  
10635 48th Street,  
Edmonton 80, Alberta

## First Canadian Modroc Company

Tag Powell, President of Space Age Industries (SAI), has announced the formation of Space Age Industries of Canada (SAIC), a Canadian corporation, completely independent of SAI.

SAIC is the first Canadian model rocket company. Under the direction of Vice-President Don Lewis, SAIC will produce the entire line of SAI model rockets and accessories. This will make SAI products available to Canadian model rocketeers at considerably lower prices than those of the imported kits.

SAIC invites Canadian distributor and dealer inquiries. The 1971 SAIC catalog is available to Canadian model rocketeers for 25 cents, in coin or stamps from:

Space Age Industries of Canada,  
Department MR,  
Post Office Box 88,  
Youngstown, Alberta CANADA

## Competition Tips

Looking through an old issue of *Estes Model Rocket News* (December 1967), I noticed an article on nose cone finishing. The article mentions toothpaste can be used as a rubbing compound (wax) to obtain mirror like finishes. Needless to say, the experienced rocketeer can employ this technique on his entire model.

Perhaps some modelers will even find it use different brands of toothpaste on different models:

Colgate (with the MFP protective barrier): useful on the egg capsule of your egglofter, Ultra Brite (the sex appeal toothpaste): used on your models when you find out in advance that the judges will be females,

Close Up (the toothpaste for close-ups): great for closely judged scale models.

Gee! Why didn't I think of that?

## Its Up to You!

We will try to write stories of general interest to everyone. But, we would like to make the format of the majority of articles come directly from you the readers. We in-

vite you to send in comments, pictures, scale plans, R&D projects, and almost anything else you have for inclusion to:

UPDATE CANADA,  
Articles,  
7800 Des Erables Avenue,  
Montreal 329, Quebec.

Note that if you would like your article returned include a stamped self-addressed envelope. We hope to hear from you soon.

# LeMans Start

by Steven J. Kushneryk

By now I think that every serious rocketeer has seen a copy of the Monroe Astros 'Purple Book.' And out of these people who have seen the book, at least 75% realize that the events described are not that far out and could be a lot of fun.

An event which seems to require a lot of imagination is the LeMans Start. This event requires that the rocketeer hook up his preped rocket, return to launch control, fire the rocket, recover it, and bring it back to the return table. The rocketeer completing this operation in the shortest time is the winner.

The rocket for LeMans Start competition has to be built with a lot of drag in mind. There are a lot of ways to do this, but Peter

Sauer of Montreal's ARRA club has come up with a rather unique design.

The rocket itself is nothing more than an inverted paper cup with a body tube attached to the inside. Clay weights are attached to the top (with short lengths of shroud line). There is no nose cone, since the object is to increase drag.

The rocket takes off straight up, with the mouth of the cup facing upwards. At peak altitude, which should be no higher than 10 feet, the rocket will arc over and fall. The mouth of the cup will be facing the ground, providing drag for recovery, since the clay weights sit to that end of the rocket.

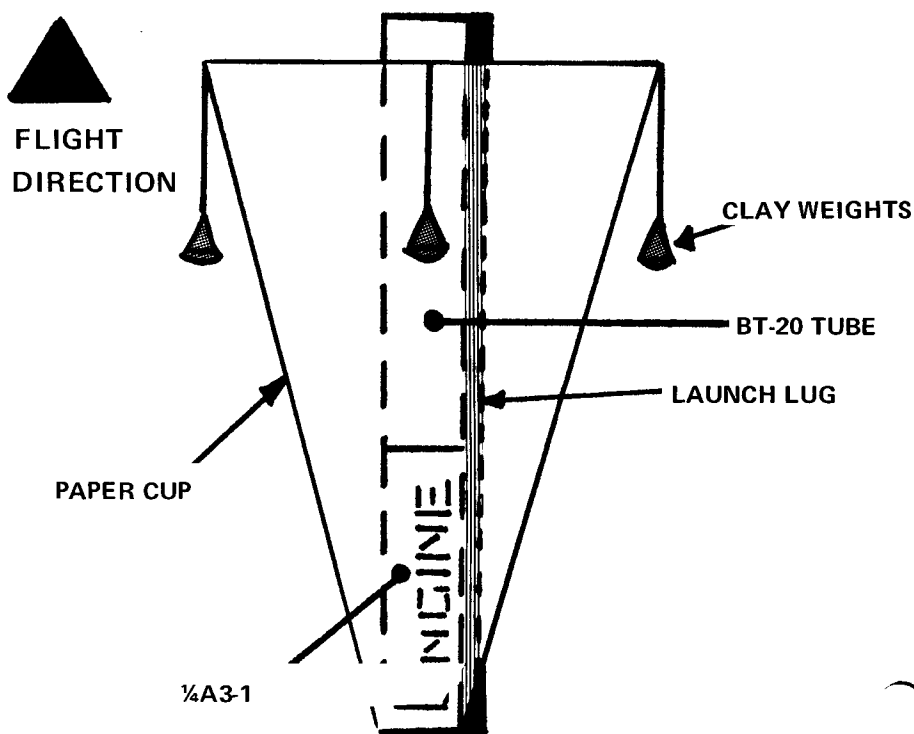

SJK

# Now! Join the all label Tape & Record Club for only \$5

## Save 33 1/3% on all 8-Tracks, Cassettes & LP Albums!

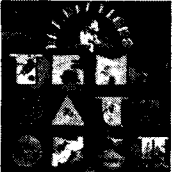
 <b>336 PARROT</b> I WHO HAVE NOTHING Tom Jones Series LP-E Tape-F	 <b>337 MOTOWN</b> THIRD ALBUM Jackson 5 Series LP-D Tape-F	 <b>338 METRO-MEDIA</b> WITH LOVE... BOBBY Bobby Sherman Series LP-E Tape-F	 <b>339 CAPITOL</b> CLOSER TO HOME Grand Funk Series LP-D Tape-F	 <b>340 PARROT</b> QUESTION OF BALANCE Moody Blues Series LP-E Tape-F	 <b>341 MOTOWN</b> NEW WAYS, BUT LOVE STAYS Supremes Series LP-D Tape-F	 <b>342 DUNHILL</b> STEPPEWOLF 7 Steppenwolf Series LP-D Tape-F
 <b>343 CAPITOL</b> BEACUPS OF BLUES Ringo Starr Series LP-E Tape-F	 <b>344 PARROT</b> GET YER YA YA'S OUT Rolling Stones Series LP-E Tape-F	 <b>345 MOTOWN</b> CHANGING TIMES Four Tops Series LP-D Tape-F	 <b>346 KING RECORD</b> SEX MACHINE James Brown Series LP-G Tape-H	 <b>347 CAPITOL</b> GOOD TIME ALBUM Glen Campbell Series LP-E Tape-F	 <b>327 METRO-MEDIA</b> GYPSY Gypsy Series LP-F Tape-F	 <b>349 CAPITOL</b> BAND OF GYPSYS Jimi Hendrix & Buddy Miles Series LP-E Tape-F

**Here's the one club** that will make it easy for you to buy everything in music . . . anytime you want it. Now you can enjoy all of the latest top hits . . . by top artists . . . on LP Albums, 8-Track Cartridges or Cassettes. And you can save a full 33 1/3% over regular retail prices.

**Imagine the thrill** of hearing all of the top stars . . . on all of the labels you want . . . before your friends even know where to buy them. Imagine having a whole galaxy of stars . . . like Tom Jones, Glen Campbell, The Jackson 5, Jimi Hendrix (name your favorites) . . . and have them as available as your nearby mailbox.

**No commitments whatever!** The Cartridge Tape Club of America is different from any other club you may have read about . . . or possibly even joined. As a member of this club you will *never be obligated* to buy any albums . . . as most other tape and record clubs demand! You can buy one album or a dozen. Or *none!* And, nothing will ever be sent to you unless you specifically request it.

**Free Tape and Record Guide!** As you know, there are guides galore and then there is *the* guide: The Glass List . . . the magazine tape and record guide that *sells everywhere for one dollar a copy.* But you, as a club member, will receive a subscription to the Glass List absolutely *free!* And you will know you have the most complete listings . . . including all the newest tape and record releases . . . in existence today. Each issue is also full of reviews, feature stories and informative articles.

**Save Now!** If you wish, you can start saving right away by ordering some tapes from those pictured above and from the sample list at right. To join, just complete the coupon. In column one, indicate the album(s) you wish to order by writing in the album(s) number. In column two, list whether you want the album ordered to be an 8-track tape (8-T), Cassette (C), or Stereo LP (LP). In column three, indicate the SERIES LETTER of the album you wish to order. (NOTE: the series letter for each album, which is shown in the list at right and under each picture, is different for LPs than it is for Tapes and Cassettes. Tapes and Cassettes have the same series letter.) In column four, list the Member's Price. If you want to order additional album(s) repeat the steps above. Then complete the coupon and return it with your check to the address shown.

ALBUM NUMBER	TITLE	ARTIST	LABEL	SERIES LP	TAPE
310	WE MADE IT HAPPEN—Engelbert Humperdinck—PARROT			E	F
321	STAGE FRIGHT—The Band—CAPITOL			E	F
322	IN CONCERT—Mantovani—LONDON			D	F
323	ONE WORLD—Rare Earth—MOTOWN			D	F
324	NATURALLY—3 Dog Night—DUNHILL			E	F
325	JUST FOR LOVE—Quicksilver Messenger—CAPITOL			E	F
326	EVERYTHING IS EVERYTHING—Diana Ross—MOTOWN			D	F
348	SHILO Neil Diamond BANG			D	F
328	I WOULDN'T LIVE IN NEW YORK CITY—Buck Owens—CAPITOL			D	F
329	LOOKING IN—Savoy Brown—PARROT			D	F
330	TEMPTATIONS GREATEST HITS V—Temptations—MOTOWN			D	F
331	INDIANOLA MISSISSIPPI SEEDS—B. B. King—ABC			D	F
332	1—Sonny James—CAPITOL			D	F
333	SIGNED, SEALED, DELIVERED—Stevie Wonder—MOTOWN			D	F
334	WE CAN MAKE MUSIC—Tommy Roe—ABC			D	F
335	ATOM HEART MOTHER—Pink Floyd—CAPITOL			D	F

SERIES LETTER	D	E	F	G	H
RETAIL PRICE	\$4.98	\$5.98	\$6.98	\$7.98	\$8.98
MEMBER'S PRICE	\$3.33	\$3.99	\$4.66	\$5.33	\$5.99

Cartridge Tape Club of America  
P.O. Box 5927, Clinton, Iowa 52737

Album Number	Indicate 8-T, C, or LP	Series Letter	Member's Price
_____	_____	_____	\$ _____
_____	_____	_____	\$ _____
_____	_____	_____	\$ _____
_____	_____	_____	\$ _____

Lifetime Membership Fee . . . \$5

8-Track Portable Player . . . . . (\$27.50) \$ \_\_\_\_\_

Here is my check for . . . . . (Total) \$ \_\_\_\_\_

Name \_\_\_\_\_

Address \_\_\_\_\_

City \_\_\_\_\_ State \_\_\_\_\_ Zip \_\_\_\_\_

2-778-4-20339

### SPECIAL BONUS OFFER

#### TRACK TAPE CARTRIDGE PLAYER

- Portable. Plays anywhere, anytime.
- Separate volume and tone controls.
- Plays on batteries or AC adapter.



ONLY \$2795  
Retail \$39.95

# Reader Design Page

This month's Reader Design, the Mach 1, was designed by Michael O'Connor of Syosset, New York. The Mach 1 is a high-flying sport model using unusual multiple fins. It flies well on B6-4 or C6-5 engines.

## PARTS LIST

Body Tube	9" ST-7
Nose Cone	BC-74
Engine Block	TR-7
Screw Eye	SE-10
12" Chute	CP-12
Shock Cord	SC-18
1/8" Balsa (Fins)	BFM-12

(All Parts Available From Centuri)

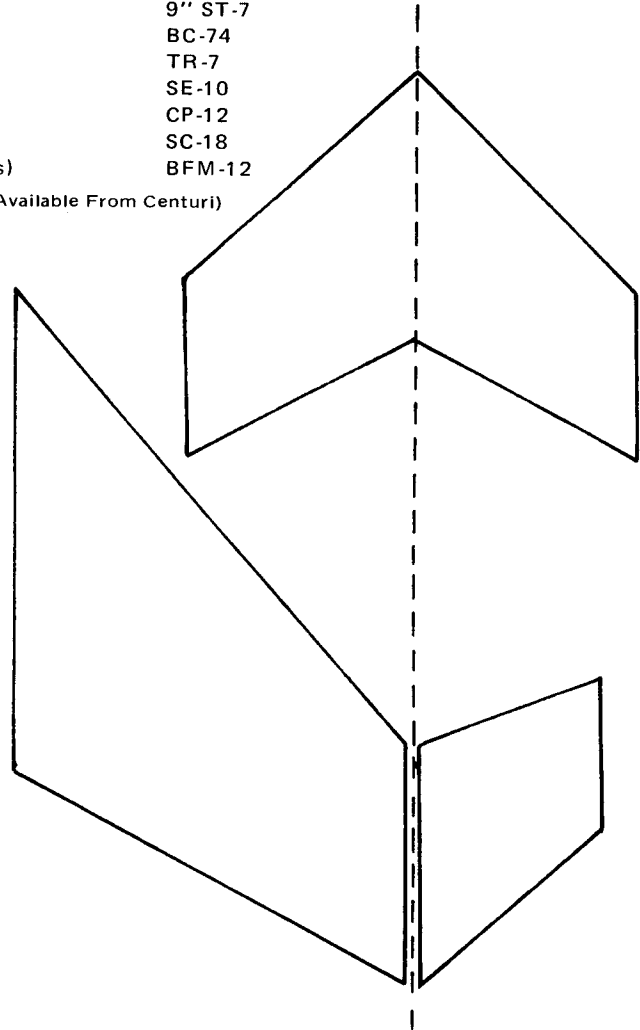
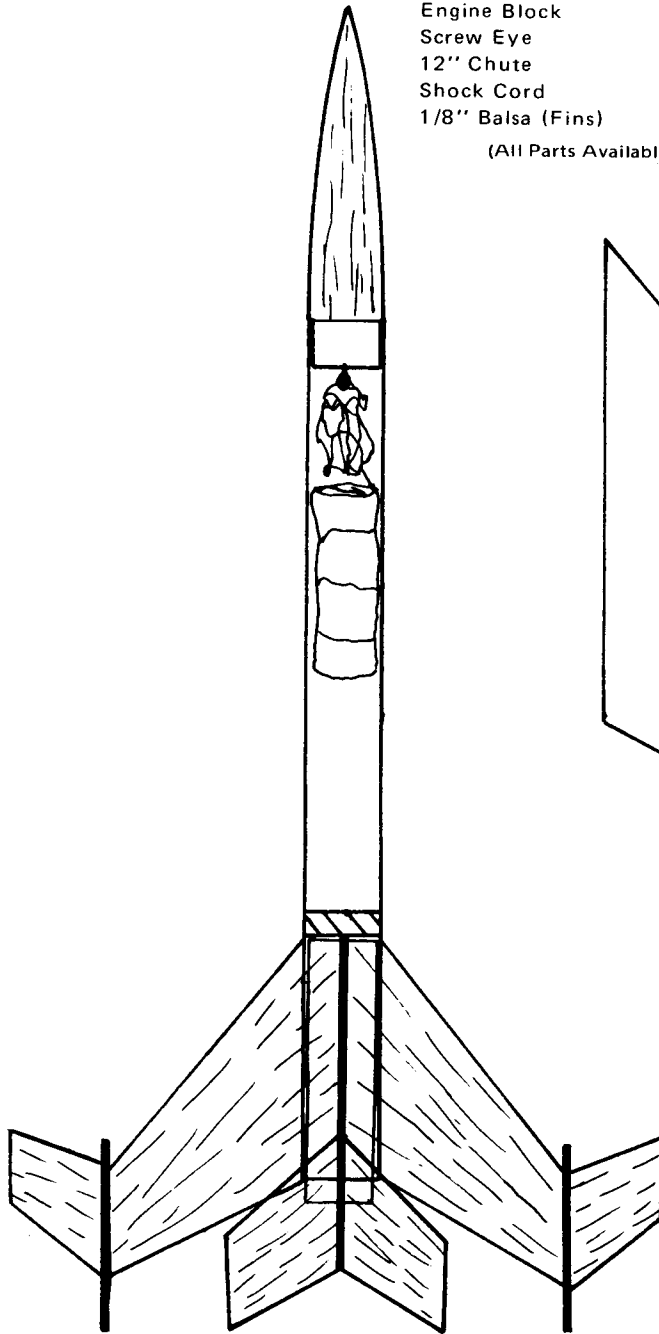

Each month **Model Rocketry** will award a \$5.00 prize for the best original rocket design submitted by a reader during the preceding month. To be eligible for this prize, entries should be carefully drawn in black ink on a single sheet of 8½ by 11 paper. Sufficient information should be contained in the drawing so that the rocket can be constructed without any additional information.

Submit entries to:  
Rocket Design  
Model Rocketry  
Box 214  
Boston, Mass., 02123



# A High-Performance Sparrow B/G Using Pre-Airfoiled Styrofoam Wings

## SKY SURFER II

*Designed by Joe Niederberger*

The *Sky Surfer II* is a high-performance, standard configuration boost/glider designed for competition in the Sparrow event. It uses a 3" chord foam wing to decrease the weight, allowing the *Sky Surfer II* to weigh in at 7 to 9 grams. With a wing area of 20 square inches, this B/G has a very light wing loading. This gives it a slow, almost floating, glide ideal for calm weather. If there are any thermals around, the *Sky Surfer II* will catch them and ascend slowly into the sky. Don't be surprised if you lose this one on a good flying day. With a A8-3 engine, mine has been turning in durations of two to three minutes consistently. That's not bad for an easy-to-build boost/glider.

### Construction

The first step in building the *Sky Surfer* is to cut the wing from a sheet of high-density styrofoam. Pre-airfoiled sheets of 3" chord styrofoam are available from D-B Industries (Box 2835, Dept. MR, Mansfield, Ohio 44906) for 75 cents. Use the "exact size" wing pattern in the drawing as a template, and cut the elliptical wing from the styrofoam using a sharp X-Acto knife. (Be sure to use "high density" styrofoam, the lightweight material used as packaging material is too light to withstand the boost stresses.)

Round the leading edge of the wing using 400 grit sandpaper. The wing should be tapered to a thickness of 1/32" at the trailing edge. To save on weight, a slight tapering of the thickness can be done from the root edge to the wingtip.

The root edge of each wing panel should be beveled by propping up the wingtip to 1/4" and sanding the root edge with the side of a sanding block. Repeat the same procedure with the second wing panel. This provides an angle of approximately 150 degrees between the wing axes, giving sufficient dihedral to assure roll stability during the glide phase.

Lay one wing flat on a work board. Add glue, Titebond or Ambroid Se-Cur-It, to the root edge. Prop up the second wing tip and press the root edges together. Set aside for several hours while the dihedral joint dries thoroughly.

The boom is cut from a piece of 1/4" X 1/2" balsa stock. The boom is constructed from balsa rather than spruce, since the extra strength of spruce is not necessary on a Sparrow glider. The small saving in weight gained by using balsa, as well as the foam wings, is what turns the *Sky Surfer* into a "floater." Again use the full size plans as a template, and cut out the boom with an X-Acto knife. Using fine sandpaper (220 to 320 grit) sand the boom to shape—rounding the lower edge of the forward section and sanding the section behind the wings to a "teardrop" shape. Do not sand the top of the forward section (where the pylon will be mounted) or the bottom of the rear section (where the stabilizer will be mounted).

Using a very sharp X-Acto knife cut the piece-X section out of the boom. Cut two balsa strips from a sheet of 1/16" thick hard balsa. Using Titebond or Se-Cur-It laminate these strips to the sides of the forward section of the boom. Be careful not to get any glue inside the piece-X cutout.

The stabilizer and rudder should be cut from 1/16" sheet balsa. Both sides should be sanded smooth using 400 grit sandpaper. The leading edge of both the rudder and stabilizer should be rounded.

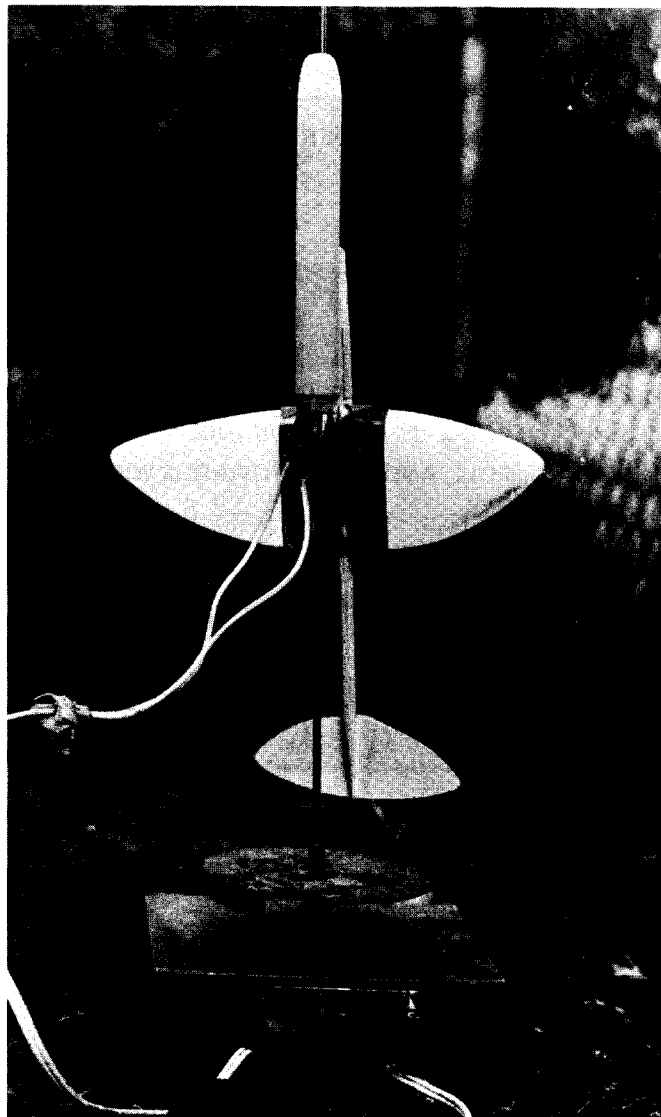

The "Sky Surfer II" is a lightweight, high-performance Sparrow boost/glider. To minimize weight styrofoam wings are used, turning this glider into a real "floater."

1/16" SHEET Balsa STRIPS LAMINATED TO SIDES OF BOOM.



BOOM -- CUT FROM Balsa STOCK 1/2" BY 1/4", TAPER AS SHOWN.

STYROFOAM WING SECTION -- CUT WING FROM 3" CHORD DB INDUSTRIES WING, AIR-FOIL, AND TAPER TOWARDS WING TIPS.



# *Sky Surfer II*

DESIGNED BY: JOE NIEDENBERGER

DRAWN BY: GEORGE J. FLYNN 5/20/71

HALF MIL ALUMINIZED MYLAR ATTACHED  
TO UPPER WING SURFACE  
WITH THIN LAYER  
OF EPOXY.

FRONT VIEW  
( $\frac{1}{2}$  size)

150°

STABILIZER -- CUT FROM 1/16"  
SHEET BALSA

RUDDER -- CUT FROM 1/16"  
SHEET BALSA

page  
24/25  
overlap

1/16" SHEET BALSAM STRIPS LAMINATED TO  
SIDES OF BOOM.

BOOM -- CUT FROM BALSAM STOCK 1/2" BY  
1/2", TAPER AS SHOWN.

STYROFOAM WING SECTION -- CUT WING  
FROM 3" CHORD DB INDUSTRIES WING, AIR-  
FOIL, AND TAPER TOWARDS WING TIPS.

HALF MIL ALUMINIZED MYLAR AP  
TO UPPER WING SURFACE WITH THIN  
OF EPOXY.

FRONT VIEW  
(1/2 size)

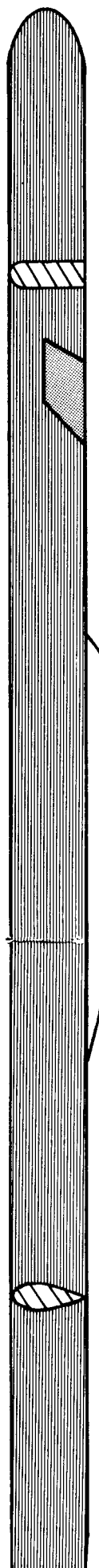
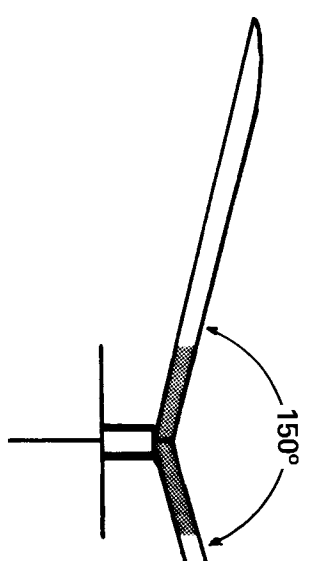

RUDDER -- CUT FROM 1/16" --

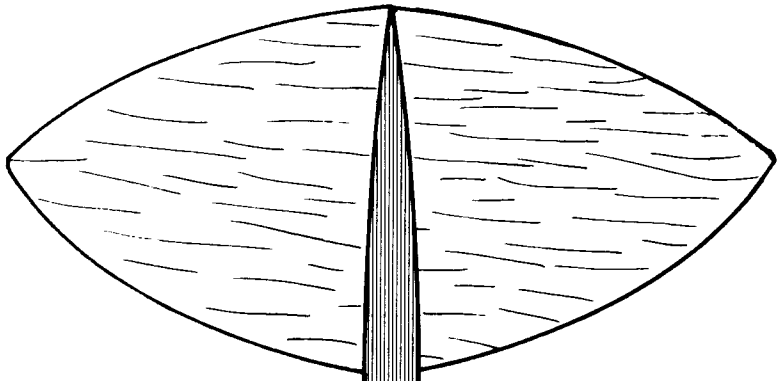

HALF MIL ALUMINIZED MYLAR ATTACHED TO UPPER WING SURFACE WITH THIN LAYER OF EPOXY.

FRONT VIEW  
(1/2 size)

page  
24/25  
overlap

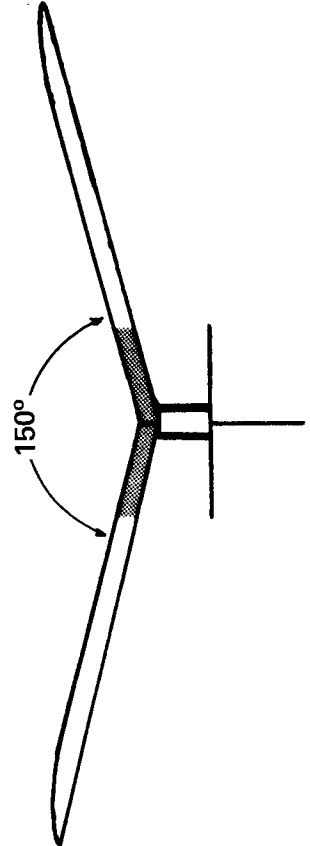

STABILIZER -- CUT FROM 1/16" SHEET BALSA

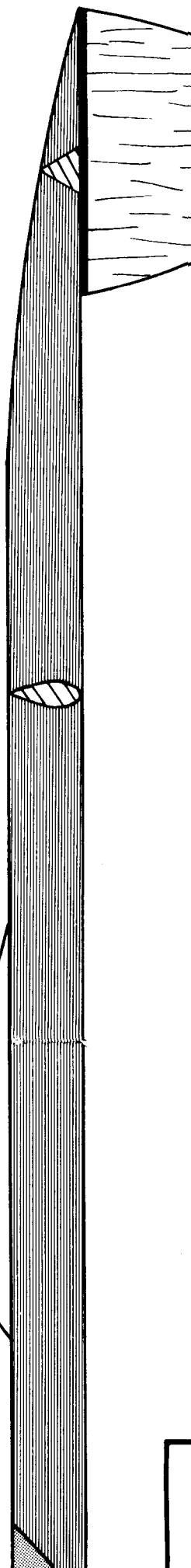

ATED TO

BY

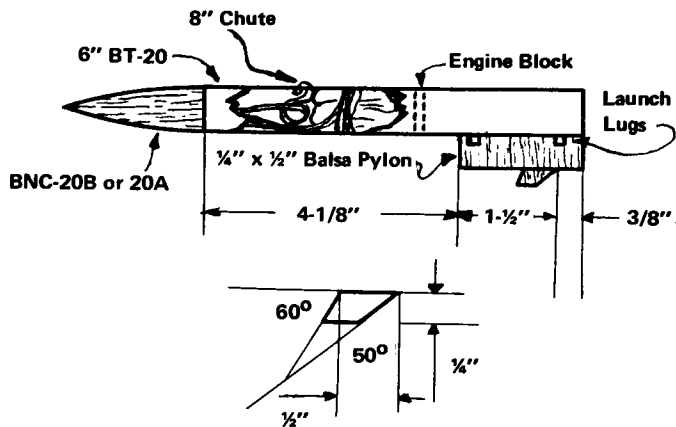

Any standard piece-X pod can be used on the Sky Surfer. Just be sure to use a pylon at least 1/2" high or you run the risk of burning the styrofoam wings.

The trailing edges should be tapered to 1/32" using a sanding block.

Glue the stabilizer to the bottom of the boom. Then glue the wing to the top of the boom, with the leading edge four inches back from the tip of the boom (as shown in the plans). When dry, glue the rudder to the underside of the stabilizer. Fillet the wing/body joint to increase strength.

#### Finishing the Sky Surfer

Actually the Sky Surfer requires very little finishing — sanding all the surfaces with 400 grit sandpaper before final assembly gives it a smooth finish. If you want, you can brush the surface of the balsa parts with clear dope (it's lighter than colored dope) thinned 50% with thinner. After the dope is dry, sand the surfaces again with 400 grit sandpaper. (Don't get any dope on the foam wings).

The only finishing really required is the aluminized mylar "blast deflector" on the center section of the wing. Cut a piece of one-half to one mil aluminized mylar to 3" by 2". Mix a batch of quick curing epoxy, such as Hobbyepoxy Formula 4, and apply a thin layer to the wing surface where the mylar is to be attached. Place the mylar over the epoxy, and run your finger over it until it is free from wrinkles.

The aluminized mylar looks pretty on the glider, but it's really the epoxy which protects the styrofoam from the exhaust. So be sure to use epoxy to adhere the mylar to the wings.

The pop-pod is built in the normal manner. A 6" length of BT-20 is cut on the CMR Body Tube Cutter. An engine block is glued in place, using a short A engine as a placement guide. The pylon, cut from 1/4" thick balsa and lightly sanded with 400 grit sandpaper, is glued into place at the rear of the body tube. A BNC-20B nose cone, hollowed to decrease the weight, is attached to the 8" recovery chute, a launch lug is added, and the pod is complete. Use a chute rather than a streamer, because there is less chance of a "Red Barron" with a chute.

Check the pod by slipping it into the "Piece-X" cutout on the boom. Hold the pod upside down, and if the glider does not slip off it is too tight. Sand the sides of the Piece-X until a good fit is obtained.

#### Glide Trimming

The Sky Surfer is trimmed in the same manner as other "standard configuration" boost/gliders. If it stalls in hand launching add a bit of clay trim weight to the nose; if it dives add trim weight to the tail.

You'll find that the Sky Surfer has a very wide range of trim positions which result in a good, stable glide. The only way to really trim this B/G is with a stopwatch and a half-dozen engines. Using 1/2A's to decrease the risk of lose, take your glider out to the field and time a flight. Observe and time the glide to notice the very slight tendency to stall or dive. Add a little trim weight to compensate, and fly the glider again. Check the time against the previous flight, and observe the results of the new trim. Make sure you conduct your trim session on a calm, thermal-less day or the results may be confusing.

Once you have the glider well trimmed, put an A8-3 in it and be prepared to have it fly away. The Sky Surfer has a very pleasing, slow glide, and will turn in good performances at your next contest.

**FLASHER MODULES**  
 READY TO USE — NOT A KIT  
 Styrofoam Case - Red or White Flashes  
 ONLY \$2.95 - less battery

**WALKIE TALKIES**  
 NO LICENSE REQUIRED  
 RANGE UP TO 12 MILES  
 Ideal for Telemetry or  
 Field Communications  
 Prices as low as \$14.95

**CASSETTE TAPE RECORDER**  
 Top Quality  
 Perfect for Recording Telemetry  
 or Club Meetings  
 Introductory Prices at \$29.95

We also carry —  
 Launch Alarm  
 Megaphones  
 Rocket Display Stands  
 Equipment Cases  
 and much more

For complete information  
 send 25 cents in coin  
 for Catalog

(will be refunded on first \$5.00 order)

To: **ARCHER INC**  
 Dept. C - 4181 Archer Ave.  
 Chicago, Ill. 60632

#### FULL SIZE PLANS AVAILABLE

In response to numerous requests from readers, Model Rocketry is making available full size plans of several Boost/Gliders published in issues of Model Rocketry which are now sold out. In future months we expect to announce the availability of scale plans from past issues, as well as reprints of the most popular articles.

Available for Immediate Shipment

**Bumble Bee B/G** — An elliptical wing Hornet B/G which has turned in contest performances of over two minutes. Full size plans 50 cents.

**Wasp B/G** — A lightweight Hornet or Sparrow B/G using a balsa boom. Popular contest performer. Full size plans 50 cents.

**Dove III Flop-Wing B/G** — Complete plans and instructions for the Dove III flop-wing. Designed as a Sparrow, this model can be scaled up to higher power events. Full size plans and complete instructions \$1.00

Order From: Model Rocketry, Box 214, Boston, MA. 02123

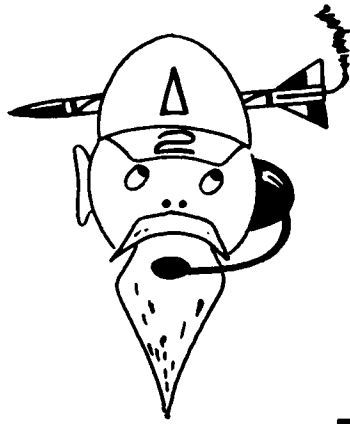

# The Old Rocketeer

by G. Harry Stine NAR#2

## Engines: 'Full Circle'

*(The following story is TRUE. No names have been changed to protect anything. It is history, and we model rocketeers have proved our point about safety, etc. so that we should no longer be ashamed of what has gone before).*

As Alan Shepard said, "It's been a long time, but we're finally here." I get the same feeling about model rocketry. It took 14 years, but we've come full circle. We have returned to the engine casing size we started with in model rocketry.

The very first model rocket engine I ever saw was on February 9, 1957. It was 12.7 millimeters in diameter and 57 millimeters long. (For those of you barbarians who have not converted to the logical, scientific metric system yet, that's 0.50 inches diameter . . . in the "olde English System" where there's some weird arrangement like 12 inches to the yard and 5280 yards to the mile . . . or something just as silly based on the length of the King's arm).

This model rocket engine was hand-loaded by Orville H. Carlisle of Norfolk, Nebraska, the inventor of the model rocket. It was a beautiful little rocket engine. With an internal diameter of 9.0 millimeters, it packed lots of propellant and plenty of "snort" (as Carlisle would put it). Carlisle loaded every one of these engines by hand in his basement using a modified arbor press. You don't need to know the details, because you now buy engines cheaper than you can make them. Carlisle taught me how to do it, and I would rather use factory-made engines than try to load my own.

When we set up Model Missiles, incorporated in Denver, Colorado in late 1957 with the avowed purpose of putting a model rocket in the hands of anyone who wanted to lay his hard-earned cash on the line for same, I had to set up mass production on the engines. Obviously, Carlisle could not continue to load them by hand in his basement at the rate of 150 per day.

Fortunately, Carlisle is also a successful and highly knowledgeable pyrotechnician as a hobby. He has all the books available about pyrotechnics, and could make nearly anything. He knew the pyrotechnics companies in the USA and was on speaking terms with the owners of most of them.

The only firm that expressed an interest in making the engines was the Brown Manufacturing Company and its subsidiary, the Zenith Fireworks Company. Carlisle knew and respected the late Mr. Lawrence W. Brown, the firm's owner, who was a duck hunter (like Carlisle), inventor of Chinese Checkers, and inventor of several types of model airplanes and model helicopters. Together, Carlisle and I went to see Brown in October 1957 to find out if he could make model rocket engines.

Brown allowed as how he could make them to our specs without much trouble. He had the cleanest operation for the handling of pyrotechnics and explosives that I had ever seen . . . and I had been educated in this sort of thing by the experts at White Sands Proving Ground.

"But I can make them for you quicker if I don't have to use your special-sized paper tube casing," and I can make a perfectly good model rocket engine using the tube I roll for my helicopter Buzz Bomb."

The Zenith Buzz Bomb was 0.69 inches in diameter, 2.75 inches long, had an aluminum wing on one side of it, and used a

nozzle drilled in the side. It was strictly a July 4th firework piece.

Brown loaded some Buzz Bomb tubes, drilled a nozzle in the end of the clay plug, and stuck them in some of our models. It worked!

Our static tests involved putting a motor nozzle-up on a spring postage scale and measuring duration with a stop watch. The bigger Brown engines would bottom a one-pound scale.

We said, "Fine," and placed an order for 10,000 engines. *Thus was the "standard" model rocket engine" size established!*

The standard casing became 18 millimeters in diameter and 70 millimeters long when we finally switched to metric system. It was all based on the size of the available tube rolled by Lawrence Brown.

On a hot day in July 1958, a young man with glasses and a crew-cut walked into my sweltering office at Model Missiles, Inc., at 1159 California Street, Denver, Colorado. "My name is Vernon Estes," he said. "I don't know who is making your model rockets for you, but I will make them better and cheaper." And he proceeded to do so.

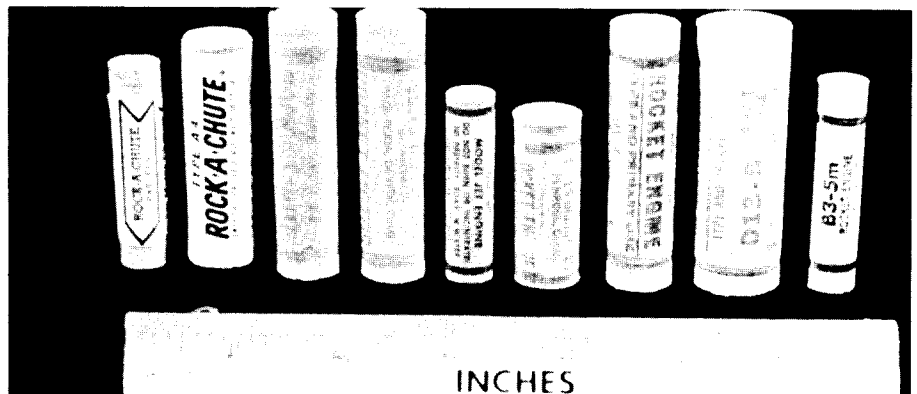
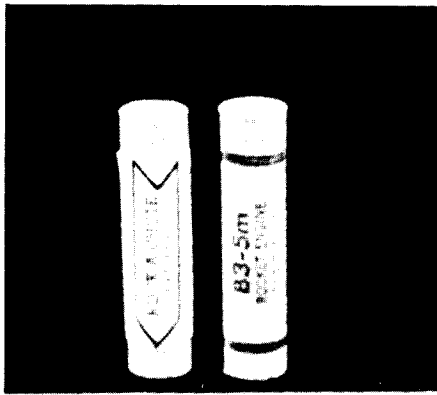

Photo by Stine

Here is the story of the development of the small rocket engine (up to Type D). Left to right, history marches forward. First, the 1957 hand-loaded Carlisle "Rock-A-Chute." Then the first MMI "Rock-A-Chute" made by Brown Manufacturing Company. Then an original MMI "Rock-A-Chute" made by Vernon Estes, followed by an early and identical Estes Enterprises engine of 1960. The next one is the small Uni-jet of 1965, followed by an Estes "shorty." Estes went to a thin-walled 18 mm casing next to produce his high-thrust B's and his C's, and finally even bigger for the D13 series. The latest is the MPC "Minijet" on the right end, a return to the small model rocket engine that got model rocketry off the pad in the first place.



INCHES

The old and the new...without much difference in size! On the left, a 1957 hand-loaded Carlisle "Rock-A-Chute" Type 4-4-1 model rocket engine. On the right is a 1971 MPC "Minijet" Type B3-5m model rocket engine. Both are within 0.5mm of being the same diameter (Carlisle is 12.7 mm, MPC is 13.0 mm), and both are 57 mm long.

Vern set up shop in an unheated corrugated shed with one side open. It was behind his house at 5505 N. Tejon Street in Denver. There, on an old lathe that didn't have a starting capacitor on the motor, with an old drill press, and with a tremendous amount of ingenuity and perseverance, Vern Estes built "Mable"—the automated model rocket engine fabrication machine.

Because Vern's engines would have to be compatible with the existing engine mounts of the MMI model rockets, he had to make his engines the same size as those supplied by Brown. Vern did not roll his own tubes; he bought them factory-rolled to the same

dimensions as the Brown engine casing: 0.960" in diameter and 2.75" long.

In the early afternoon of a cold, blustery day, January 15, 1959, the first engine of the first production run popped out of Mable. I still have it.

But Mable could cough up Model rocket engines every 5.5 seconds. She could generate lots and lots of rocket engines! Soon, Estes was up to his arm pits in model rocket engines, more than MMI could absorb and sell. So Vern went into the mail order model rocket business.

In 1964, there was a brief return to the "half-inch engine", as we tended to call it. George Molson of Uni-Jet Company started to produce a little model rocket engine that was 0.500" in diameter and 2.25" long. They were as 1/2A.5-2 (metric equivalent 1/2A2-2), 1/2A.5-3 (1/2A2-3), 1/2A.5-0 (1/2A2-0) and 1/2A1-3 (1/2A4-4). These engines were NAR-certified in late 1964. However, George Molson used a very different and highly unusual solid propellant, and the reliability of his Uni-jet engines suffered as a result. The thrust time curve was dependent upon the number of days that had elapsed since the engine had been made. At a certain time after manufacture, the thrust-time spike at ignition became extremely high . . . and the nozzle left the party. Sometimes the paper casing ended up looking like a peeled banana. Molson could not solve the problem, and the Uni-jets left the market late in 1965. Yet, they became a legend because of their small size.

About the same time, Vern Estes started marketing his "shorty" engines of 18 mm. diameter which are still available today. This was an attempt to eliminate as much excess weight as possible, since a 1/2A engine doesn't come near to filling up a standard sized casing.

In the meantime, the entire world was busily converting to the USA's 18 mm. standard engine casing size. The Czechs redesigned their famous Adast engine from 21 mm. diameter to 18 mm. diameter. The only

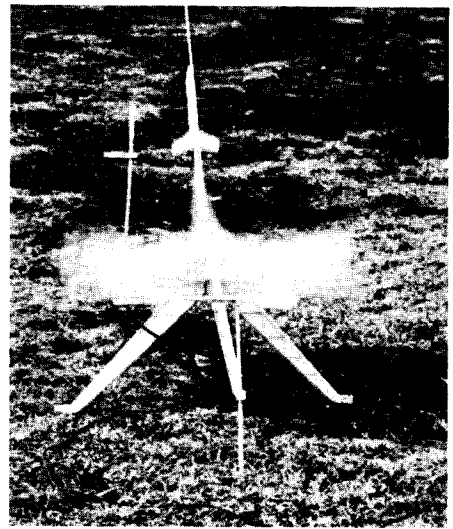

They really work! A new Minijet boosts the Pipsqueek on its first public flight. The model broke through the clouds at the April 1971 MIT Convention.

hold-out was Flight Systems, Inc. with their 21 mm. engine series.

And I kept bugging the manufacturers to make the "half-inch engine." George Roos of FSI, more as a joke than anything else, I believe, whopped up some engines 9 mm. in diameter, but these "Freeeps" almost seem too small. FSI never produced these engines because they cost about as much to make as a standard engine size.

When Mike Bergenske of Model Rocket Industries set up to make model rocket engines in Wisconsin, he also began by making the "standard" 18 x 70 mm. engine size. It was handy. MRI engines would fit into Estes and Centuri rockets, and Estes engines would fit into everybody's models. Then MRI was purchased by Model Products Corporation and became MPC. But Mike Bergenske never forgot about the "half-inch engine" or the old Carlisle engines that I showed him.

He began experimenting with little engines, and had some prototypes available in December 1970. In late January 1971, MPC made the decision to go ahead full-steam with the little engines ("Minijets") and a full line of small model rockets ("Minirocs") to use them.

I was requested to design the models, the Minirocs. It was a 14-year dream come true at last. Here is what I wanted to do in the first place back in 1957! Now, I had 14 years of accumulated experience and an established technology to work with, however. And I believe the Minirocs are greatly superior to anything that I could have done 14 years ago. Because I was more experienced I put a great deal more into the designs.

For example, the entire line-up of the first 6 Miniroc models were designed *on-the-drawing board*. They had to be! We did not have flight test Minijet engines until late March, 1971. The weather was so lousy in Connecticut that I could not have done any testing anyway. Mike had flown some test models in Madison, Wisconsin and we had flown some in Mt. Clemens, Mich. just to see how the Minijet engines performed in flight. But the first Miniroc into the air was the MPC Tarus-1 design which went aloft



Harry Stine preps the new Delta Katt for its first public flight with the new MPC Minijet engines. Mike Bergenske, who designed the Minijet engines, looks on. The Delta Katt turned in a 35 second flight on an A engine.



in New Canaan, Conn. on Sunday, March 14, 1971. It was immediately seized by a rocket-eating tree.

The Miniroc Super/Star and the Pip-squeak actually flew under power for the first time at the M.I.T. Convention in full public view. The calculations said they had to fly, and they did. The confidence I had was not in myself but in the Barrowman C.P. calculations and the Malewicki altitude predictions. I beg to report that if you use them properly, they will produce results.

The Delta Katt B/G was something else. I'll have a complete article about it in a forthcoming issue of MRm. It was also designed on the drawing board using NASA wind tunnel data and a knowledge of general

aerodynamics. The first prototype flew like a brick before I discovered the slight but simple mistake that I had made. The second prototype glided fine, but I did not have engines to boost it. The first boosted flight took place on March 28, 1971 in New Canaan with a dash-zero booster engine, which was the only Minijet I had an hand. It boosted OK.

The first full boost-coast-glide flight made by a Delta Katt took place at the M.I.T. convention in full view of a couple hundred model rocketeers. 'Swelp me, it's true! Everything told me it had to work . . . and the numbers didn't lie!

So I am personally delighted by the new MPC Minijets. They've turned model rocketry

around from bigger and bigger to smaller and smaller. Engine weight has been cut by nearly 45%. Drag due to frontal area has been cut by nearly 36%. I have a Heller "Veronique" plastic kit that I can now fly in Plastic model events. If you put some extra clear plastic fins on, you can convert the Revel "Mercury-Redstone" kit to fly, too. (I know because I converted one to fly with the Unijets in 1965.) Competition is going to become a whole new game now. Design Efficiency, Drag Efficiency, Boost/Glide, Rocket Glider, and Altitude events are going to see a great change.

As I said before, It's been a long time, but we got back to the small engines we started with.

## New Product Notes

Edmund Scientific has introduced a new catalog containing many items of interest to model rocketeers. Ultra thin aluminized chute material (approximately 1/4 mil), weighing only an ounce for a 56" X 84" sheet and selling for \$2.00 postpaid as item no. 60,636. For egglofting there is "Fantastic Foam," foam in a spray can which can be used on the range to cushion the inside of egg capsules. Fantastic Foam sells for \$4.75 for 2 twelve ounce cans, enough for quite a few egg capsules, as no. 71,327. Rocketeers interested in "balloon launching" will find the Helium Balloon Kit (no. 71,289) quite useful. The kit contains 21 liters of Helium in a spray can as well as 25 small balloons for \$3.00 postpaid. For aerial photography, Edmund lens no. 30,570, a 67 mm achromatic lens, can be used for Camrock conversions. The lens is priced at \$3.00.

For clubs the new Edmund catalog contains a number of interesting items of range equipment. An inexpensive scale, calibrated in both ounces and grams, weighing rockets up to 16 ounces (450 grams) sells for \$6.65 as no. 90,053. An inexpensive stopwatch, featuring separate stop, start, and reset buttons, sells for \$15.00 as no. 41,359. For scale judging (or building) Edmund stocks two precision calipers. The economy version, priced at only \$3.00, reads to 1/128" or 0.1

mm (stock no. 40,598). A more expensive Dial Reading Caliper, accurate to 0.05 mm, sells for \$21.00 as no. 60,509.

Edmund also sells the Vashon Valkyrie I rocket (no. 71,182) for \$15.95. Two cans of extra propellant sell for \$4.00 (no. P-71, 192.).

Rocketeers will find many other items of interest in the new Edmund catalog. Write for free catalog "MK" from Edmund Scientific, Dept. MK, 300 Edscorp Bldg., Barrington NJ.

A new National Aeronautics and Space Administration educational publication entitled, "Apollo 14 - Science at Fra Mauro" (NASA EP-91) is now on sale at the United States Government Printing Office, Washington, DC at \$1.25 per copy. The 10,000-word booklet tells the story of the third manned lunar mission of Astronauts Alan B. Shepard Jr., Edgar D. Mitchel and Stuart A. Roosa, Jan. 31 Feb. 9, 1971. Of its 58 photographs, 42 are in color and include many taken on the Fra Mauro landing site during the Moon walks. The publication was produced by the NASA Office of Public Affairs. The author, Walter Froelich, is a science writer with the United States Information Agency in Washington.

"Science at Fra Mauro" is the fifth color

illustrated booklet on the Apollo program on sale at the Government Printing Office. Others are:

"In this Decade/Mission to the Moon" (NASA EP-71), which outlines the complex steps of manned Apollo 7, 8, 9 and 10. missions which led up to the first manned lunar landing; 46 pages, \$1.25 per copy.

"Log of Apollo 11" (NASA EP-72), documents the first landing on the Moon, which has been called the greatest voyage in the history of mankind; 12 pages, 35 cents per copy.

"Apollo 12 - A new Vista for Lunar Science" (NASA-EP74), tells the scientific significance of the second Moon landing; 24 pages, 65 cents per copy.

"Apollo 13 - Houston, We've got a problem" (NASA EP-76), documents Apollo 13's oxygen tank rupture which prevented a lunar landing and tells how the crew returned to Earth safely in an emergency mode; 25 pages, 75 cents per copy.

Orders for the publications must include payment in check or money order to the Superintendent of Documents, U.S. Government Printing Office, Washington, DC 20402. Postage stamps cannot be accepted as payment, but all prices stated include mailing.

Competition Model Rockets has introduced a new beginners kit - the Start. The kit features pre-cut balsa fins and a plastic nose cone. This high-performance kit, using streamer recovery, is designed as a transition to the competition kits by CMR. The Start is priced at \$1.00.

... THE FIRST IN A SERIES OF TECHNICAL REPORTS FOR ADVANCED ROCKETEERS ...

# FUNDAMENTALS OF DYNAMIC STABILITY

BY GORDON K. MANDELL

32 PAGES, ILLUSTRATED

ONLY \$2.50 PPD.

ORDER FROM: TECH REPORT, MRm, BOX 214, ASTOR ST., BOSTON, MA 02123

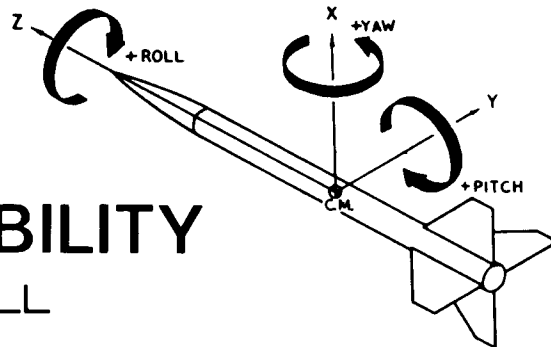

# TECHNICAL REPORT

## Simple Analytic Approximations to Model Rocket Engine Thrust-Time Curves

BY S. W. BOWEN

A recent article by Manning Butterworth<sup>1</sup> gave an interesting formula for an analytic representation of the model rocket thrust-time curve suitable for computer evaluation. Unfortunately his final result has six arbitrary constants which are rather difficult to determine for a given engine, even if one has a very complete thrust-time curve. A somewhat simpler approach that produces reasonably accurate thrust-time curves and has proven particularly convenient for large numbers of such computer calculations is given below. These formulas use a minimum number of constants which are easily calculated in terms of the values readily available from the typical model rocket catalog.

For any given engine, the constants conveniently available are

- (a) Total impulse  $I = \int_0^{t_B} T(t) dt$ ,
- (b) Average thrust  $T_0 = I/t_B$ ,
- (c) Burn time  $t_B = I/T_0$ ,
- (d) Peak thrust  $T_1$ ,
- (e) Time  $t_1$  at which the peak thrust occurs.

For both the series I and series II engines, the thrust-time curves are idealized as a series of straight lines as shown in figure 1.

The series II engine gives a particularly simple result since there are only two such curves. It can be easily shown that,

$$T(t) = \frac{T_1}{t_1} t \quad 0 < t \leq t_1 \quad (1)$$

and

$$T(t) = T_1 \frac{t_B - t}{t_B - t_1} \quad t_1 < t < t_B \quad (2)$$

For both series  $T(t) = 0$  when  $t > t_B$ .

To relate  $T_1$  and  $T_0$  we recall that the total impulse  $I$  is just equal to the area under the  $T(t)$  versus  $t$  curve. The result of this calculation for the series II engine gives:

$$T_1 = 2 T_0 \quad (3)$$

The series I engine requires three different straight lines and is correspondingly more complicated. For times less than  $t_1$ , we have:

$$T(t) = \frac{T_1}{t_1} t \quad 0 < t \leq t_1 \quad (4)$$

We assume the slope of the curve between  $t_1$  and  $t^*$  is the negative of the slope in Equation 4. We need to determine the time  $t^*$  at which plateau begins and the constant plateau thrust value  $T^*$ .

By equating the area under the  $T(t)$  vs.  $t$  curve to the known value of  $I = T_0 t_B$ , the values of  $T^*$  and  $t^*$  can be found. The results of this procedure follow.

Define the nondimensional values

$$s = t_1 / t_B \quad (5)$$

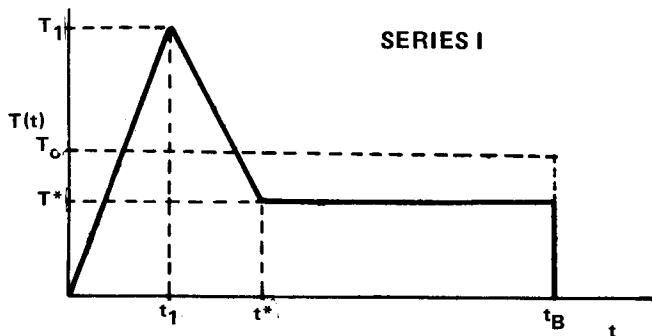

$$r = T_1 / T_0 \quad (6)$$

then calculate

$$m = \frac{s}{(2s-1) + \sqrt{(1-2s)^2 - 2s(s-\frac{1}{r})}} \quad (7)$$

The plateau thrust is given by

$$T^* = \frac{T_0}{(m-2 + \frac{1}{2m}) s + 1} \quad (8)$$

and the time at which the plateau begins is

$$t^* = (2 - \frac{1}{m}) t_1 \quad (9)$$

thus

$$T(t) = m T^* (2 - t/t_1) \quad , t_1 < t < t^* \quad (10)$$

and

$$T(t) = T^* \quad , t^* \leq t < t_B \quad (11)$$

The parameter  $m$  given by Equation 7 is:

$$m = T_1 / T^* \quad (12)$$

i. e., the peak to plateau thrust ratio, while  $r$  given by Equation 6 is peak thrust to mean thrust ratio. For Series I engines,  $T(t)$  is therefore given by Equations 4, 10, and 11.

The formulas given above are quite simple and straightforward to program for computer evaluation in essentially the order presented here.

Typical catalog values for an Estes B4 (Series) motor are:

$$T_0 = 4.0 \text{ newton}$$

$$t_b = 1.25 \text{ sec}$$

$$T_1 = 13.3 \text{ newton}$$

$$t_1 = .20 \text{ sec}$$

Then  $s = .160$ ,  $r = 3.33$  and  $m = 4.946$ . The value of  $t^* = .3595$  sec and  $T^* = 2.689$  newton.

### REFERENCE

1. Manning Butterworth, "An Analytic Representation of Model Rocket Thrust-Time Curves," *Model Rocketry*, Vol. III, No. 6 March 1971, page 37.

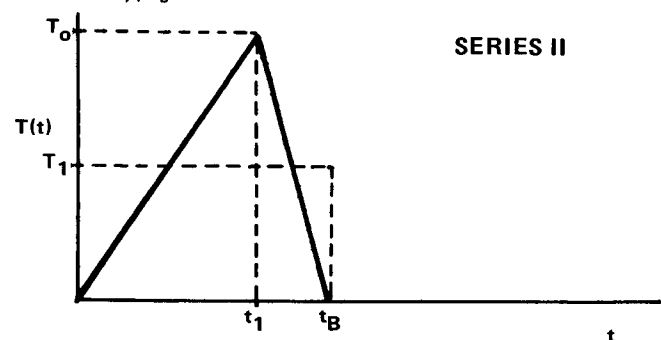

Figure 1: Idealized thrust-time curves for series I and II engines.

# 1971 MIT Technical Model Rocket Convention

BY GEORGE FLYNN

The 1971 MIT Technical Convention, held over the April 2-4 weekend, had even more emphasis on technical topics than at previous Conventions. The theme of the gathering was "techniques of model rocket engineering," and over 100 rocketeers from 10 states participated in the exchange of information on current research projects and discussions of high-performance contest design. These sessions on competition design were generally oriented towards new techniques (Radio Control, use of "Flop-Wings," and other new design innovations).

Lack of a suitable launch field in the Cambridge area forced cancellation of the launch, placing even more emphasis on the technical topics. As an added innovation, to encourage the exchange of information between technically minded rocketeers, each rocketeer presenting a "technical report" was required to submit a 2 to 4 page summary which was published in a 50 page collection of *Proceedings*.\*

Following a brief opening session, the Convention got down to the technical business with a series of Discussion Groups. In a session on "Basic Boost/Glider Design" Bern-

ard Biales explained the historical development of the boost/glider and examined how the currently accepted "design criteria" have come into being. The first B/G's were the "flying wings" such as the Estes Space Plane. These were developed by extending the fins on a standard rocket until they were large enough to be wings, and adding elevons (which were actuated by engine ejection) to provide glide trim. These early B/G's were of the rear engine type, a logical development from the standard rocket. As competition gliders they have two drawbacks: 1) accurate elevon trim is required, and 2) they have high drag in the glide configuration. Then came the Renger "Sky-Slash." This first of the front-engine B/G's used, in its original version, a "flip-up" elevator and a fixed forward pod. Still later the pop-pod was developed to lessen weight and drag during glide. The swept back wings of the Sky Slash were soon replaced with straight wings since, as Bernard observed, "there isn't any reason to sweep back, and there are a lot of reasons not to do it." Basically, the swept-back wing has a greater tendency to flutter and is structurally weaker than the equivalent straight wing. Thus evolution towards a consistently winning competition boost/glider has resulted in the selection of a pop-pod, straight wing B/G very similar to the "hand launch glider" designs which have evolved in model airplanes.

Convention Chairman Trip Barber led a

group on "Advanced Propulsion Topics" which started off with a description of the characteristics of black powder and ammonium perchlorate, the two common model rocket propellants. He also discussed the design and construction of static test stands useful for model rocket testing. On the experimental side, Carl Guernsey discussed his recent thrust augmentation experiments. Carl has been tandeming a spent engine behind a live engine, and injecting liquid freon into the rear engine, increasing the overall efficiency. As yet Carl's experiments are not complete, but his results indicate that a significant increase in total impulse is obtained by freon injection.

In another Friday night session Bob Parks discussed "High-Performance Design." He suggested the use of turbulators, small bumps to cause a transition from laminar to turbulent airflow, just above the base of the body to obtain better airflow into the "wake" behind the rocket. In addition, he pointed out that studies in higher Reynolds number regions indicate that a squared-off trailing edge gives a greater pitching moment (and thus higher corrective mo-

\* Copies of the *Proceedings of the 1971 MIT Technical Model Rocket Convention* are available for \$2.00 per copy from the MIT Model Rocket Society, P.O. Box 110, MIT Branch PO, Cambridge, MA 02139.



Frank Bittinger explains his MODROC 8 and 9 programs which allow altitude prediction including variable mass and supersonic drag coefficient.

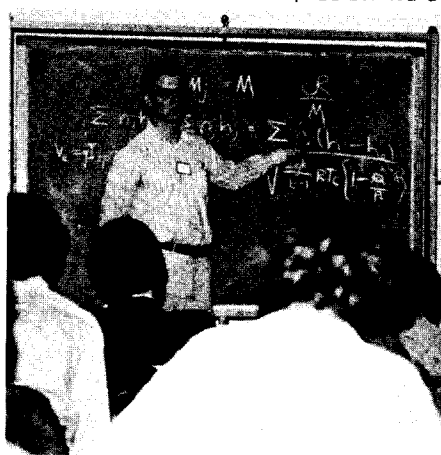

Convention Chairman Trip Barber explains the method used to calculate the internal combustion temperature for his report on model rocket engine burning characteristics.



Howard Kuhn, 1969 Senior National Champion, addresses the Convention on Rocket/Glider design and performance.

ment) than the tapered trailing edge currently in use. (The squared-off trailing edge is employed on many modern sounding rockets such as the Tomahawk.)

On Saturday morning the rocketeers were taken on a tour of the MIT facilities available for rocket experimentation. Several tours were run, and only about 15 rocketeers were taken on each one to allow time for questions to be answered.

The first stop was a TR-20 analog computer on which Tom Milkie simulated the flight of a model rocket. The computer was programmed to show all effects of stability, thrust cutoff, oscillations, and drag—each of which could be varied by twisting a few knobs. Unfortunately the computer developed a few “bugs” at times, and the simulated rocket would go unstable or the engine thrust would not cut off.

The next stop on the tour was the MIT wind tunnel facility. Gordon Mandell showed the operation of the low turbulence

tunnel (built several years ago) and an MIT tunnel currently being used to test helicopter blades.

The tour concluded with a demonstration of the rocket engine test chamber. The facility is currently set up to test engines in the 0 to 20 pound thrust category, though it was originally built for much larger engines. Thus the one inch thick steel wall separating the engine from the operator seems a bit excessive. The engines are fired remotely by an operator outside the test cell, viewing is through two thick glass ports in one wall, and thrust-time readout is on a chart recorder outside the cell.

Following the tour Col. Howard Kuhn drew on his competition experience to discuss “Competition Design and Strategy.” Since his Saturday evening lecture was scheduled on the subject of rocket/glider design, this afternoon lecture was much more general. He offered a few “common sense” guidelines which only the successful modelers

seem to follow. For example, he suggests building a different model for each event and designing the bird with the particular event in mind. Don't try to fly your Egg-loft model in Parachute Duration if you want to win *consistently!* Though a poorly designed bird may occasionally be victorious you'll find that the rocketeers who win in most of the contests they enter are the careful and meticulous designers.

G. Harry Stine of MPC then led the Convention participants out to an adjacent field to demonstrate the new Minijets—half inch diameter engines from MPC—and the Minirocs—a line of six new miniature rockets designed to be flown with the Minijets. There was a low lying cloud layer, and the B-powered *Pipsqueek* went right on through it and out of sight. The *Delta-Katt*, a Miniroc boost/glider still in the experimental stage back in April, put on quite a show turning in 35 seconds on A-power before it went out of sight behind a building.

# Abstracts of Technical Reports

## Presented at the 1971 MIT Convention

### **Model Rocket Altitude Prediction Using Thrust, Weight, and Drag Coefficient** by Frank L. Bittinger.

The “MODROC8” computer program provides for the use of variable thrust, weight, and drag coefficient in calculating model rocket altitude performance. This allows analysis of models whose velocities approach the speed of sound, and rockets employing engines whose propellant weight is a large fraction of the model's total weight. The “Modroc 9” program is similar, but incorporates provisions for multi-stage analysis.

### **A Model Rocket Automatic Launch System** by Martin Kriegsman

A unijunction transistor timing circuit is used to operate a five lamp sequential display, and to activate the firing circuit after the fifth lamp is lit. The automatic countdown device, employing an abort switch for added safety, was designed to add realism to range operations.

### **Computer Applications to Model Rocket Design and Evaluation** by E. Bergmann and D. Ruvin

The program, run on an IBM 360/50, employs a pattern search technique to consider different combinations of model rocket dimensions (fin size, length, etc.) to optimize the rocket's performance while assuring static stability.

### **Technical Note on Altitude Theory** by Pat Miller

The successive substitution technique is used to obtain a solution to the Malewicky approximation for model rocket altitude performance.

### **Theoretical Investigation of Model Rocket Engine Internal Ballistics** by Trip Barber

A self consistent set of theoretical values for the internal ballistic quantities (chamber temperature, chamber pressure, etc.) which are also consistent with the observed values for those quantities which are directly observable was derived. This leads to predictions for the internal ballistic quantities for a typical C6-5 Estes engine.

### **A New Model Rocket Aerial Camera** by Frank Osborn

Using a “self-timer,” of the type used in photography, an aerial camera allowing a single photograph to be taken at a pre-determined time (independent of the ejection charge time) was developed.

### **The Effects of Acceleration on Trained and Untrained Mice** by Thomas Hendrickson

A six month test series on 14 mice, seven subjected to spin and centrifuge training and a control group of seven untrained mice, indicated that the trained mice reacted better and recovered more quickly after flights in model rockets.

### **Separate Engine Staging** by Joseph Sarkis

A series of experiments were conducted to establish that standard

engines could be multi-staged with a distance of 5½ inches between the top of the first engine and the nozzle of the second. A 3 inch air gap followed by 3½ inches of brass tubing was used to conduct the ejection gasses.

### **Computer Applications in Designing Model Rockets** by S. McManamin and T. Martin

A computer program, written in BASIC, was developed to allow computer selection of the optimal configuration by examining a large number of alternative designs. Parameters considered are length, nose length, fin root chord, fin tip chord, fin width, and fin diagonal.

### **Rocket Trajectory Simulation Inclusive of Variant Parameters** by R. Schnidler and J. Bennett

A computer program to eliminate the basic simplifying assumptions of the Malewicky altitude calculation technique was developed. This program uses successive linear approximations to the thrust-time curve, variable mass, and air density as a function of altitude, as well as moist air changes and wind correction factors.

### **Wind Tunnel Testing of Thin Flapped Airfoils** by Guppy

An airfoil using four hinged flap sections was tested at a Reynolds Number of 53,000 in a 12” low turbulence wind tunnel. Measurement of the lift and drag coefficients and the pitching moment for different flap deployments indicated that a location of camber in the forward third of the airfoil was most efficient. Using two flaps, an efficient and practical arrangement is with the one in front hinged at 30 degrees and the one in the rear hinged at about 65 degrees.

### **Thrust Augmentation by Freon Injection** by Carl Guernsey

A spent engine casing, epoxied to the live casing, was used as an injection chamber to add liquid Freon to the exhaust. By injection of liquid Freon, the performance (total impulse) of a C—engine was increased by 50 to 130%. It was also indicated that there is an optional Freon flow rate for maximum thrust increase.

### **An Investigation of the Closed Breech Launching System** by Alan Stolzenberg

Using a Foxmitter accelerator six test vehicles were launched. Comparison of the data from three rockets launched from the closed breech launcher and three rod launched “controls” indicated a 64% increase in burnout velocity and a 110% increase in burnout altitude using a breech launcher of approximately one inch diameter.

### **The Proceedings of the 1971 MIT Technical Model Rocket Convention**

A fifty page booklet including two to four page summaries of all reports presented, is available for \$2.00 from the MIT Model Rocket Society, Box 110, MIT Branch Post Office, Cambridge, MA. 02139. Addressed of all authors of reports are included in this booklet.

The prime attraction Saturday afternoon was the presentation of R&D reports. Unlike the discussion groups where group leaders were selected by the Convention Committee, all rocketeers attending the Convention were invited to present reports on their current R&D activities. A total of 14 reports on topics as diverse as "The Effects of Rocket Flight on Trained and Untrained Mice" and "A Theoretical Investigation of Model Rocket Engine Internal Ballistics" were presented. To encourage further distribution of these reports, summaries were collected, printed, and made available to Convention participants. (Brief abstracts of the summaries are included with this article.) There was a noticeable emphasis on computer programming among the R&D reports, with four reports concerning various methods of flight simulation or computer design of model rockets.

Frank Osborn described an aerial camera which he developed in order to allow use of special infra-red photographic films. The shutter system was from an Estes Camroc, but the lens was salvaged from an old (broken) camera. A small "self-timer," of the type sold in photo stores to allow a photographer to include himself in the picture, was used to trigger the shutter. This allows pictures to be taken at liftoff, during boost, coast, or descent, rather than being dependent on the ejection charge. (A similar system could be incorporated on the Estes Camroc by using a "self-timer" to trigger the shutter.)

Guppy presented the data obtained in a series of wind tunnel tests of "flapped" boost/glider wings. The wing, which uses a hinged flap bent flat during boost and released at ejection to form an undercamber, was tested in a 12" low-turbulence wind tunnel at MIT. Measurements of the lift and drag coefficients and the pitching moment allowed evaluation of the best hinge point. His data indicated that a location of camber in the forward third of the airfoil produced more lift, less drag, and less center of pressure travel than the same degree of camber in the rear third of the wing. Unfortunately, Guppy indicates that it is impractical to design a wing with the flap in this location. He determined that "a more efficient and practical arrangement was the use of two flaps, one in the front (hinged about 30%), and one in the rear (hinged at about 65%). In general, the forward camber seemed to be most important in determining the center of pressure travel while the use of rear camber increased the lift somewhat."

Another practical experimental project was the investigation of "Thrust Augmentation by Freon Injection" done by Carl Guernsey. Injecting liquid freon into a secondary chamber, Carl found an increase of 50% to 130% in total impulse over non-injected engines. His static test stand set-up is one which can be duplicated inexpensively by any rocketeer who is willing to spend a bit of time evaluating the data. The engine is mounted upside down on a postal scale, and the firing is photographed using the highest speed setting on a home movie camera. On most cameras speeds of 32 to 64 frames per second are available. When the film is processed the thrust is read off each frame by noting the reading on the scale



Bob Mullane (right) and Sven Englund preside over a discussion of "Pink Book Revisions." The revision committee held sessions at the Pittsburgh and MIT Conventions to accept suggestions for revision and updating of the contest rules.

and graphing as a function of time. Results aren't too accurate, since the damping on a postal scale isn't sufficient, but it does provide a good way to compare a normal engine with a freon injected one.

Howard Kuhn, 1969 Senior National Champion, addressed the Saturday night banquet on the topic of "Variable Geometry Rocket/Glider Design." Since the rocket/glider event was only introduced a year ago, "there can't have been too much research done on it," he said. But there is general agreement that only two basic approaches are available: 1) to move the CP, or 2) to move the CG. "All approaches to rocket/glider have some kind of mechanism to actuate the glider. No matter how you build it, it is going to be difficult."

"The rocket/gliders I am going to describe tonight," he continued, "are the ones which survived a test program and are worthy of further development." The first, which "offers the greatest potential for B/G and R/G since the wing area is cut in half and it has a symmetrical airfoil during boost, is the "flop-wing" (see *MRM* August and September 1970). The flop-wing is about the simplest variable geometry B/G or R/G you can build," since each wing panel merely is cut in the center, hinged, and folded under. The strength of a "flop-wing" during boost is greater than a normal wing, since it is doubled over.

The "swing-wing" design allows the center of pressure to be moved back during boost—resulting in a more stable flight. Here the wing panels are mounted on two pivots, and are "swung" back against the fuselage during boost. A frequent problem with swing-wings is an inherent weakness at the pivot.

Other designs mentioned in Col. Kuhn's discussion included the "flop-swing-wing" in which the flop wing is hinged at a 45° angle to the fuselage axis, and the outer portion is



Guppy explains his wind tunnel experiments measuring the lift and drag of "thin flapped airfoils," of the type used on flop-flap-wing boost/gliders. His results indicated that the most efficient flap location was one-third of the way back from the leading edge. This hinge line gave more lift and less drag than the other arrangements tested.

folded back parallel to the fuselage (as in a swing-wing). A Manta-type "fold-wing" also showed some promise in the testing. Here the wing tip panels of the Manta are folded under during boost to reduce drag. Again, as with any "flop-wing", the structural strength during boost is increased. The final design is the "moveable-wing flop-wing," in which the wing is "flopped" in the normal manner and also slides forward and backward on the fuselage. During boost the wing is held far back to increase the stability margin. At ejection, the wings move forward and are unfolded. He expects to be flying models of these designs in upcoming rocket/glider contests, so competition-minded rocketeers will have the opportunity to evaluate their effectiveness.

Saturday evening there were more discussion groups on different topics than those on Friday. Bob Parks led a discussion of "Radio Control in Model Rocketry." This group opened with a basic description of how pulse proportional RC units work. Then Bob indicated the usefulness of radio-control in "thermal flying"—finding a thermal with the glider and then staying in it. Since even the lightest RC units produced commercially weigh an ounce or more, practical competition RC is limited to the larger contest events—Hawk, Eagle, and Condor. For these events, several gliders are under development.

In the group on "Advanced Finishing Techniques" Andy Elliott and Guppy described some of the methods used to get high gloss competition finishes. The basic procedure is to finish the entire body and nose (without the fins and other items which cause deviations from cylindrical symmetry) is spun on a finishing machine (see *MRM* December 70). Two coats of highly thinned clear dope, followed by fillercoat, then two coats of colored dope, with fine sanding between each step, will give a nice base

finish. A buffed wax then adds the gloss. To eliminate spirals on body tubes, a layer of airplane covering tissue, shrunk and doped according to standard procedure works quite well. This technique was popular with scale builders a few years ago.

The emphasis at this year's Convention was more technical and professional than in previous years. The groups on competition modeling assumed a high level of basic knowledge on the part of the participants. The technical sessions assumed a basic mathema-

tical and computer knowledge well above the average in the hobby. Since there were few complaints that the level was too high, by aiming this way the Convention hopes to attract an even higher level of modellers next year.

## Estes Expands Marketing

Damon Corporation announced today the establishment of a network of twelve distributors to market the model rocketry hobby products of its subsidiary, Estes Industries. Since its founding in 1958, Estes has sold its products by direct mail or through hobby shops. In February, the Colorado-based company announced its entry into the mass merchandising market. According to Edward B. Lurier, Vice President of Damon's Educational Group, the distributor network will give Estes far greater penetration into the hobby shop and mass merchandising markets. The network includes Milton Bradley Co., Atlanta; United Model Distributors, Chicago and Livonia, Michigan; B. Paul Model Distributors, Inc., Philadelphia; Niagra Hobby Distributors, Inc., Buffalo; Mayflower Hobby Distributors, Inc., Hartford; Gateway Hobby Distributors, Pittsburgh; Aladdin Distributors, Inc., Minneapolis; Robertson & Robertson, St. Petersburg, Fla.; Western Toy & Hobby, Salt Lake City; Southland Distributors, Dallas; Western Model Distributors, Los Angeles;

and Academy Products, Ltd., Weston, Ontario Canada.

Since its entry into the mass merchandising market, Estes' distribution has been broadened to include Sears-Roebuck, Montgomery Wards, J. C. Penney, Marshall Field, Neisner Brothers Stores, Federal Department Stores, F. W. Woolworth, Woolco, Schultz Bros. Stores, Town and Country Stores, Grand Central, G. C. Murphy's, King's, Turnstyle Family Centers, Skagg's Drug Stores, Osco Drugs, J. L. Hudson Company, Hills Department Stores, Kress Stores, Bradlee's, Globe Discount, Gimbels, Macy's Department Stores, and Neiman-Marcus. Estes is the world's largest manufacturer of model rocketry products, and now offers over 60 model rocket kits. Its parent company, Damon Corporation, produces educational teaching equipment and a line of Damon's Lab Adventures chemistry supplies. It also manufactures medical instrumentation, electronic frequency devices and systems, pharmaceuticals and biologicals, and engineering plastics.

## Malewicki Joins L. M. Cox Co.

Douglas J. Malewicki has joined L.M. Cox Mfg. Co. as Manager of Rocket Science & Education. He will direct Cox's model rocket program and will be responsible for research and development of the entire ready-to-fly model rocket line. Malewicki brings to Cox an impressive nine-year record of involvement in aerospace and aerodynamic design, research and flight testing. He has worked on projects such as Apollo and Polaris for several key aerospace companies, including North American, Lockheed, Douglas, Philco-Ford and Cessna. Most recently he served as Chief of Engineering for a major manufacturer of model rocket kits, solid propellant engines and related launching accessories.

Malewicki is recognized as one of the leading model rocketry experts. He holds the world's model rocket absolute altitude record of 14,500 feet and flew the first successful radio-controlled rocket in national competition. Presently he is technical editor of *Model Rocketry Magazine*. An Aeronautical graduate with high honors from the University of Illinois, Malewicki also earned an M.S. in Aeronautical and Astronautical Engineering from Stanford University. He is a member of the National Association of Rocketry, American Rocket Society, American Institute of Aeronautics and Astronautics and holds a private pilot's license.

L.M. Cox, Santa Ana, Calif., subsidiary of Leisure Dynamics, Inc., is the leading manufacturer of ready-to-fly model rockets, markets the best-selling line of gas-powered ready-to-run model cars and airplanes, and is the world's largest producer of miniature gasoline engines for models.

# NEWS NOTES

## ESTES SPONSORS CONFERENCE

Seven representatives of the National Association of Rocketry recently participated in a two day conference sponsored by Estes Industries and held at the company's headquarters in Penrose, Colorado. Attending the symposium - - the first of its kind in model rocket history - - were Robert Atwood,

Annapolis, Maryland, NAR trustee, Director of NAR Section Activities, and former senior advisor for the Annapolis Association of Rocketry; Ben Russell, Houston, Texas representing the NAR Southwest Division manager; Richard Toner, Southland Div. Manager and advisor to the Hornet's Nest Model Rocket Club; Manning Butterworth, Chicago Illinois, Mid-American Division manager; Lee MacMahon, Bellflower, California, Pacific Division manager; Mel Severe, Arden, Colorado, Mountain Division manager; and Tag Powell, Highland Park, New Jersey, Northeast Division manager.

Hosts for the symposium were Vernon Estes, president of Estes Industries; Robert L. Cannon, executive director of Communications. Topics covered during the round table sessions included such NAR activities as newsletters, social workshops, and membership drives. A new approach to the promotion of model rocketry on a national and international basis, the conference gave the participants from NAR a unique opportunity to exchange ideas that will be of considerable value to them during the performance of their official duties.



Manning Butterworth and Robert Atwood look on as Vernon Estes explains details on their Saturn at the NAR Regional Managers' Conference.



Douglas J. Malewicki, newly announced Manager of Rocket Science and Education for L.M. Cox.

# MPC Introduces Minijet Engines

New miniature engines, capable of revolutionizing the low power competition events have been introduced by Model Products Corporation. These 1/2" diameter engines are available in 1/8A, A, and B sizes. A completely new line of six high-flying miniature rockets accompanies the new engines. Called the "Miniroc" line, the rockets are about one-half inch in diameter and are half the weight and considerably more streamlined than standard model rockets, according to G. Harry Stine, designer of the line.

All have balsa noses and fins, and fiber body tubes. Because of the sizes difference between "Miniroc" and standard model rockets, a new series of engines was developed to fit the rockets. The engines are 13mm in diameter and 57mm long. The heaviest of them weighs 10 grams, about half the weight of a comparable standard size engine. Burnout weight is 3.5 grams on all engines. They contain the same propellant and provide power equal to that of the standard size engines of the same power designation.

"Because MPC's "Minirocs" are smaller, faster flying and lighter, they fly higher than standard size model rockets and were designed for setting records on the flying field and for recapturing many of the international records now held by Europeans," according to Stine.

The MPC "Miniroc" line includes the "Pipsqueak," a high-performance altitude model only six inches long. With a Type B3-5m "Miniroc" engine in its tail, "pipsqueak" weighs 16 grams at liftoff, giving it a maximum altitude capability of more than 2,000 feet. Two "Pipsqueak" models will come in each kit, since one is sure to be lost almost immediately.

"Super Star" is also an altitude model designed more conservatively to allow for ease of tracking by NAR-type equipment. It is 11 inches long and weighs 20 grams



The new Minijet (right) is only 13 mm in diameter compared to the 18 mm diameter of a standard engine. Note that the inner diameter of the Minijet is almost the same as the standard B-engine at right.

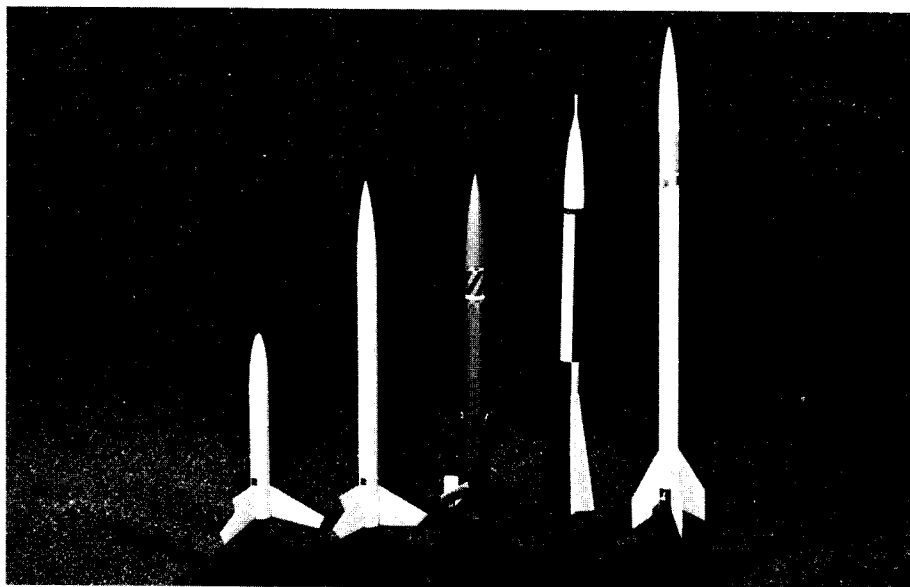

The new "Minirocs," miniature rockets designed for use with the new engines, are (left to right) the Pipsqueak, Super Star, Tarus-1, Asp-1, and Astrobee-D. A canard boost/glider, the Delta-Katt, will also be introduced.

with a B3-5m engine installed. It, also, is capable of attaining altitudes in excess of 2,000 feet with a B engine.

Both the "Pipsqueak" and "Super Star" show the significant increase in performance of the "Miniroc" line. Their maximum altitude is more than twice as high as an ordinary altitude model propelled by an MPC B6-4 engine. The 13mm engine allows models to be built with almost 50% reduction in frontal area over the 18mm engine model.

The "Miniroc" "ASP-1" is a 1/11 scale model with a total length of 13 inches and a launch weight of 27 grams.

The "Astrobee-D" is a 15.6 inch scale model of the sounding rocket made by Aerojet General Corporation. It is finely

detailed, incorporates a payload compartment and has a launch weight of only 5 grams, with a B3-5m engine installed.

A unique boost/glider, the "Delta-Katt," looks like something out of the future and holds the promise of recapturing the international records in boost/gliders for the U.S.A., according to MPC. It features 17.6 square inches of wing area.

Completing the MPC "Miniroc" line is the "Tarus 1" sport model, designed to resemble the sounding rockets flown by NASA From Wallops Island, Virginia.

MPC's "Miniroc" engines, which may be used in the standard model rockets fitted with a special adaptor, come in Types 1/8A3-3m, A3-4m, and B3-5m. Other delays to be introduced later.

## MPC MINIJETS MAKE 1ST PUBLIC APPEARANCE AT MIT CONVENTION

by George Flynn

The first public demonstration of the new MPC Minijet engines took place at the MIT Convention. In an impromptu launch, on Saturday April 3rd, G. Harry Stine held a launch on a field near the Convention center. About 50 rocketeers gathered around as the half-inch diameter engines put on quite a show.

The first rocket off the pad was a small—*Very, very small*—model. We didn't get an estimate on the altitude, since the model broke the cloud layer. The same thing hap-

pened to the B-powered PeeWee, one of the new models in the MPC Miniroc line. "That's why you get two PeeWees in each kit," Stine remarked as it went through the clouds.

Then came the Delta-Katt, the boost/glider in the Miniroc line. Sitting on the pad that canard B/G really looked strange, but the boost was good and then it went into glide! Thirty-five seconds on a new Minijet A-engine isn't bad, especially since the new glider was still under development at the time.

By the close of the demo launch, the new MPC engines were the talk of the Convention.

# A HIGH-PERFORMANCE COMPETITION DESIGN FOR THE NEW 1/2 A "PD" EVENT.....

## The "Enayar"

by Steve Fentress

Many rocketeers feel that it is wasteful to design a competition model with good looks in mind. The Enayar proves that I don't agree! a competition model is much more fun if it has some personality, and what's wrong with that? When model rocketry ceases to be fun, it's time to get out and try something else. Anyway, the rocket described in this article certainly has a personality all its own.

The Enayar combines the best in good looks and good performance. It was designed for low-power parachute duration competition—especially the new PD category for 1/2 A engines. It is also one of the best looking rockets I have ever seen, if I do say so myself. The Enayar is very good for "on-the-shelf" displays at exhibits and fairs, and plastic-haters should love it. It is fairly difficult to build since it uses some new finishing techniques, more familiar to the makers of fine furniture than to modroc hobbyists.



Artist's conception of the Enayar descending on its parachute after a high-altitude PD flight.

The first step in building your Enayar is, of course, to get required materials together. Along this line, as soon as you get the 1/32" plywood home from your friendly hobby shop, put it between the pages of a heavy book and store it horizontally. This is to prevent warping which occurs easily with thin plywood.

Start construction with the body tube. Cut the BT-20 to length and install shock cord and an engine block. If you plan to launch your Enayar from a rod, glue on a launch lug as shown in the drawing. Tower launching obviously will require no lug.

Finishing starts right away, with bright orange glossy spray enamel. You will notice from the drawing that only the tail end of the body tube is not covered by silver mylar or Monokote, so you will not need to spray-paint more than about the last four inches of the tube. Apply light base coats of paint as usual. Two fairly light coats should do the job. Now the last coat is not sprayed on "wet" as is normally done to produce a high-gloss finish. Put on only light "mist" coat, just enough to give solid color and a sandy-looking surface. As the paint dries, it should not "flow" into a smooth finish, it should harden into a slightly rough surface, something like an orange peel. This sounds like bad workmanship, but it adds a great deal to the overall appearance.

While the orange paint is drying, you can cut out the plywood fins. The shape is an adaptation of a low drag design published by G. Harry Stine a couple of years ago. Cut out the fins so that the outside grain of the plywood — the grain you see — is parallel to the leading edge of each fin. Use a sharp X-Acto knife for the cutting. Make each cut with several light strokes. Don't worry at this stage about rounding the corners, they will be rounded during the sanding.

Start the sanding operation on the fins with the root edge. This edge must be flat and *perfectly square*. If it is not, getting a good bond between the fin and body tube will be just about impossible. The area of contact between two glued surfaces must be as great as possible for a strong joint. Now start sanding the sides of the fin, using 320 grit paper. Any roughness or fuzz should be removed first, then the airfoil shape is sanded with 320 paper on a sanding block. Be very careful as you sand away the outer layers of the plywood, since the inside layer of wood will tear very easily. After shaping the fins, smooth the surface with 400 grit sandpaper, followed by 600 grit. The fine grain in the plywood will give a very smooth surface that needs no filling. On this design, it is essential that no fillers or sealers be applied yet.

When the fins are done, set them aside and sand the nose cone with increasingly fine sandpaper until it is as fine as you can get it. *Apply no fillers or sealers to the nose cone at this time.*

Now the fun starts. You will now apply a finish to the wooden parts of your Enayar in the same manner in which you might finish a piece of furniture. Start with the stain. Staining is the process of applying a dye to a piece of wood in order to enhance its color, its grain patterns, and its general "woody" look. Since neither balsa nor modeler's plywood has much in the way of color variation or grain "figures," these must be applied artificially. It will be very difficult to make up a grain pattern from imagination, so look around and locate some piece of furniture or some other wooden



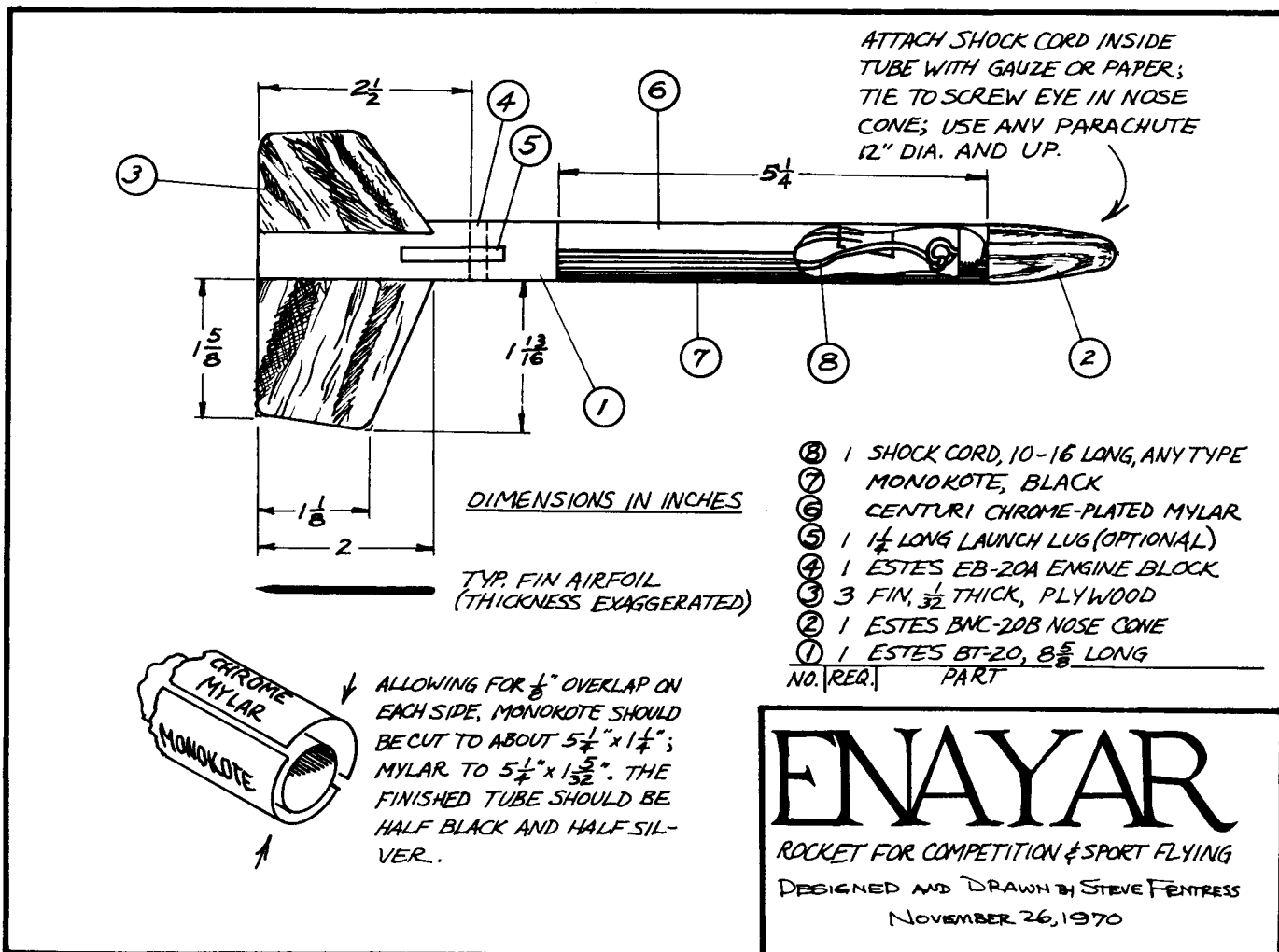

object with interesting markings in it. You will copy this pattern onto the rocket parts.

Now for the stain — use the same stuff that is used on furniture. You can buy it at any hardware store if you don't have any at home. Furniture stain is available in several different colors — pick out one that looks good to you. The original Enayar was done with Sherwin Williams Oil Stain in the "American Cherry" shade. Practice on a piece of scrap plywood first. With a medium-sized brush, apply a coat of the stain, which should be well-stirred beforehand. Let it lie on the surface for about a minute, then wipe it off with a rag. The stain which has soaked into the wood will give it an even background color. (Now you see why there must be no fillers or sealers on the wood.) With a smaller brush, try to imitate the grain pattern in your sample piece. One method of getting a realistic pattern is to paint wavy lines in the wood with the stain, let it soak in a few seconds, then smear it in one direction with a rag. Try anything that seems to work until you get the feel of the process. To lighten the color, rub mineral spirits or turpentine into the wood, using a rag for large areas and a Q-tip for small details. You can work the color back and forth like this for some time. The only restriction is that you must not spend too much time on one side of a piece of plywood, or it will warp. After you have stained the fins, use the same methods on the nose cone. However you must work much faster since the stain takes much less time to soak in and darken balsa than plywood. The big secret of this whole "phony grain" process is to quit while you are ahead. If you work too much on one area it will become a muddy-looking mess! Oh, yes . . . remember that the features and therefore the brushstrokes run generally in the direction of the grain.

The wooden parts should just barely feel damp when the staining is completed. Set all the parts on a smooth, clean surface (its alright for the fins to lie on one side) and let the stain dry a full 24 hours. It takes that long for the solvents to evaporate out of the wood.

While the stain is drying, cut out the black Monokote and the silver mylar. Put the Monokote on the tube first, following the

directions that come with the material. Be sure that all the edges, especially the forward edges, are down tight. Next, peel the backing off the Mylar and carefully stick it to the tube. Be sure that the bottom edges of the Monokote and the mylar line up perfectly and that the longitudinal edges are in line with the tube. (The original idea behind this covering was that the Monokote would absorb heat from the sun and the mylar would reflect it, this providing a way of controlling the temperature of the parachute packed inside the rocket, according to the alignment of the rocket on the pad with respect to the sun. More than once my PD flights have flopped because the parachute was either too warm and sticky or too cold and stiff. Whether this system really makes any difference is still uncertain, but it is great for visibility.)

Now all the parts for the Enayar are about finished, and almost all that is left is to get it all together, so to speak. Attach the fins by carefully scraping the paint off the area where they will touch the tube, then use a double-glue joint to hold the fins on. Use a celluloid cement such as Ambroid for this, because Titebond and the white glues are too flexible, especially in warm weather, for the fin materials as thin as we are using on this model.

The last step is the application of varnish on the wooden parts. Use regular furniture varnish, thinned with about one part of turpentine or mineral spirits to six or seven parts of varnish. (Clear dope or clear enamel will not look as good as varnish.) Brush on very thin coats. You should have no trouble keeping the varnish off the body tube at the fin roots if you are careful. Let each coat dry at least four hours, and use five or six coats, rubbing with extra-fine steel wool after all coats except the last one. You can create spin fins if you want them by putting an extra coat of varnish on only one side of each fin. The resulting warp should make the rocket spin nicely and will create a novel flashing appearance in flight as the alternate black and silver surface comes into view.

Your Enayar is now finished. It is very stable and will fly with any engine that will fit in a BT-20, from a ¼A to (I suppose) the new Enerjet D's. For flying with short (Series III) engines, insert two ½" stage couplers behind the engine block.

# CLUB CORNER

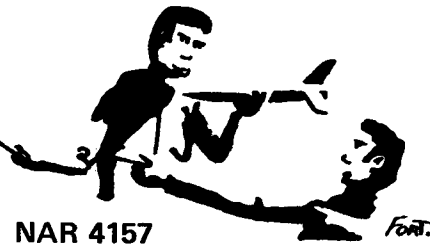
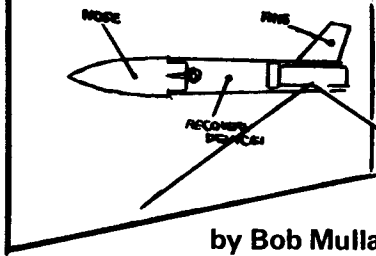

## by Bob Mullane NAR 4157 FLIGHT DEMONSTRATIONS

The best way to acquaint the public with the excitement, fun, and safety of model rocketry is to present a demonstration launch. No matter how much or how well you write or talk about rocketry, nothing matches the impact of a live demonstration. However, a demo must be well *planned, prepared, and executed* to be effective. That's what we'll cover this month—how to give a good demonstration.

Naturally, the first step is to select a place and time for the demo. Many opportunities should be present. A few places include school science fairs, county fairs, model airplane meets, encampments of groups like the Boy Scouts, YMCA, CAP, and Boy's Clubs, Airforce shows, ect. Whenever you read or hear a notice about one of these events, contact the organizers to see if they would be interested in a rocketry demonstration. Often you'll find the schedule is already too full for a demo, but ask them to keep you in mind when they're planning the next one. You'd be surprised how often these contacts pay off. Once the arrangements have been made for the demo, send out publicity about it. (See last month's "Club Corner.")

Start planning as soon as the date is set. Make sure you have all the necessary equipment (launcher, PA system, crowd control equipment, ect.). If you'll be giving many demos, you may want to build a special brightly painted, portable rack just for use at demonstrations. Check to see that all the equipment is in good working order and the clips and rods are clean. This check should be repeated the night before the demo. If you have to stop to repair a launcher or PA on the field, you'll find that you've lost your audience.

You don't have to launch a lot of rockets (about 8 to 12 should do), but they should all be well built and attractive. **NEVER use an untested rocket at a public demonstration.** Use rockets of various types starting out with a simple model (one stage, streamer recovery) and building up. A good mixture would be: a streamer recovery rocket, parachute, a boost glider, a two-stage model, a high-performance model, a scale model, and a cluster or big engine bird. A sure fire crowd pleaser is an egg loft, but pick a reliable one. To let the spectators see the full flight of the rockets, fly most with small engines to keep them down to an altitude of only a few hundred feet. (Be careful not to underpower them! Test each rocket in advance, with the same type engine you'll be using at the demo.)

You should have a demonstration team

of about 6 to 10 members to give the demo. If there are any girls in your club, some of them should be on the team. The team should have members of many ages. These two things help to show that rocketry isn't "just for boys" and that it is for "all ages." The demo team should go to inspect the launch site ahead of time (if you are unfamiliar with it).

The members of the team should choose their jobs (firing officer, public relations officer, rocket prepers, recovery crew and crowd control) and a "dry run" or rehearsal should be held to see if everyone understands his (her) job. The team should present a neat appearance and should go about the job of the demo seriously. "Horsing around" during a demonstration can't be tolerated.

Now, the demo is set up, the team and birds chosen and ready, all equipment checked (needed repairs made), transportation to and from the demo arranged, and the big day is here. Make sure everyone knows how to get to the site and that you've packed everything you'll need. A checklist of all necessary equipment and literature should be prepared and checked off as each item is loaded into the cars. Don't neglect any item no matter how small it may seem. (Arriving at the demo without ignitors could ruin your whole day.)

Plan to arrive early and take your time setting up your equipment. Test everything one more time as soon as it is set up. Mark off a spectator area and have members to

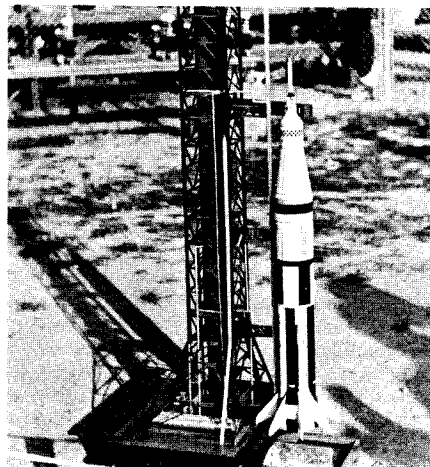

**A scale rocket everyone will recognise attracts interest in your demo launch. The Centuri, Estes, or Cox Saturns or the MPC Vostok are really crowd pleasers — especially if you build a semi-scale launch pad.**

keep the spectators in that area and pass out information about your club. A printed handout (sometimes called a "throw away" because of what most people do with it) should have been prepared to briefly explain model rocketry and your club. It should also contain the name and address where they can contact your club. You might also want to obtain information from the manufacturers to be given away. While you're setting up, you may wish to allow the spectators to take a closer look at the launch pad and the birds being prepared.

When the time to begin launch is near, clear the spectators back and begin to launch. The public relations officer should keep up a constant explanation of the rockets. Explain each rocket before its flight, and describe each step of the flight as it takes place (thrusting, coasting, ejection, ect.). Explain the workings of rockets in general, tell about your club, don't let interest ever wander. As already mentioned, fly the rockets in order from the simplest to the most complex. The total flight demo should last about 15 to 20 minutes. Thank the spectators and remind them that they can contact you for more information. If you'll be repeating the demonstration during the day, announce when launching will begin again. When you are finished, take your time cleaning up. A few people will remain to ask more questions. These people are your best candidates for potential members. Spend some time answering their questions, it will be well worth your time.

Before you leave, thank everyone involved and check to be sure that you haven't left anything (or anyone) behind. As with any launch, you should leave the field in the same condition you found it. People who leave the field littered with trash and their handouts usually don't get invited back to give another demonstration.

When you get home, evaluate the demonstration. Figure out what you might be able to do better next time, what flights impressed the crowd. Try to decide if you had enough (or too many) flights. In general, use the experience of each demonstration to make the next one better.

On July 25 NASA will provide you with a great opportunity for a demonstration — Apollo 15. This is a Sunday launch and, since it is summertime, most of the country should have good flying weather. Start planning a demo now. Select a site and time, get publicity out, and start building rockets. Of course, you'll want to launch a Saturn V, but why not launch a model of every type of manned rocket flown? Your club could appoint a different member to build each rocket. They should all be built to the same scale. If you limit the launch to United States rockets, start out with a Mercury-Redstone, then Mercury-Atlas, Gemini-Titan, Saturn 1B, and finally Saturn V. To complete the set, add an X-15. To extend the demo internationally, you should add a Vostok, Voshod, and a Soyuz. Since the data on all three of these Russian rockets might be difficult to obtain, you might want to just fly a Vostok. (Remember, if you fly them in historical order, fly the Vostok first.) If you're really ambitious, build the proper scale launch pad for each rocket. **THAT would be really impressive!** Good luck, let us know how your demonstration turns out.

RADIO CONTROL  
ODD BALL

MODEL ROCKET ELECTRONICS  
TECHNICAL ARTICLES

COMPETITION  
BOOST GLIDERS

# Back Issues!!!

TRACKING SYSTEMS  
CAMERA ROCKETS

PAYLOAD ROCKETS  
FINLESS ROCKETS

CLUB NEWS  
SCALE MODEL ROCKETS  
LAUNCH SYSTEMS

SUPPLY LIMITED ORDER TODAY!

**November 1968** \$ .75 □  
 Model Rocket Recovery by Extensible Flexwing . . . .  
 High Quality Aerial Photography: Part 1 . . . .  
 Calculating Drag Coefficients . . . . Scale: MT-135 . . . .  
 Project Apollo . . . . XR-5C: Three-Stage Cluster . . . .  
 The Versitex: A Payload Rocket . . . .

**February 1969** \$ .75 □  
 Zeta: Single-Stage Sport Rocket . . . . The Flight of  
 Apollo 8 . . . . Non-Vertical Trajectory Analysis . . . .  
 The Old Rocketeer: Spotlight on the Manufacturers . . . .  
 Cosmic Avenger: A Model for Class E Engines . . . .  
 Scale Design: Nike-Deacon . . . . Model Rocketry for  
 the Depraved . . . .

**March 1969** \$ .75 □  
 The Old Rocketeer: Saffek's Saturn . . . . High Quality  
 Aerial Photography: Part III . . . . The Blurificon:  
 Rocket Design . . . . Constructing a \$25 Club Launch  
 Panel . . . . How to Finish a Model Rocket . . . . Scale  
 Design: Genie MB-1 . . . . The Dynafiora: Single-Stage  
 Sport and Payload Rocket . . . .

**April 1969** \$ .75 □  
 Scale: Arcas . . . . Report on Apollo 9 . . . .  
 Demonstration Launches . . . . R. H. Goddard:  
 Payload Rocket . . . . Multistage Altitude Calculations  
 . . . . Tower Launching . . . . Torsion Wire Experiments  
 . . . . The Skyray . . . . Chicago Trade Show . . . .

**May 1969** \$ .75 □  
 Staged vs. Cluster Model Rocket Performance . . . .  
 The Fra-jyle: Sport Rocket . . . . Astroscale Data: The  
 ASP Rocketsonde . . . . Transmitter Construction  
 Plans . . . . The Infinite Loop: Oddball Design . . . .  
 The WRESAT: Australian Satellite . . . . Pittsburgh  
 Convention . . . . The Hawk: Sport Rocket . . . .  
 Closed Breech Launching . . . .

~~**June 1969** \$ .75 □  
 Ignition Technology . . . . Build a Temperature Sensor  
 for Transmitter Use . . . . Body Tube Guide . . . . The  
 MIT Convention . . . . The Candelabra: Oddball Design  
 . . . . The Thumba Rocket Range . . . . Scale Design:  
 Lost Tomahawk . . . .~~

**July 1969** \$ .75 □  
 Soviet Space Program . . . . Scale: Astrobee 1500 . . . .  
 ECRM Results . . . . F Engine Saturn . . . . Mistfire  
 Alley System . . . . The Goliath . . . . The Why(1)gion . . . .  
 . . . . Spin Rate Sensor and Direction Sensor for Rocket  
 Transmitter . . . .

**August 1969** \$ .75 □  
 Radio-Controlled Boost/Gliders . . . . A History of  
 Retro-rockets . . . . An Accelerometer for Transmitter  
 Use . . . . Results from WAMARVA-1 . . . . The  
 Dynamite . . . . Scale: Rohini RH-75 . . . . The Old  
 Rocketeer: Flat Cat B/G . . . .

**September 1969** \$ .75 □  
 Color Aerial Photography . . . . The Flight of Apollo  
 11 . . . . Astroscale Plans: Black Brant III . . . . South  
 west Model Rocketry Conference . . . . Payload  
 Section for the Transmitter . . . . Czechoslovakian  
 National Championships . . . . Plastic Scale Modeling  
 . . . . Radio Controlled Boost/Gliders: Part II . . . .

**October 1969** \$ .75 □  
 Conical Model Rockets . . . . Astroscale: Nike-Smoke . . . .  
 . . . . Fin Test Vehicle . . . . Foxmitter Microphone . . . .  
 NARAM-11 Coverage . . . . R/C B/G: Part III . . . .  
 Japanese Activity . . . . Dragbrakes Revisited . . . .

**November 1969** \$ .75 □  
 Scale: Nike-Apache . . . . Midwest Regional Report . . . .  
 . . . . Arcturus: Finless Design . . . . Ball-Hagedorn Open  
 Payloader . . . . Jupiter-C Conversion . . . . Washington  
 State Championship . . . . Krushnik Effect . . . .

~~**December 1969** \$ .75 □  
 Yugoslav Championships . . . . Relay Launch Systems  
 . . . . Coefficients . . . . The Humble Bee: Hornet B/G . . . .  
 . . . . Aerial Photo Interpretation . . . . Designing with  
 Computers . . . . B/G Performance: Part I . . . .  
 ECRM Regional Report . . . .~~

**January 1970** \$ .75 □  
 Return to Green Mountain . . . . Tilt-A-Tower . . . .  
 B/G Performance . . . . MARS-IV Regional Results . . . .  
 . . . . Retro-Rocket Designs . . . . Calculating Drag  
 Coefficients . . . . USSR Championships . . . . Modrocs  
 in Vietnam . . . . Fly the Micron II . . . . Pershing I  
 Scale Data . . . .

**February 1970** \$ .75 □  
 Ram-Air Guidance . . . . Yugoslavian Parachute  
 Duration Design . . . . Computer Altitude Calculations . . . .  
 Build the Warwick II . . . . B/G Performance: Part II  
 . . . . Body Tube Construction Techniques . . . .  
 Helicopter Recovery Techniques . . . . Super-Swift  
 Tandem B/G's . . . .

**March 1970** \$ .75 □  
 Converting the Revell LEM to Flight . . . . B/G  
 Performance: Part III . . . . Plastic Fin Modifications . . . .  
 . . . . Parallel Fins for Modrocs . . . . Ram-Air Guidance:  
 Part II . . . . Fly the Super-Titan . . . . D-Engine Flight  
 Performance Charts . . . .

**April 1970** \$ .75 □  
 Modroc UFO's . . . . HAD Scale Australian Rocket . . . .  
 Trade Show Report . . . . Rear Ejection Clip . . . .  
 Psionic Control of Modrocs . . . . C<sub>D</sub> Determination . . . .  
 . . . . D-Engine Performance: Part II . . . . Fly the  
 NARWHAL For Design Efficiency . . . .

**May 1970** \$ .75 □  
 Thunder Bird Eagle B/G Plans . . . . The First Model  
 Rockets . . . . Vostok USSR Scale Plans . . . . Paint  
 Compatibility . . . . The Omega Quadrathon Design . . . .  
 . . . . The Trojan Flint Test Vehicle . . . . Optical  
 Temometry . . . . Lift, Drag, and Pitching Moment  
 Coefficients for the Nighthawk B/G . . . .

**June 1970** \$ .75 □  
 The S S Orion Flying Saucer Rocket . . . . Plastic  
 Conversion: The Countdown Saturn V . . . . Saffek's  
 Hiskra B/G . . . . Simplified Parachute Duration  
 Analysis . . . . Oberon XBG-111 Styrofoam Wing B/G . . . .  
 . . . . Build the Sport . . . . Pittsburgh Convention  
 Report . . . . The Foxmitter II Modroc Transmitter . . . .

~~**July 1970** \$ .75 □  
 ECRM-4 Report . . . . Korolev RD-107 Vostok  
 Astroscale Plans . . . . The "Triad" Odd-ball Design . . . .  
 . . . . MIT Convention Coverage . . . . Custom Plastic Parts  
 . . . . Czech Competition Coverage . . . . Foxmitter  
 Breathing Rate Sensor . . . . Strap-On Wind Tunnel  
 Plans . . . . Experimental Parachute Duration Results . . . .  
 . . . . Plans for the Topsy . . . .~~

~~**August 1970** \$ .75 □  
 Flop Wing B/G's . . . . Titan III-M with Operational  
 Strap-Ons . . . . Boeing Wind Tunnel Plans . . . .  
 NART-1 Contest Coverage . . . . "Bio-1" Payload  
 Rocket Plans . . . . Foxmitter II Temperature Sensor . . . .  
 . . . . Pivot Launch Tower Plans . . . . RD-107 Vostok  
 Scale Data: Part II . . . . EFA Pauloader Sport Design . . . .~~

~~**September 1970** \$ .75 □  
 Plastic Conversion: Revell "Vostok" . . . . Quick and  
 Easy Balsa Finishing . . . . The Dove III Flop Wing  
 Sparrow B/G . . . . Falcon (MIM-4E) Scale Plans . . . .  
 PAR-1 Regional Meet Coverage . . . . Accelerometer  
 Plans for the Foxmitter II . . . . "Bio-1" Payload  
 Rocket: Part II . . . . The Flying Bowling Pin . . . .~~

Allow at least 6 weeks for delivery.

Model Rocketry Magazine  
 Box 214  
 Boston, Mass. 02123

Name.....  
 Address.....  
 City.....State.....Zip.....

# THE MODEL ROCKETEER



NATIONAL ASSOCIATION OF ROCKETRY, Box 178, McLean, Virginia 22101

## What is the LAC?

by Elaine Sadowski

*The Model Rocketeer* is published monthly in *Model Rocketry* magazine by the National Association of Rocketry, Box 178, McLean, Virginia 22101. The National Association of Rocketry, a non-profit educational and charitable organization, is the nationally recognized association for model rocketry in the United States. *Model Rocketry* magazine is sent to all NAR members as part of their membership privileges. NAR officers and trustees may be written in care of NAR Headquarters. All material intended for publication in *The Model Rocketeer* may be sent directly to the editor.

### Officers of the Association

James Barrowman	President
Bryant Thompson	Vice President
Jay Apt	Secretary
John Worth	Treasurer
Robert Atwood	Section Activities
Lindsay Audin	Publications Comm.
Carl Kratzer	Public Relations
G. Harry Stine	Liason Committee
Gerald Gregorek	Standards & Testing
Ellsworth Beetch	Trustee
Howard Galloway	Trustee
Alfred Lindgren	Trustee
Forrest McDowell	Trustee
Richard Sipes	Trustee
William Roe	Honorary Trustee
Leslie Butterworth	Honorary Trustee

<b>The Model Rocketeer</b>	<b>Technical Services</b>
Carl Kratzer, Editor	Slot & Wing Hobbies
320 Thurston Ave.	511 South Century
Ithaca, NY 14850	Rantoul, Ill. 61866

<b>NAR Contest Board</b>	<b>Leader Admin. Coun.</b>
Richard Sipes	Elaine Sadowski, Sec.
5012 60th St.	1824 Wharton St.
Hyattsville, MD	Pittsburgh, PA 15203

<b>Northeast Div. Mgr.</b>	<b>Southland Div. Mgr.</b>
Tag Powell	Richard Toner
714 Raritan Ave.	5012 Valley Stream
Hightland Pk, NJ	Charlotte, NC 28209

<b>Mid-Amer. Div. Mgr.</b>	<b>Pacific Div. Mgr.</b>
Manning Butterworth	Lee MacMahon
Rm 315, 5540 Hyde Pk	13629 Ardis St.
Chicago, Ill. 60637	Belleflower, CA

<b>Mountain, Div. Mgr.</b>	<b>Southwest Div. Mgr.</b>
Mel Severe	Forrest McDowell
8361 Chase Way	10058 Larston Street
Arvada, Col. 80002	Houston, TX 77055

As I was looking over the NAR Membership Questionnaires sent out with the last renewal packet, I noticed that an amazingly low number (to me, anyway) of NAR members are aware of the purpose, and possibly even the existence of the LAC. I've been on the LAC (LAC, by the way, stands for Leader Administrative Council) for four years, and I've served as both secretary and chairman, so, of course, I'm quite interested in it, and I'd like to briefly explain its purpose, its history, and some of its projects.

The Leader Administrative Council is an NAR Committee made up of seven elected leader members. It was formed because leader and junior members have long been desirous of doing something to benefit the NAR on a national level. The LAC's purpose is to come up with projects that will be useful to the NA and carry them out, involving, if possible, other leader and junior members.

In 1967, at NARAM-9, the LAC was approved by the Board of Trustees as a provisional committee. The first LAC was also elected at NARAM-9 from the leader members present by the leader and senior members who were in attendance. Those seven people were Jay Apt, Lindsay Audin (the first chairman), Talley Guill, Ed Pearson, Joe Persio, Ray Stanford, and myself (serving as secretary). Both Jay and Lindsay are now on the Board of Trustees, with Jay as Secretary of the NAR and Lindsay as LAC Advisor and Publications Committee Chairman. If these people could come up with some good ideas and prove that the LAC was a viable concept, then the committee would be approved on a permanent basis.

In 1970, at NARAM-12, the LAC was approved as a permanent committee. Election procedures have been revised to enable people not attending NARAM's to run for the LAC and to vote for LAC members. Those people wishing to run have submitted resumes. Eligible voters (all NAR senior and leader members) should read these resumes and vote for seven people.

Perhaps the best-known LAC project is the Newsletter Award. All NAR sections having newsletters are eligible to compete for this award, which is given to the section newsletter that best promotes section spirit and most effectively acts as a means of communication among section members. The trophy was first awarded in 1969 to *Zog 43* of NARHAMS. In 1970 it went to *Con-Trail* of the Three Rivers Section.

Among the LAC projects of past years are an analysis of NAR membership by geographical region, a field trip involving a number of sections in the New York-New Jersey area to Grumman Aircraft, and a survey of leader members in an effort to determine their career plans. This last project was an attempt to encourage aerospace firms to contribute to the NAR because it is an educational organization and may help to produce more scientists and engineers. The project was, obviously, carried out before somebody decided to wipe out poverty, end war, and generally overcome evil by putting lots of aerospace engineers out work. The *NAR Technical Review*, a publication which, unfortunately, lasted for only one issue, and which was an attempt at compiling a collection of good technical articles, was also a LAC-conceived project. The *NAR Section Manual*,

a sort of how-to-do-it guide for sections, was started in 1967. It now has grown to a six-chapter publication covering such subjects as how to hold a demonstration, newsletter hints, suggestions for holding contests, and many others. A seventh chapter, this one on photographing model rockets, is being written this year. A new edition of the *Manual* is currently in preparation.

LAC members have also drawn up suggested criteria to be used in the selection of contestants for international meets, and they have attempted to collect R&D reports for publication.

The questionnaire in the renewal packet was also a LAC project. This was an outgrowth of the NAR evaluation seminars which have been held by LAC members at conventions and NARAMS. The results will be analyzed, and, hopefully, we can discover how the NAR membership feels about the NAR and what they would like to see done.

The Newsletter Award is being carefully examined this year. The results of this examination appear in this month's *Model Rocketeer*. Among the other projects going on this year are the collection of scale data to be made into scale packets for NAR Technical Services and an examination of the feasibility of preparing sets of slides for use by sections and by people who want to start sections.

The LAC encourages participation from all leader and junior members. Anybody who has an idea for a project, anybody who would like to help out on a project, or anybody who'd like to make a comment or suggestion should write to the LAC Secretary. LAC meetings have been held during the Thanksgiving weekend, at the Pittsburgh and/or MIT Conventions, and at NARAMS, although meeting times and places may change with the election of a new LAC. LAC meetings are open to all NAR members, and anyone interested in attending any of them should contact the LAC secretary.

The results of past LAC projects have shown that junior and leader members can indeed work to help the NAR, but the work of the LAC would be even more effective if others would join in it more often.

---

## The LAC As a Forum

by Robert Mullane

In addition to carrying out projects, LAC also acts (to some extent) as a forum for ideas and a means for communication. We'd like to present a few of the ideas LAC has discussed in the past year, and, through this, encourage further thinking and maybe even some "New Think" among NAR members.

One idea presented concerned preventing a committee which is responsible for choosing or nominating a NAR member for any purpose (such as selection to the Internats team) from selecting any of its committee members for this task. After discussion, the idea was rejected. It was thought that the NAR is too small at this time to have enough qualified members not serving on the committee to allow such a restriction.

Another motion concerned criteria for selection of people to do a job, and stated that attendance at NARAM should not necessarily be one of the criteria. It was decided that NARAM attendance has probably not been a criterion in any selections made to date, but that people who have been to NARAMs are more likely to be known to be able to qualify for such an appointment.

## THE MODEL ROCKETEER

In an attempt to discover ways to raise money for the NAR and support *MRm*, a suggestion was made that all manufacturers be required to take a full page ad in *MRm*. In return they would receive a NAR endorsement. This proposal was rejected on the basis that it was out of LAC's jurisdiction (and impractical besides). Other ideas for fund-raising included charging an extra fee for attendance at NARAMs and conventions, and to encourage all NAR members who write model rocketry articles for publication to donate a share (amount to be determined by the individual) of his payment to the NAR. The first was rejected; the author's donation idea was accepted and passed on to the Trustees for consideration. Any ideas to aid the NAR financially are welcome from the membership.

Another idea was to document and publish the results of all protests which are made in competition. Since most protests concern minor points, the proposal was rejected.

A proposal to set up a series of regional elimination meets to be held each year and choose "Region Champions" to compete at NARAM is now being investigated by LAC member Arnie Pittler.

A proposal by Richard Malecki to create a raffle which would be entered by all sections (with a donation from each) is being investigated by Rich. The names of all the sections would be placed in a barrel and one name selected. The winning section would be given the money in the fund to present to one (or more depending on the amount) of its members to allow him (her) to attend NARAM that year.

These are a few of the ideas which LAC has received and discussed. We hope that the membership will take an interest in the operations of the NAR, propose ideas to the LAC and Board of Trustees, think about what's been said here and in other articles, and let us know what you think. We don't know what you are thinking unless you write us and tell us.



I hope that the abundance of LAC material in this issue doesn't bore anybody. The new LAC is about to be elected and the renewal questionnaires show that out of 1,410 people returning them, only 410 people were familiar with the LAC. That's a little more than 29%, a pretty poor showing. If the election is to be effective at all, NAR members ought to know what LAC members do. In the past, some people have gotten elected on popularity alone, with disastrous results. So, if you want the LAC to be an effective body, and if you want the LAC to serve you, please, read about the LAC, and by all means (if you're a Leader or Senior) vote--right now, while you've got the magazine in your hand.

This is my first issue, and I'd like to thank all the people who helped me out, those who sent articles, and especially the LAC (Bob Mullane in particular), NAR president Jim Barrowman, Ed Pearson, and Carl Kratzer (for providing advice and moral support). Any comments, suggestions, articles, plans, ideas, etc. will be gratefully accepted.

Elaine Sadowski

# LAC Election

At the bottom of this page you'll find the ballot for the election of the members of the NAR Leader Administrative Council for 1971-1972. All Leader and Senior NAR members are eligible to vote. We urge you to read the following resumes, carefully choose the seven Leaders you wish to be on the LAC, and fill out and return the ballot *today*. After checking off seven names, please attach your address label from this issue of MRm and sign the ballot. *No ballot will be accepted without the address label.* This is necessary to insure that only eligible people vote. All ballots will be handled with strict secrecy. Cut out the completed ballot and return to: LAC Ballot, c/o Bob Mullane, 34 Sixth Street, Harrison, New Jersey, 07029. *All ballots must be received before Saturday, August 7, 1971.* The results of the election will be announced at NARAM 13 and in a future issue of *The Model Rocketeer*.

**Charles Andres**, NAR 7829 has been a model rocketeer for six years and an NAR member since 1966. He organized the first NAR section in Maine and was President of the Berwick Academy Rocket Society for four years. Mr. Andres attended and placed at both NARAM 11 and 12. He has written several articles for *Model Rocketry* magazine over the past two years including the infamous computer programming series. Currently studying Engineering at Cornell, Andres is basically interested in increased model rocket legalization and more public recognition of the link between the technological aspects of model rocketry and professional rocketry.

**Doug Ball**, NAR 9338 I first joined the National Association of Rocketry in 1967. In 1968 I co-founded the Mansfield Aeronautics and Space Association (MASA) section with Mr. Robert Hagedorn. With Robert Hagedorn, we won the Reserve National Team Championship; and in 1970 we won the National Team Championship.

I am currently engaged in doing the drafting for LAC member Chas Russell's *Scale Pak* project. I am also a member of the Standards and Testing Committee under Dr. Gerald Gregorek. I want to be an active member of the Leader Administrative Council.

**Trip Barber**, NAR 4322 I have been a rocketeer for nine years and a NAR member for eight. My first competition activity was NARAM 10; since that time, I have participated in or organized several regional, area, and section meets as the 1970 president and 1971 treasurer of the MIT Model Rocket Society. I was the chairman of the 1970 and 1971 MIT Technical Conventions, and am the NAR Massachusetts Department Head. At our 1971 Technical Convention, I introduced the practice of printing a summary of all R&D contest entries, something that I would like to do for NARAM R&D if I am elected.

**Mark Barkasy**, NAR 5038 Presently working in LAC on commercial film list for availability to sections and possibly members. Also working on feasibility of permanent official NAR slides and/or films.

I am attempting a BS degree in Aerospace Engineering at the University of Alabama. Also trying to form local section at the University.

I was in complete charge of the model rocketry display of our AIAA chapter for Engineering Day, April 28.

**Edward Bergmann**, NAR 9136 Edward Bergmann is a student in Aerospace and Systems Engineering at Boston University. Former president of one of Pascack Valley's districts, and past president of several clubs. Mr. Bergmann's interest is in reaching out to the individual rocketeer and making him feel a part of the NAR through activities which emphasize the individual rather than his section.

Research and development is the name of the game to Ed. He developed several computer simulations of rocket flight back in the days when Malewicki's equations were new to model rocketry. His work includes applications of mathematical optimization techniques to rocketry. Ed's current project involves the linking of a computer to a wind tunnel to accumulate and rapidly reduce data to a usable form and ultimately to control testing.

Readers of *The Model Rocketeer* will get to know Mr. Bergmann better through his column on R&D, co-authored with Daniel Ruvin.

**Wanda L. Boggs**, NAR 13833 As a member of the Tri-City Cosmotarians, I have been an active participant as club newsletter editor, head of data reduction on the range, and the club correspondent to "NAR Club Activities" in *The Model Rocketeer*. I am also responsible for contacting club members via telephone on such matters as club meetings, workshops, and launches.

As a present member of LAC, my projects include tabulating the responses to the questionnaires and re-editing the *NAR Section Manual*. My goals on LAC include gaining wider recognition of rocketeers outside the East Coast and to help gain Junior members the right to vote.

**George Dibos**, NAR 13466 Presently president of MRRA--Midwest Model Rocket Research Association, Kansas City. Involvement with model rocketry spans nearly a decade (he grew up with the hobby).

Has been competitive individually, and has extensive experience directing contests as well as other events (demonstrations, workshops, etc.). Originator and editor of *Reaction*, MRRA's newsletter which enjoys wide distribution throughout the U.S.

Has successfully interested various civil and military agencies in the benefits to be gained in support of model rocketry.

Consistently strives for efficiency, perfection in all areas of endeavor. He believes in the goals and principles of the NAR, and attempts to propagate these ideals. Section members depend heavily on his leadership, reliability, and control of their group.

George considers LAC one of the most ideal organizations to help the NAR continue to expand and improve; to continue its vital role as the foremost agency in model rocketry.

**Andrew S. Elliott**, NAR 7419 I have been a NAR member for over five years and have been to three NARAMs and three MIT Conventions. While a member of the NAR-HAMS section, I devised and organized the first WAMAR-VA meeting. I edited the club newsletter, *ZOG 43*, for two years, during which it received the Outstanding Newsletter award. I am now a student at MIT, and am doing production work for *Model Rocketry* magazine. This allows me to keep in steady contact with advances in rocketry both in and out of the Association.

**Oscar L. James, III**, NAR 15058 I am 19, attending Grayson County College, and have five years of modroc experience. I have participated in numerous local meets as well as the NAR sanctioned Texas State Championships. I have cofounded three modroc clubs, presiding in each,

and now belong to the Sulphur River Section. I have taught model rocketry and related subjects to the cadets of the Sherman-Denison Squadron, National Aerospace Program.

I can attend all LAC meetings that do not substantially interrupt my college schedule as well as serve my own area.

**Marvin Lieberman**, NAR 6750 Model rocketeer and NAR member for the past seven years. Steel City Section President 1969-1970, Executive Vice-President 1968-1969. Co-chairman 1971 Pittsburgh Spring Convention. Co-owner and operator of Astro-Communications Company. Attended NARAMs 8 through 10. Attended Pittsburgh Conventions 1 through 6 and MIT Conventions 2 and 4. Have worked closely with many former LAC members and have attended several LAC meetings.

**Richard Malecki**, NAR 11144 Fourth year in the NAR and sixth year in model rocketry. Started and was first secretary of the Xaverian Rocketry Club, editor of the club newsletter and presently club leader advisor. Competed in all types of contests including NARAM 10 and won third in Eggloft at NARAM 11. Have attended all four MIT Conventions and assisted as discussion leader at the fourth MIT Convention. Presently a member of the LAC and director of the LAC program to help form more NAR clubs throughout the nation.

**Chris Pocock**, NAR 10206 I became interested in model rocketry in the fall of 1966 and joined the NAR shortly thereafter. I was interested in easing Washington state model rocketry codes. This indirectly led to my appointment as Washington State Dept. Head in July of 1969. My interest and concern for the hobby shifted into the field of communication. Within my first year as State Head I corresponded with many individuals and clubs in the state, the division, and the rest of the country. This year I created the still fledgling newsletter, *The Western Center of Pressure*, for the Pacific Division.

**Charles N. Russell**, NAR 10920 I live in Hilliard, Ohio and am the Vice-chairman of the C.S.A.R. I have been in modrocketry for five years and in the NAR for over three. I have competed successfully in many area and regional

meets, NARAM 11, and I won the National Leader Championship at NARAM 12. I am a member of the 1970-1971 LAC and also serve as a member of the Standards and Testing Committee. I am currently heading the LAC's *Scale Pak* project.

**Brian Skelding**, NAR 17500 I am president of the Pascack Valley NAR Section. I was formerly secretary and am now president of the Bloomfield-Glen Ridge District of Pascack Valley. I am now working with the Elizabeth (N.J.) Police Community Relations to promote model rocketry. I am assisting the LAC in the project to create sets of technical slides, and, if elected to LAC, will work to create a qualifying point or meet system for NARAMs.

**Connie Stine**, NAR 1300 I have been a NAR member for the past nine years. Before I became interested in competition, I worked in the NAR office sorting mail, answering inquiries, etc., and am aware of what work is involved.

For the past six years I've been a member of the YMCA Space Pioneers. I have attended NARAM 8 through 12 and was Junior National Champion at NARAM 10.

For the past two years I've been actively taking part in demonstrations and the section newsletter, *Emanon*. Presently I'm competing as a team with my sister and working with the pink book revision committee.

**Alan Stolzenberg**, NAR 6314 Active NAR member for past seven years. Junior Reserve Champion at NARAM 11. Secretary-Treasurer of Steel City Section for past three years. Chairman of newsletter, contest and records, and membership committees at various times. Chairman of Pittsburgh Spring Convention for past three years.

**Harold Youngren (Guppy)**, NAR 13005 I have been involved with model rocketry for nine years and an NAR member for three. I am currently a student at MIT and do occasional work for *Model Rocketry* magazine. Thus I am close to new developments in the hobby. I have been a member of the Annapolis Association of Rocketry and NARHAMS and am presently secretary of the MIT Model Rocket Society. My present interests lie predominantly in research and development and boost glide.

-----  
(detach here)

My choices for the 1971-1972 NAR Leader Administrative Council are the following: (Check seven names)

- |  |   |   |
|--|---|---|
| <input type="checkbox"/> Charles Andres  | <input type="checkbox"/> George Dibos       | <input type="checkbox"/> Chris Pocock       |
| <input type="checkbox"/> Doug Ball       | <input type="checkbox"/> Andrew S. Elliott  | <input type="checkbox"/> Charles N. Russell |
| <input type="checkbox"/> Trip Barber     | <input type="checkbox"/> Oscar L. James III | <input type="checkbox"/> Brian Skelding     |
| <input type="checkbox"/> Mark Barkasy    | <input type="checkbox"/> Marvin Lieberman   | <input type="checkbox"/> Connie Stine       |
| <input type="checkbox"/> Edward Bergmann | <input type="checkbox"/> Richard Malecki    | <input type="checkbox"/> Alan Stolzenberg   |
| <input type="checkbox"/> Wanda L. Boggs  |   | <input type="checkbox"/> Harold Youngren    |

Signature \_\_\_\_\_ Date \_\_\_\_\_

Attach address label here

LAC Ballot  
c/o Bob Mullane  
34 Sixth Street  
Harrison, New Jersey 07029

On May 1 the Trustees held a meeting at NASA Goddard Spaceflight Center in Maryland. The following are just a few of the developments to come from that meeting:

- It is an FAI rule that anyone interested in international competition must have an FAI sporting license. To obtain one, send \$2.00 with your name, address, age division, and NAR number to NAR headquarters. The \$2.00 pays for the license, for handling, and some of it goes into a fund being set up to pay for U.S. team expenses.
- A committee to formulate selection criteria for international competitors and to choose the U.S. team has been set up. Anyone who wants to be considered must have an FAI license by NARAM 13 as well as at the time of competition. Candidates must be over 14.
- Anyone wishing to set FAI records must have an FAI license at the time the record is set (effective as of June 1).
- There will be a special meeting of the NAR at NARAM 13 at which the amendment to the NAR By-Laws published in this issue will be proposed.
- There will be a Trustees' meeting at NARAM, probably on Monday night.

The minutes of this meeting, at which, I am told, much was accomplished, will be published in a future issue of the *Model Rocketeer*.

### FAI COMPETITION LICENSE

The following ruling has just been received by NAR Headquarters from the Federation Aeronautique Internationale (FAI). An FAI Sporting License is required of each NAR member who wishes to be considered for selection to the USA World Championships Model Rocket Team or to apply for an FAI Record.

The FAI Sporting License is available from NAR Headquarters at a cost of \$2.00 a calendar year. Profit from license sales will be used to support the FAI Team.

**ONLY MEMBERS HOLDING THE FAI SPORTING LICENSE WILL BE CONSIDERED FOR FAI TEAM SELECTION.**

## Application for FAI Sporting License

**NAR Headquarters  
P.O. Box 178  
McLean, Va. 22101**

NAR# \_\_\_\_\_ \$2.00 enclosed

Name \_\_\_\_\_ Age \_\_\_\_\_

Street \_\_\_\_\_

City \_\_\_\_\_ State \_\_\_\_\_ Zip \_\_\_\_\_

*Persons under 14 years can not participate in FAI World Championships but are eligible to set FAI Records.*

### NEWLY CERTIFIED ENGINES

The Standards and Testing Committee has announced that the Cox D8-0 and D8-3 model rocket engines have been safety certified. They also were contest certified as of May 15. These two Cox engines can now be used in sanctioned competition.

### NEW CONTEST BOARD PHONE

Any questions concerning Contest Sanctioning activities should be directed to Dick Sipes at (301) 864-8017. All questions concerning Record Attempts should be directed to: Howard Galloway, at (301) 987-4395.

### NAR MAILING LIST

NAR H.Q. reports that many sections have written McLean requesting the names and addresses of individual NAR members in a particular state. Headquarters, realizing addresses are an important section asset in terms of issuing invitations to mod roc demonstrations, symposiums, conventions, contests, and section meetings, has set up the following procedure for requesting mailing tapes. This offer is limited only to sections. The section request for addresses must be signed by the group's senior advisor. Zip codes of the area desired must be included. A two dollar minimum fee must be paid with the request. Two cents for each address over 100 will be charged.

### TOP POINTHOLDERS IN THE NAR

The following are the top pointholding individuals, teams, and sections in the NAR as of April 19, 1971:

#### TOP TWENTY INDIVIDUALS--DIVISION A

Name (NAR number)	Points
1. Kennedy, John (18526)	187
2. Gordon, Jeff (12036)	184
3. Simons, Roderick (17754)	184
4. Wurster, Christopher (18525)	156
5. Bailey, Steven (15618)	151
6. Irwin, John (18761)	130
7. Eastman, Tom (14521)	118



8. Starks, James (17691)	112	3. Larson, Don (16306)	314
9. Peters, Lawrence (15559)	107	4. White, Terry (11184)	310
10. Began, Tim (17931)	107	5. Lindgren, Alfred (11501)	282
11. Lindgren, Leslie (15237)	105	6. Bossong, Gary (14961)	270
12. Eastman, Eric (14522)	105	7. Medina, Jess (14147)	264
13. Rivera, Rodney (12550)	90	8. Randolph, Jon (15496)	236
14. Biedron, Robert (16085)	87	9. Eastman, Daniel (14412)	233
15. Buzzard, Thomas (15698)	84	10. Walton, Lewis (14211)	190
Hopkins, Mark (15577)	84	11. Scinto, Greg (5589)	170
16. Hadley, Bob (19704)	78	12. Hendricks, Dave (17743)	170
17. Mechtly, Kerry (16799)	76	13. Gunter, George (12865)	168
18. Penney, Benard (20164)	70	14. Feldmann, Karl (1136)	159
19. Lane, Alan, Jr. (18410)	60	Thayer, Robert (15521)	159
20. Clemens, Chris (12749)	45	15. Bailey, William (15523)	154
		16. Allen, Robert (16089)	142
		17. Worthen, James (7095)	141
		18. Lindgren, Shirley (13685)	132
		18. Werre, Raymond (14082)	132
		19. Powell, Taggart (12621)	129
		20. Pera, Ronald (15802)	126

TOP TWENTY INDIVIDUALS--DIVISION B

Name (NAR number)	Points
1. Jacobsen, Gary (12862)	426
2. Wargo, Mark (10371)	360
3. Hunter, Bart (12174)	344
4. Lindgren, Gregory (10677)	267
5. Scarborough, Michael (18524)	213
6. Bailey, Bill (14644)	210
7. Kerley, James (12091)	206
8. Setzer, Steve (16903)	198
9. Waznitski, Harry (13827)	189
10. Yung, Carroll (6319)	168
11. Mendel, Anthony (14339)	162
12. Smith, Clay (17776)	162
13. Krallman, Charles (15118)	158
14. Benson, Tammy (11761)	154
15. Day, Paul (12090)	150
16. Beecher, Steve (16745)	148
17. Rook, Chris (15082)	140
18. Goodwin, Richard (12786)	136
19. Burris, Tom (12650)	133
20. Sweet, Stephen (16914)	133

TOP TWENTY INDIVIDUALS--DIVISION C

Name (NAR number)	Points
1. Lindgren, Gary (10678)	408
2. Shay, Bruce (12117)	375
3. Chilcoat, William (13485)	322
4. Hinman, Cody (13671)	253
5. Dayton, Alan (17367)	252
6. Grosberg, Rick (17105)	216
7. Lane, John (12298)	195
8. Cohan, David (9419)	190
9. Clark, Kevin (10085)	189
10. Rasmussen, Russell (16334)	180
11. Beebe, Brad (14709)	160
12. Anderson, Brian (13020)	159
13. Mooney, Michael (12790)	151
14. Brown, John (19708)	150
15. Pommert, Jim (16908)	147
16. Cline, Brad (17114)	140
17. Johnson, Don (17727)	134
18. Ream, Thomas (9325)	132
19. Gunter, Jeff (12864)	130
20. Drake, John (7515)	129

TOP TWENTY INDIVIDUALS--DIVISION D

Name (NAR number)	Points
1. Stine, G. Harry (2)	496
2. Jacobsen, Arnold (12863)	381

TOP TWENTY SECTIONS

Section Name	Points
1. YMCA Space Pioneers	4653
2. Pascack Valley	2997
3. Metro. Area Rocket Soc.	1932
4. South Seattle Rocket Soc.	1822
5. Polaris	1438
6. Northglenn Mod. Rocketeers	1251
7. Fairchester	1188
8. Tri-City Cosmotarians	1006
9. NOVAAR	989
10. West Covina	822
11. Monroe Astro. Roc. Soc.	788
12. NARHAMS	743
13. N. Royalton Roc. Soc.	736
14. Laurel Area Rocket Society	725
15. Bethlehem Section	719
16. Delta-V NAR Section	686
17. T.I.R.O.S.	676
18. Birch Lane Rocket Soc.	666
19. Central Ill. Mod. Roc. Assn.	551
20. CSAR	550

TOP TWENTY TEAMS

Team Name	Points
1. Stine, Constance	461
2. Englund, Sven	395
3. Sipes, Richard	322
4. Englund, Laura	310
5. Medina, Tony	237
6. Seitz, John	210
7. Boggs, Ron	181
8. Rawlinson, Gary	165
9. Okesson	151
10. Johnston, Jeffery	146
11. Pearson, Chris	136
12. Kenworthy, Bill	126
13. Burzynski, Michael	124
14. Kasper, Jim	112
15. Stolzenberg, Alan	102
16. Barrowman, James	92
17. Kuhn, Craig	90
18. Butterworth, Leslie	80
19. Uthoff	77
20. Downey	67

**(Club Notes, continued)**

reported on the latest issue of *S.A.R.C. Spark*. In the drag race event Jeff Risberg took first place flying an Estes Shrike, Steve Risberg placed first in the Sparrow B/G event flying his FatCat to 66 seconds. First place in Class 1 PD went to Rick Toth for a 148 second duration with his Alpha, Steve Risberg topped the PeeWee Payload field with 1625 feet flying an X-Ray. In the Eggloft event Frank Moyer took first flying a Scrambler powered by three C6-5 engines to an 1175 foot altitude.

The latest issue of *Emanon* reports the results of the YMCA Space Pioneers section meet (SP-25). In the Hornet B/G event John Drake topped the field with a 98 second

duration. A. Jacobsen placed first in the Sparrow B/G event with an 85 second flight. John Drake took first in Class O Streamer Duration with a 60 second flight as well as winning the Class 1 Streamer Duration with 32 seconds. Mike Scarborough topped the Class O PD field with a 54 second duration. Next up on the Space Pioneers schedule are two Area Meets before NARAM.

A model rocket club has been organized in the Detroit, Michigan area. The Michigan Area Rocketeers Society currently has nineteen members, including two senior members, and is sponsored by the Tel-Star hobby shop. At the club's first launch on March 21st a total of 31 rockets, including an Estes Cin-

eroc, were flown. The club meets once a week, and launches are planned frequently. Interested rocketeers should contact the Activities Coordinator: Bill Beasinger, 5753 Audubon, Detroit, Michigan, 48224.

A new model rocket club is being organized in Batavia, New York. Any interested rocketeers in Genessee County and the surrounding area are invited to contact David Kloos, 9 Holmes Ave., Batavia, NY.

A new club has been organized in Camillus, New York. Interested rocketeers can contact Dana Peters, 109 Heather Lane, Camillus, New York 13031.

The latest issue of *Countdown*, letter of the Elkins Park Orbiters (Elkins Park, Pennsylvania), reports results of the March 6th contest between the Elkins Park Orbiters and the Warminster Rocket Research Society. In windy weather the Spot Landing event proved to be quite a challenge. The winning strategy was to underpower the bird and use a long delay charge so the chute was deployed just above the ground. Mike McGurrin took first place with his Midget landing it 27 feet from the target. In the Ostrich Eggloft event there was only one entry, the Streiker-Rains "Universal Booster" which was DQ'ed. The Warminster club topped EPO in Class 1 PD with Mike McGurrin taking first and Ray Parambo placing second. However EPO took the first three places in Swift B/G to give them a 62 to 37 victory over Warminster. Steve Shore topped the B/G field with 41 seconds on a Falcon. A "rematch" between the two clubs is planned for June. Interested rocketeers can contact the Elkins Park Orbiters at 409 Shoemaker Rd., Elkins Park, PA 19117.

A new NAR Section is being formed in Grand Rapids, Michigan. Interested rocketeers are asked to contact Kim Davidson (4133 Kentridge Dr. S.E., Grand Rapids, Mich. 49508).

# DEALER DIRECTORY



Hobby shops desiring a listing in the Model Rocketry Dealer Directory should direct their inquiries to Dealer Directory, Model Rocketry magazine, Box 214, Boston, MA 02123. Space is available only on a six month contract for \$18.00, or a twelve month contract for \$35.00, payable in advance.



**CALIFORNIA - Alhambra**  
THE BOX CAR  
Trains - Models - Rockets  
CRM-Centuri-Estes-Flight Systems  
128 West Main  
Tues. to Fri. till 9 PM Mail Order

**CALIFORNIA - Mt. View**  
Model Rocket Supplies  
SAN ANTONIO HOBBY  
417 San Antonio Rd.  
Sears Shopping Center

**CALIFORNIA - Whittier**  
Complete Selection  
of Model Rockets  
Estes-Cox-Centuri-MPC  
JACK'S HOBBYCRAFTS  
14710 E. Whittier Blvd. 90605  
Mon.-Thurs. 10-6, Fri. 10-9, Sat. 9:30-5:30

**CONNECTICUT - Bridgeport**  
Complete Rocketry Supplies  
Is Our Specialty  
Estes - Centuri - etc.  
BOB'S HOBBIES  
1542 Wood Avenue  
Bridgeport 06605

**DELAWARE - Wilmington**  
All Major Rocket Lines  
SIMPSON'S HOBBIES, INC.  
709 Foulk Road  
Wilmington, Delaware 19803  
Mail Orders Ph: 654-5022

**DELAWARE - Wilmington**  
HOBI-ART, INC.  
4713 Kirkwood Highway  
(302) 994-0281  
9:30 AM to 5:30 PM - Wed., Th., Fri. to 9 PM

**FLORIDA - Gibsonton**  
Save!!! All Brands  
Write for Lists and Discounts  
PAT'S PLACE  
P.O. Box 118  
7:30-6 Mon. to Sat. 813-677-6310

**GEORGIA - Smyrna**  
MILTON BRADLEY  
2152 So. Cobb Dr.  
Ph: 436-1581  
Open 10 AM to 6 PM - Mon., Th., Fri. to 9:30

**MARYLAND - Severna Park**  
PSYCHO-CERAMICS HOBBIES  
428 Ben Oaks Drive West  
Complete Model Rocket Supplies  
Centuri-Competition-DB Ind-SAI  
Telephone (301) 987-4395

**MARYLAND - Westminster**  
BOBBY'S HOBBY LOBBY  
65 E. Main St.  
Mon. to Sat. 10-9 Wed., Thur., Fri. 10-8

**MASSACHUSETTS - Cambridge**  
CROSBY'S HOBBY CENTER  
1704 Massachusetts Ave.  
(617) KI 7-4389  
9 AM - 5:30 PM Thursdays to 8:30 PM

**MASSACHUSETTS - Melrose**  
MIDDLESEX COIN, STAMP  
& HOBBY SHOP  
473 Main St.  
02176 662-8319

**MASSACHUSETTS - Walpole**  
Rocket Supplies by Fast Mail  
Estes, Centuri, MPC, Cox  
LAWCO SALES  
P.O. Box 244  
Walpole, Mass. 02081

**MASSACHUSETTS - Wellesley Hills**  
MR. WIZARD'S SCIENCE CENTER  
Complete Rocket Supplies  
239 Washington Street  
9 AM-6 PM (Th, Fr to 9 PM) 235-2486

**MISSOURI - St. Charles**  
Centuri-Estes-MPC-Galaxy-Cox  
Largest Rocket Shop in St. Charles City  
ST. CHARLES AEROSPACE HOBBIES  
559 First Capitol  
MWF 2:30-9, TTh 2:30-6 Sat. 9:30-6

**(From the Editor, cont.)**

We have a good number of "theorists" in our hobby today (not that we can't use more of them), but where are the experimentalists? Where is the data? Why do we let so many theories go unverified?

Even the simplest of our competition ideas go unchecked. For example: Does a tower launched model go higher than one using a pop-lug? Does a flop-wing boost higher than the same glider with the wings permanently open? Does a "turbulator" just forward of the base of a rocket increase its altitude? Simple questions, which can be answered by standard measurements of basic models. But the experiments have apparently not been done. Perhaps its not as glamorous as generating a hundred feet of computer output, but that printout is less useful than scrap paper unless we can be sure that it accurately reflects the behavior of an actual rocket.

The upcoming summer months offer an ideal opportunity for rocketeers interested in making a basic contribution to the hobby to get out their trackers, or stopwatches, or cameras, or other instruments and verify or disprove the theories which govern our current designs.

# Club Spotlight:

## Eastern Kansas Area Meet

The first large meet in the Kansas-Missouri area was held in Kansas City last March 28th, 1971. EKAM-1, the first Eastern Kansas Area meet, drew contestants, and spectators from St. Louis, Missouri, Kansas City, and Wichita, Kansas. The events flown were Class 1 Parachute Duration, Roc Eggloft, Design Efficiency, Ostrich Eggloft, and Scale. Following the opening launch of a Saturn V, Parachute Duration was begun. After the first few flights, it became apparent that more careful chute packing was necessary. The winning time was turned in by Michael Peterson of Kansas City with 168 seconds.

Next came Roc Eggloft mainly to show the crowd some big ones and to hold their interest. This event had several of the new Enerjet F's entered. Trackers reported slight difficulties in following the Enerjets because of the high acceleration, even with eggs, and very little smoke. A design new to most modelers was the Egglofter entered by George Dibos. George staged three D4's on top of three D6's. The flight was successful, although it weathercocked, and was good enough to take third place. First place was won by Mark Pemberton with 854 meters. Just 39 meters less and second place was the flight turned by Gary Cole.

The results for Design Efficiency were somewhat lower than anticipated probably because of winds that developed. Gary Raley of NARGAS (St. Louis) won the event with 72 points. In second place was the only female contestant, Janet Dibos, with 65 points. Janet's rocket, quite appropriately, was candy apple purple with pink flowers carefully painted on. The best flight was actually turned in by CAP Capt. Larry Loos of the Group VII section with 75 points. However, it found its way into a nearby tree which unfortunately was marked for removal by the park officials. Upon returning shortly afterwards, Capt. Loos discovered that not only was his model missing, but the entire tree was as well.



Air Force Photo by Sgt. J. Skarsten  
CAP Capt. Larry Loos shows his Design Efficiency model to Janet Dibos, whose purple and pink rocket took 2nd place in DE. Larry's rocket ended up in a model eating tree after turning in the best flight.

Ostrich Eggloft provided some impressive flights for the crowd and anxious ones for the contestants. The event was plagued with DQ'ed flights resulting mainly from broken eggs. The winning altitude was by Tom Spiker's entry with 626 meters, and only 9 meters behind was the second place flight by Mark Pemberton.

The last event of the day was Scale. A fine Saturn IB entered by Lytle Norton won first place and Tom Kuechler of NARGAS finished second with his Saturn 1 which was modified from the Saturn IB. The Scale flights were all qualified and marked the end of the meet on a successful note.

The meet was covered by two of the local television stations and the city newspaper. The crowd, probably seeing model rockets for the first time, went away impressed with what they saw and with all the equipment used to run the contest. As a result of EKAM-1, Model Rocketry has been given a big boost in the Mid-West.

### RESULTS OF EKAM-1

#### Class 1 PD

- |                               |      |
|-------------------------------|------|
| 1. Michael Peterson           | 2:48 |
| 2. Gary Raley (NARGAS)        | 2:06 |
| 3. Harold Mayes (MRRA)        | 2:01 |
| 4. Larry Loos (Group VII CAP) | 1:55 |

#### Roc Eggloft

- |                              |       |
|------------------------------|-------|
| 1. Mark Pemberton (MRRA)     | 854m. |
| 2. Gary Cole (MRRA)          | 815m. |
| 3. George Dibos (MRRA)       | 256m. |
| (no other qualified flights) |       |

#### Design Efficiency

- |                        |               |
|------------------------|---------------|
| 1. Gary Raley (NARGAS) | 72m./n-sec.   |
| 2. Janet Dibos (MRRA)  | 65 m./ n-sec. |
| 3. Lytle Norton (MRRA) | 61 m./ n-sec. |
| 4. Michael Peterson    | 47 m./ n-sec. |

#### Ostrich Eggloft

- |                              |             |
|------------------------------|-------------|
| 1. Tom Spiker (MRRA)         | 626 meters. |
| 2. Mark Pemberton (MRRA)     | 617 meters. |
| 3. David Norton (MRRA)       | 266 meters. |
| (no other qualified flights) |             |

#### Scale

- |                          |             |
|--------------------------|-------------|
| 1. Lytle Norton (MRRA)   |             |
| Saturn IB                | 769 points. |
| 2. Tom Kuechler (NARGAS) |             |
| Saturn IC                | 685 points. |
| 3. Gary Cole (MRRA)      |             |
| IQSY Tomahawk            | 485 points. |

### SECTION TOTALS

- |                                 |          |
|---------------------------------|----------|
| Mid-West Rocket Research Assoc. | 360 pts. |
| NAR Gateway Arch Section        | 100 pts. |
| Group VIII Civil Air Patrol     | 4 pts.   |

**NEW JERSEY - Absecon**  
AERO-TRAIN HOBBY HOUSE  
12 Station Avenue  
Mon.-Fri: 12 Noon-9PM Sat. 12 to 6PM

**NEW JERSEY - Edison**  
Complete Rocket Supplies  
EDISON CYCLE SHOP  
238 Plainfield Avenue  
Estes, Centuri, MPC, Bo-Mar, SAI, etc.

**NEW JERSEY - Jackson**  
JACKSON HOBBY SHOP  
Complete Rocket Supplies  
Centuri, Estes, Flight Systems  
New Prospect Rd.  
Open 7 days/week 364-3334

**NEW JERSEY - New Brunswick**  
Estes, Centuri, MPC  
STEVE VARGA'S HOBBY SHOP  
57 Easton Ave.  
(201) 545-7616  
Daily 10AM-7PM Closed Sunday

**NEW JERSEY - Princeton**  
Complete Rocket Supplies  
MPC-Centuri-Estes-Space Age Ind.  
NASSAU HOBBY  
142 Nassau St. Princeton, New Jersey

**NEW JERSEY - Wayne**  
TOTOWA HOBBY SHOP  
131 Boonton Road  
Rocketry isn't our only Hobby!  
Open Sundays is only one hobby section 696-5170

**NEW YORK - Uniondale**  
Biggest and the Best with the Most  
Estes & Centuri  
CARD & CRAFT  
1004 Front St.  
Mon., Thurs., & Sat. 9-6 Fri. 9-9, Sun. 10-3

**OHIO - Cleveland**  
NATIONAL HOBBY, INC.  
5238 Ridge Rd.  
749-4750  
Daily to 6PM Mon. & Fri. to 9PM

**OHIO - Upper Sandusky**  
Complete Rocketry Supplies  
THE ROCKET SHOP  
640 Skyline Drive  
6 to 9PM 294-1322

**PENNSYLVANIA - Monroeville**  
LORESKI'S HOBBY SHOP  
"Miracle Mile" Shopping Center  
10AM - 9PM (412) 372-5155

**PENNSYLVANIA - Scranton**  
THE DEN, INC.  
Everything in Rocket, Planes, Crafts  
Route 6, Scranton-Carbondale Hygh  
10AM to 10PM 7 Days a Week

**PENNSYLVANIA - Sunbury**  
SCHRADER BROS.  
470-472 North 4th St.  
8 AM to 10PM (717) 286-6841

**UTAH - Ogden**  
Rocket Motors Our Specialty  
Mail Orders Welcome  
ROCKET TECHNOLOGY CORP.  
432 25th Street  
Ogden, Utah 84401

**WASHINGTON - Seattle**  
Rocketry for the Northwest  
Nationally Known Brands  
CAMPUS HOBBY CENTER  
4738 University Way N.E.  
Open Thurs. Eves. Phone: LA 5-2222

**CANADA - Toronto, Ontario**  
Canada's only exclusive rocket shop  
Home of the Canadian Rocket  
Society - Complete facilities and  
hobby consultants  
THE SCIENCE SHOP  
137 Yonge St. Arcade

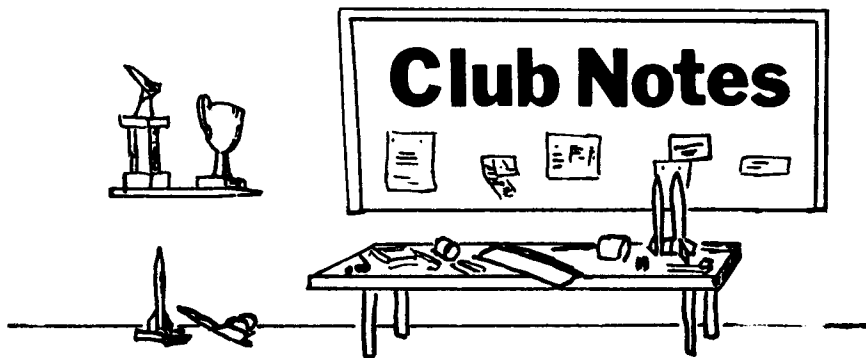

A new model rocket club is being formed in the Cincinnati/Hamilton County area of Ohio. Eventually the club plans to charter as an NAR Section. Interested rocketeers should write to Robert V. White, 1559 Meredith Dr., Apt. 5, Cincinnati, Ohio 45231.

A new model rocket club is being formed in the Cape Cod and South Yarmouth, Massachusetts area. Interested rocketeers should contact Peter Deibeinois, 81 Regional Ave., South Yarmouth, MA 02664.

"The Tallahassee Flying Technicians," a model rocket club, is being organized in the Tallahassee, Florida area. Rocketeers interested in joining this club should contact Lee Norris, 700 Stiles Ave., Tallahassee, Florida 32303.

The latest issue of *the Voyager*, newsletter of the Annapolis (Maryland) Association of Rocketry reports results of their March 14th "Practice Shoot." Three events were flown in this unofficial contest flown

on a clear day with no wind. Jack Anderson, a new member of the club, took first in Spot Landing; John King topped the B/G field; and Alan Marshall won the Drag Race.

The next major event on the AAR schedule is an Area Meet set for June 19th. Rocketeers in the Annapolis area wishing to join the club should contact AAR, co. Hank Greco, Senior Advisor, Box 217A, Davidsonville, MD 21035.

New Jersey's Pasack Valley Section has held elections for officers. Results in the latest issue of *Impulse* are: Brian Skelding, President; Bob Kranker, Secretary; and Karl Feldman, Treasurer.

Any rocketeer in the Worcester, Mass. area interested in forming a club is invited to contact Brian Donabedian, 24 Englewood ave., Worcester, MA 01603.

Richard Ralston of Indianapolis, Indiana is attempting to organize a rocket club in that area. Interested rocketeers should contact him at 3530 Pixley Ct., Indianapolis,

Indiana.

A model rocket club is being formed in Toronto, Canada. Interested rocketeers should contact Jim Dickson, 120 Jameson Ave., No. 304, Toronto 150, Ontario, Canada.

The Monterey Association of Rocketry and Experimentation is attempting to start a California or Western Newsletter. Other clubs and individuals in California are invited to contact Jack Aiello, 899 Jefferson st., Monterey, CA 93940.

A new club has been organized in Tulsa, Oklahoma. The East Tulsa Research and Development Association is seeking new members. Interested rocketeers should contact Doug McLure, 7887 E. Jusper, Tulsa, Oklahoma 74115.

A model rocket club has been organized in the Ravenswood, West Virginia area. Interested rocketeers should contact Ed McCray, Box 91, Route 1, Ravenswood, W. Va. 26164.

A new club is being formed in the Dorona, Oregon area. Eventually the club plans to charter as an NAR Section. Interested rocketeers age 12 or older are invited to contact Rod Hudson, at 942-2292.

The Manhasset, New York Police Boys Club has organized a model rocket club. Boys 10 to 14 from Manhasset will assemble model rockets under the guidance of Ronald Burrough of the Manhasset High School.

A rocket club has recently been organized in Redding, Connecticut. They have a six position launch rack, launch panel, firing table, tracking and communications system available for club activities. Rocketeers in the Redding area can contact Kevin Nolan, RD No. 2, Great Oak Lane, West Redding, Conn. 06896 for more information on the club.

Students at the George Washington School in Elizabeth, New Jersey are being exposed to an impressive array of model rockets owned by Patrolman James McDaniel, a community relations officer who has spent a lot of time with children at the school, responded enthusiastically when Principal John Richardson suggested he demonstrate his rockets to the students. Now he plans to supervise them in the construction of model rockets, and hopes to expand the classroom expand into a citywide club.

A model rocket club is being formed in the Sedalia, Missouri area. The group eventually plans to charter as an NAR Section. Rocketeers interested in joining this club should contact Tommy Cave, 1007 W 7th, Sedalia, Missouri 65301.

Rocketeers in the Metairie, Louisiana interested in forming a club are asked to contact Robert Flores, 751 Homestead Ave., Metairie, LA.

Results of the ARC-1 contest held by the SARC club of Allentown, Pennsylvania are (Continued on page 46.)



Photo by Eric Max

The NOVAAR Section of the NAR, located in Northern Virginia, has been quite active this spring. Club members have been developing designs for the new Rocket/Glider competition, such as the swing-line (left) by Jess Reeback. At right is Eric Max's "Big Waah" on its first flight at a recent NAVAAR launch. Rocketeers interested in joining NOVAAR should contact Paul Shelton, 3698 Oak Street, Fairfax, Va. 22030.

# BULLETIN:

**NEW MPC MINIROCS SHATTER RECORDS  
IN FIRST APPEARANCE AT NAR SANCTIONED MEET!**



Now . . . model rocketry is a whole new thing! So is the model rocketry records book . . . as witnessed by the latest gathering of the pros in a NAR sanctioned meet. Out went a whole batch of 1/2A, A, and B engine records. In are the new Miniroc records. Minirocs have just changed the name of the game in rocketry. Miniroc rockets . . . Minijet engines . . . both are the result of a major technical breakthrough. Minijet engines are up to 46% lighter while packing the same power! This means the Miniroc rockets can be lighter, slimmer, and have less drag than ever before. So whether you're going for the championships . . . or just wanting to start off in rocketry with championship equipment, you're Miniroc material.

# minirocs™

**THE NEW CHAMPIONSHIP ROCKETS**



MODEL PRODUCTS  
126 GROESBECK HIGHWAY  
MOUNT CLEMENS, MICHIGAN  
48043

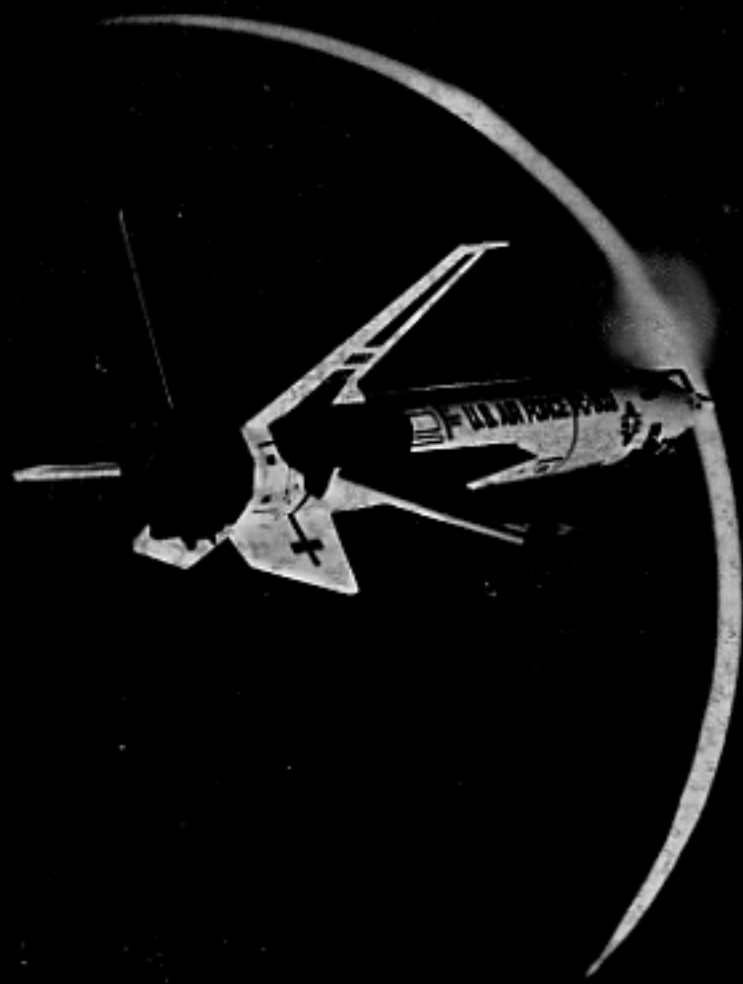

Step into the real world of space

*see your hobby dealer*



A SUBSIDIARY OF DAMON

DEPT. 31-M / PENROSE, COLORADO / 81240