

MODEL ROCKETRY

JANUARY 1971

60¢

The "BAT"
Saucer Wing B/G



The Journal of Miniature Astronautics
Incorporating THE MODEL ROCKETEER

COMPETITION B/G
WING CONSTRUCTION

TRI-SEC II
CONTEST REPORT

SOUND MOVIES
FROM MODROCS

HOW TO START
A CLUB

BOOST/GLIDER
STABILITY EXPLAINED

FOXMITTER II
MICROPHONE MODULE

BUILD THE
"ARROW-HEAD"

Plastic Conversion SPACE CLIPPER

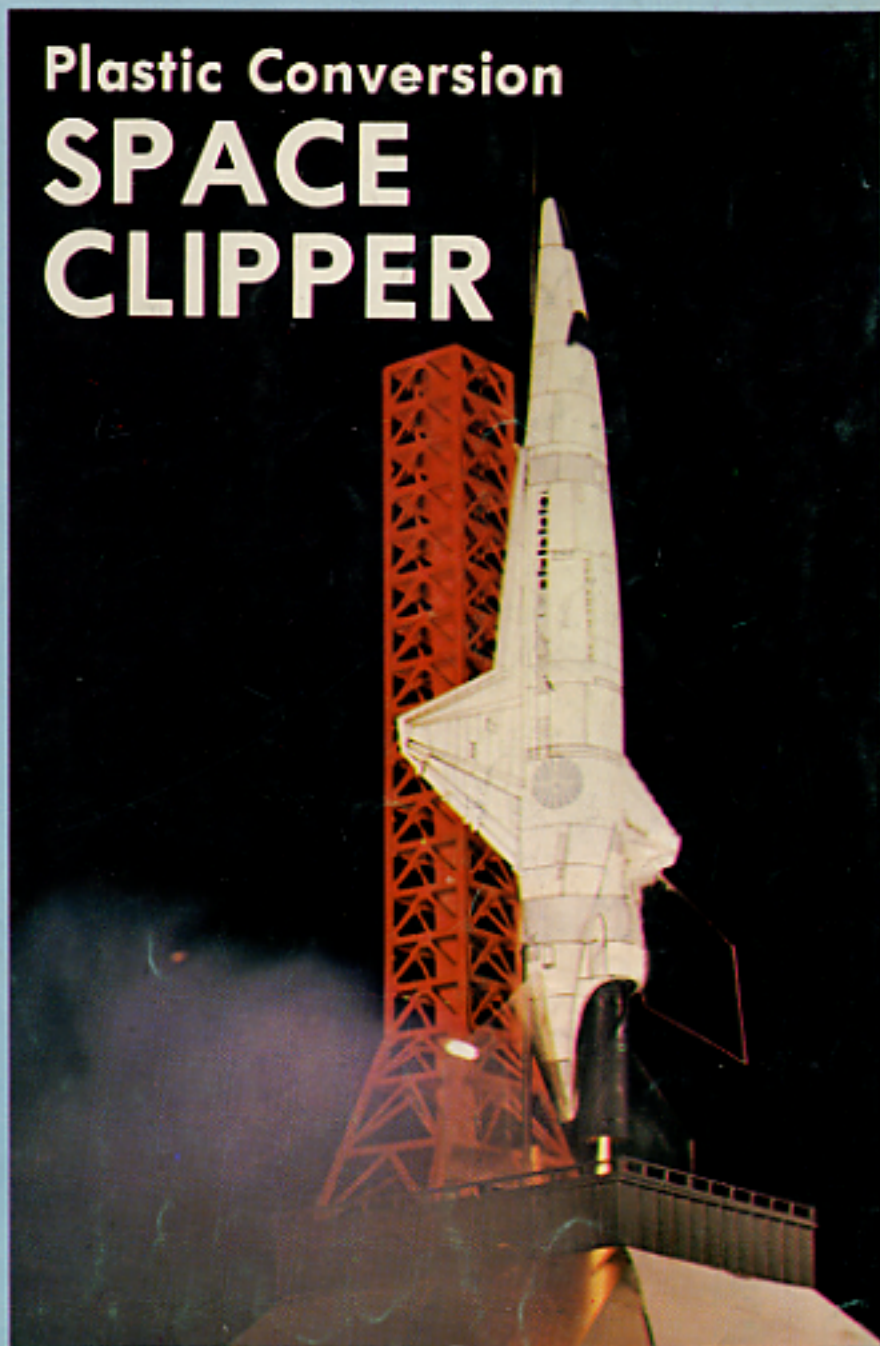

HERE'S WHY- YOU SHOULD BUY..

Centuri

ROCKET ENGINES

In continuous comparing and testing of CENTURI Engines with other brands, CENTURI rated consistently higher in performance and reliability. All CENTURI Rocket Engines carry the NAR Certification of Safety.

From our brand new 20 acre Rocket Engine Plant (some 10 miles south of Phoenix) comes a new breed of Rocket Engines.

CENTURI manufactures more model rocket engine types than any company in the world. The wide range of selection allows you to pick the exact power and time delay needed for each specific flight application.

*plus ...
with every engine,
you receive ...*

FREE!
SURE-SHOT®
IGNITERS



Now included FREE with CENTURI engines ("A" through "C" type), the new SURE-SHOT 2 Igniters. Simple to install! Positive, quick ignition of your engine every time! SURE-SHOTS also give you reliable simultaneous ignition of "clustered" engines. Complete instructions for use included.



NEW "CODE BAND"

Now you can see the "engine code number" easily, at a glance - no matter which way the engine is turned. Code number is continuously repeated, in crisp, clear printing around the entire engine.

ALL NEW LABEL

Sharper, clearer, easier-to-read! No more faded out or blurred labels. Label color indicates correct use of engine:

GREEN for single stage.

PURPLE for upper stage or featherweight models.

RED for booster engines.

All CENTURI Engines are
NAR* SAFETY CERTIFIED
*National Association of Rocketry
Standards and Testing.

NEW TRACKING SMOKE

New higher density tracking smoke makes visual tracking easier - makes flights more spectacular! Newly formulated smoke issues from engine nozzle all the way from "burnout" to "ejection".



All CENTURI Rocket Engines are available now - at your favorite hobby store or order direct. Write today for big new 1971 Rocket Supplies Catalog - 25¢. Learn how to join the CENTURI AEROSPACE TEAM - FREE! Complete details with catalog. Write to CENTURI, Dept. M-11, P.O. Box 1988, Phoenix, Arizona 85001.

Centuri

CENTURI ENGINEERING COMPANY, PHOENIX, ARIZONA 85001

Model Rocketry

Volume III, No. 4
January 1971

Editor and Publisher George J. Flynn
 Managing Editor Gordon K. Mandell
 Technical Editor Douglas Malewicki
 Assistant Editor Robert B. Singer
 Assistant Editor Robert Parks
 Business Manager Thomas T. Milkie
 Distribution Manager Steven Glines
 Technical Correspondent George J. Caporaso

This month's cover shows a flight converted Aurora "2001 Space Clipper" lifting off from a converted Countdown Saturn-V pad. Complete conversion plans for the "Space Clipper" will be found in this month's *Escape Tower* beginning on page 12. (Cover photo by George Flynn.)

From the Editor

The editorial on this page one year ago called for the establishment of more Conventions and regional gatherings to promote direct communications among rocketeers. Within the last few months the hobby has seen two different types of "Conventions" which seem worthy of comment.

This first of these — a "Mini-Convention" sponsored by New Jersey's Pascack Valley NAR Section — was a one day gathering of rocketeers from New Jersey and surrounding states. The idea in scheduling the comparatively small, one day affair was to promote a freer exchange of ideas on the discussion groups than is possible in the "classroom atmosphere" of the larger conventions. Questions from the participants were encouraged in all four of the seminars on R&D, scale, drafting, and advanced R&D. By restricting the conference to one day, Pascack Valley eliminated the need for much of the advance planning of meals, hotel rooms, transportation, etc. which is associated with the larger conventions. Their success with the "Mini-Convention", or more properly the "Northeast Regional Technical Symposium", demonstrates the value of such opportunities for direct communication among rocketeers.

At the same time, in Ohio another regional gathering — the Mid-Ohio Model Rocket Workshop — was taking shape. This conference, put together on three weeks notice at the suggestion of a local school principal, was sponsored by the Scinto-Darby NAR Section with the assistance of three other local clubs. About 80 new rocketeers and 40 experienced modelers attended this one day workshop. They heard presentations on competition design, B/G design, and other topics, and the beginners were supervised in a workshop construction session.

The participants in both of these conferences can testify to their success. These clubs have worked out a way to achieve many of the communications benefits of the larger conventions with much less work on the part of the sponsoring club. The effective use of one day conferences on an area or statewide basis as a supplement to the regional conventions should be of great benefit to the development of the hobby.

Contest Report: TRI-SEC II 8
 On the scene coverage of the first major competition to be flown under the new NAR Sporting Code. The revised Eagle boost/glide, and Open Payload events were on the schedule.
by George Flynn

Flying the Aurora "2001 Space Clipper" 12
 This month's "Escape Tower" contains detailed plans for the flight conversion of the Aurora plastic model of the Space Clipper from the movie "2001: A Space Odyssey."
by Bob Parks

Competition B/G Wing Construction 16
 Stronger, lighter weight, and more smoothly finished B/G wings are possible using the "cut-out" method.
by Jerry Jones

How to Start a Club 18
 In this first installment of our new "Club Corner", Bob Mullane describes the procedure for getting a club organized.
by Bob Mullane

The BAT: A Saucer-Winged Boost/Glider 19
 Complete plans for the BAT, a unique boost/glider design. This unusual fly-for-fun model will attract plenty of attention the next time you go out flying.
Designed by Bill Schmidt

Sound Movies From Your Modroc 23
 A report on the first successful attempt to obtain sound movies from a model rocket in flight. Using an Estes CINEROC and a Foxmitter Microphone Module the attempt took place at NARAM-12
by George Flynn

A Microphone Module for the Foxmitter II 24
 Plans and schematic for the Foxmitter microphone module used with the first successful sound/movie experiments.
by Richard Fox

Boost/Glider Stability Explained 26
 A simple report explaining pitch, roll, and yaw stability for a boost/glider.
by Bob Parks

Regular Features

From the Editor	1	New Product Notes	29
Letters to the Editor	2	Modroc Calendar	37
From the Launching Pad	5	Club Spotlight	39
Reader Design	15	Club Notes	40

The Model Rocketeer (National Association of Rocketry) 30

Worldwide newsstand distribution by Eastern News Distributors, Inc. 155 West 15th Street, New York, New York 10011. Hobby shop distribution by Kalmbach Publishing Co., 1027 North Seventh St., Milwaukee, Wisconsin 53233.

Second class postage paid at Boston, MA and at additional mailing offices.

Model Rocketry magazine is published monthly by Model Rocketry, Inc. 595 Massachusetts Avenue, Cambridge, MA 02139.

Subscription Rates: US and Canada \$6.00 per year \$3.50 for 6 months, 60 cents for single copy; Foreign \$11.00 per year, \$6.00 for 6 months, \$1.00 for single copy. For change of address please notify Subscription Department, Model Rocketry, Box 214, Astor Street Station, Boston, MA 02123 at least 6 weeks in advance. Include former address or mailing label with the new address.

Material submitted for publication should be accompanied by a self-addressed, stamped envelope if return is desired. Model Rocketry can assume no responsibility for material lost or damaged, however care will be exercised in handling. Articles accepted for publication will be paid at the rates current at the time of publication. Letters, contest information, news, announcements, etc. are assumed to be submitted gratis.

Undeliverable copies, notices of change of address, subscriptions, and material submitted for publication should be submitted to Model Rocketry, Box 214, Astor Street Station, Boston, MA 02123

Printed in USA

©Copyright 1971 by Model Rocketry, Inc.



LIQUID FUELED ROCKETS

ROCKET PLANES □ JET PLANES

Check out Vashon's aerodynamic fleet for '70! Authentic high performance single, and multi-stage model rocket kits, rocket plane kits and ready-to-fly jet planes. All use a unique non-flammable propellant that requires no special permit or license. Send 25c for illustrated catalog today!

VASHON INDUSTRIES, INC.
Box 309 G, Vashon, Wash. 98070



For A Great
SCIENCE FAIR PROJECT

FOXMITTER Model Rocket Transmitter Kit and Accessories

For our new catalog,
send 25¢ to:
Astro-Communications Co.
3 Coleridge Place
Pittsburgh, PA. 15201

Membership service especially for teachers and students. Includes 8 packets of assorted aviation and space materials.

WRITE NOW FOR INFO
National Aerospace Education Council
806 - 15th St. NW
Washington, D. C. 20005

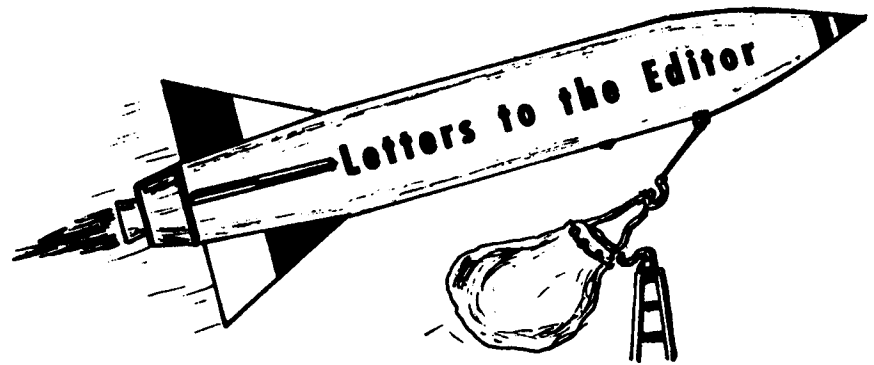

Plastic Modeling

A few months ago I wrote you a letter concerning the Hawk Jupiter-C conversion article. You published my letter in the April 1970 issue and recommended some other plastic models that were suitable for conversion. Since then I have converted an Aurora X-15 and a Monogram Saturn V. Both of these models are great for display (with very good detailing) and are also very impressive in flight.

The only disadvantage in converting plastic models is the weight involved. In both of the models which I converted it was necessary to add several ounces of weight to the nose to make them stable enough for flight (without the use of clear plastic fins). My X-15 weighs about 5 ounces, while the Saturn V weighs about 11.5 ounces. I use a B6-4 engine in the X-15 and a D13-3 in the Saturn-V.

Mike Curtis
Decatur, Georgia

Vostok Ejection Seat

In regards to the conversion plans for the Revell Vostok capsule in the September 1970 issue, here are plans for an operating ejection seat. A small piece of a plastic straw is cut off and used for the guide for the spring assembly in the seat. The spring assembly is a small piece of "tree" from the

kit that can fit into and be glued to a spring from a ballpoint pen. A small hole is drilled in the bottom of the seat that will let the "tree" slide out but not the spring.

The spring assembly is then inserted into the straw, the "tree" slid through the hole, and the straw glued in place. The seat can then be cemented together. A paper clip is shaped like a "C" at the top and an "L" at the bottom, angled 90° away from each other.

The seat is pushed into place and held in by the "C" shaped hook on the end of the clip. A piece of parachute shroud is attached to the "L" shaped portion and the other end is fastened to the inside of the upper stage rocket.

When the capsule and the equipment module are ejected, the string is pulled and the clip releases the seat. The clip is automatically pulled from the capsule so the modules fall separately. A piece of shroud line should be attached to the hatch and the capsule so the hatch does not fall freely.

Joseph Keppel, Jr.
Bethlehem, PA

PD Performance

I was just noting in the September issue the application of Finnagle's Law to rocketry that: "A parachute will always get caught in the only tree around." It has been

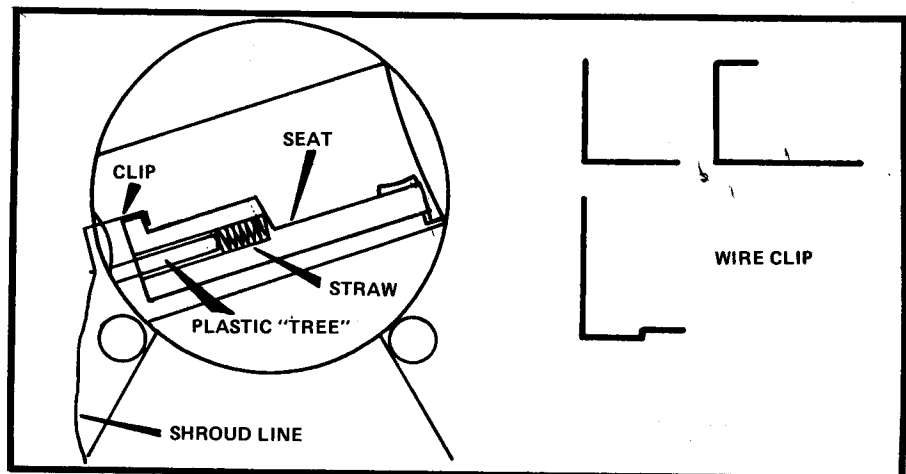

The Vostok Ejection Seat, as described by Joseph Keppel, uses a spring mechanism actuated by the engine ejection charge.

noted before, for instance in the Tri-City Cosmotarians' newsletter *Tracking West* as the beast *Rocketus Eatemupus*, and will continue to be noted as it will continue to happen. It has happened to me, as my Scrambler booster would tell had I recovered it. On reflecting on this, I believe there is a reason.

Parachute Duration buffs love thermals. Fine, but thermals may be responsible for a peculiar disturbance causing a funnel toward anything above the ground. A clump of trees is sufficient, or a single large one.

A thermal is simply rising air. Now when air rises, other air must come in from the sides to fill the void. A tree will slow or stop any currents from one side, so that the thermal centers over it. Where it centers, it rises fastest. But faster moving air exerts less sideways pressure, so the chute glides smoothly into the tree. Wind, which the duration buffs hate, may be the only thing keeping their chutes out of the trees (which they also hate). However, such thermals are not present, or at least not strong enough, except on warm afternoons. Morning flyers better find another reason.

There is one, if there is a wind. A bank of trees will disturb the wind for several hundred feet up, and a rapidly drifting rocket may stop drifting there, falling rapidly into the trap. So there!

Peter Clay
Eugene, Oregon

Russian Booster

Upon reading the Vostok article in September's "From the Launching Pad" I recognized the Soviet booster shown in the picture. I just recently read a book which contained a picture of this booster. The book is *Rockets* by S.E. Ellacot published by Criterion Books in 1961. I hope this information will help any scale modeler who is working on this rocket.

Mark Orthner, NAR 18133
Cherry Hill, New Jersey

Diamant Scale

While reading through the September 1970 issue of *Model Rocketry* the article about the International Contest - "Dub-nicky Maj" - caught my eye. In looking over the pictures of rockets, I became interested in the French Diamant entered by one of the Polish competitors. In one of your future issues I would like for you to publish an article showing how to build it.

Eddie Lee Martin
Knoxville, Tennessee

Models of the Diamant have been seen at several European model rocket contests. However, no one in the United States has been flying a model of this French booster. Perhaps no one in the US has plans. You can

TRANSMITTERS

Advanced model rocket telemetry systems incorporating the latest in integrated circuits and micro-packaging techniques. Systems include transmitter weighing 9/10 of a gram and occupying 8/100 of a cubic inch plus multi-channel systems.

Information 25¢

P.O. Box 477
Bozeman, Montana 59715

US, USSR

Slides, Prints

ROCKET PHOTOS

Write for our complete list of color and black and white rocket photos. These slides and prints are carefully selected for use as scale substantiation data. Send \$1.00 for your choice for a Mercury-Redstone 7, USSR Vostok, or Saturn V liftoff color transparency and complete photo list. (For the list only, send 25¢ and a stamped, self-addressed envelope.)

Rocket Equipment Co.
Dept. A, 10 Mulberry Ave.
Garden City, N.Y. 11530

M.I.T. TECHNICAL CONVENTION

APRIL 2, 3 AND 4, 1971

AT THE MASSACHUSETTS INSTITUTE OF TECHNOLOGY

KEYNOTE: THE TECHNIQUES OF MODEL ROCKET ENGINEERING

FEATURING

- * BANQUET AND THREE OTHER MEALS
- * COMPUTER DEMONSTRATION
- * INTERESTING LAUNCH
- * 5 DISCUSSION GROUP PERIODS, OFFERING: Launcher Systems, Competition Design & Strategy, Low Drag Design, Propulsion Techniques, Boost Glide Design, Instrumentation, and many other topics
- * OPEN R&D PRESENTATIONS CONTEST (by age groups)
- * ROCKETRY MOVIES (bring your own)
- * SCIENCE FICTION MOVIE

CONVENTION FEE: \$12.50, HOTEL ROOMS EXTRA (\$15.85 quad)

CONTACT:

Trip Barber, MIT Model Rocket Society, MIT Branch P.O. Box 110
Cambridge, Mass. 02139

Application Deadlines

MARCH 15 with hotel room
MARCH 22 without hotel

be sure that if we come across a good set of Diamant plans, we will publish them.

NART-1 Coverage

I must mention one outstanding article in the August 1970 issue of *Model Rocketry* — the coverage of NART-1. It is an excellent report, much better than the usual dry statistics. The article gives the idea that model rocket meets are *fun*, as well as stiff competition. Let's have more of this kind of reporting.

Douglas Pratt
Seneca Falls, N.Y.

Modroc Guidance

For approximately 13 months I have been working on a model rocket guidance system. Currently I am working on a gyroscope of the "super flywheel" configuration (*Popular Science*, August 1970) mechanically linked to drag flaps on the rocket airframe. The gyroscope would be mounted on gimbals, and motor driven.

I have already made one "string driven" gyroscope (without gimbals or drag flaps) but it has insufficient running time (10 to 15 seconds) to be used in a rocket.

Andy Judkis
Pittsburgh, PA

Paper Rockets

After reading your coverage of the Canadian Convention (*MRM*, October 1970), I decided to do the same thing Max Yablonovitch did — build and fly a paper rocket. So I rolled a body tube around an engine (to get the proper size) and I rolled my own conical paper nosecone. I made some elliptical fins out of cardboard.

I was quite surprised to find that no additional noseweight was necessary for stability, though it was necessary to put the 12" chute pretty far forward. I launched the model with an A8-3 engine. It went so perfectly that I just couldn't believe it! An A8-3 almost put it out of sight. It went about 550 to 650 feet straight up.

Alan Cantor
Montreal, Canada

Washington State News

Have you received any information or the Washington State Model Rocket Championships held in Spokane in August 1970? Or how about the Ocean Shores Invitational held in July of 1970? Along with four senior members of the Columbia Model Rocket Club, I attended all of the summer meets in Washington, and we were curious if anyone had reported the results to

you.

Clubs from throughout the state of Washington and Canada were in attendance and provided excellent competition. In a nutshell, some of the more interesting events were as follows:

1. Saturn V (1/100th scale) — a scale event, judged on workmanship in construction of the large kit Saturn V's.

2. Payload Boost/Glide — a B/G duration event in the 10.0 to 25.0 nt-sec total impulse range, with all entries carrying a single one-ounce payload weight.

The latter event was flown for the second time in the state. There were three successful entries. The best time, 53 seconds, was turned in by a modified Manta using a C6-3 engine in a detachable power pod.

My entry flew successfully for 68 seconds, but was disqualified since the streamer burnt off the engine. It was a modified Sky-Slash type B/G powered by an Estes D13-0 engine. A one-ounce payload was strapped on at the CG. At least it proved that a D-powered boost/glider carrying a one ounce payload could survive and turn in a respectable time.

Steve Watson, NAR 5472
Columbia Model Rocket Club
Vancouver, Washington

INTERNATIONAL COMPETITION

The first official results from International Competition held in Yugoslavia last September have been received by *Model Rocketry*. As reported last month, the U.S. team — consisting of Dr. Gerald Gregorek and George Pantalos of the Columbus, Ohio CSAR Section and Bryant Thompson, NAR Vice-President from Rantoul, Illinois — did not do too well. In the 5 nt-sec Parachute Duration event Prof. Radu N. Jon of Rumania took first with a duration of 1066 seconds. The winner in the 5 nt-sec Boost Glider event was Bojan Paraskevov of Bulgaria with a 290 second duration. In the Scale event, Otokar Saffek of Czechoslovakia took first place with 918 points for his fine Saturn V model.

For the United States, Dr. Gregorek turned in a 270 second flight in the Parachute Duration event, for an 11th place among the International competitors. His 217 second flight in the boost/glide competition was good for a 5th place in that event. George Pantalos flew the only U.S. scale entry, a model of the TAD used to loft the Tiros weather satellite from Vandenburg last January. Unfortunately it was underpowered, and did not make a qualified flight.

Complete coverage of the International Competition is expected to be ready for publication in next month's issue of *Model Rocketry*.



Photo by J. Divis
U.S. Team Members Dr. Gerald Gregorek (left) and George Pantalos prep George's scale model of the Thrust Augmented Delta at the International in Yugoslavia.

FROM THE

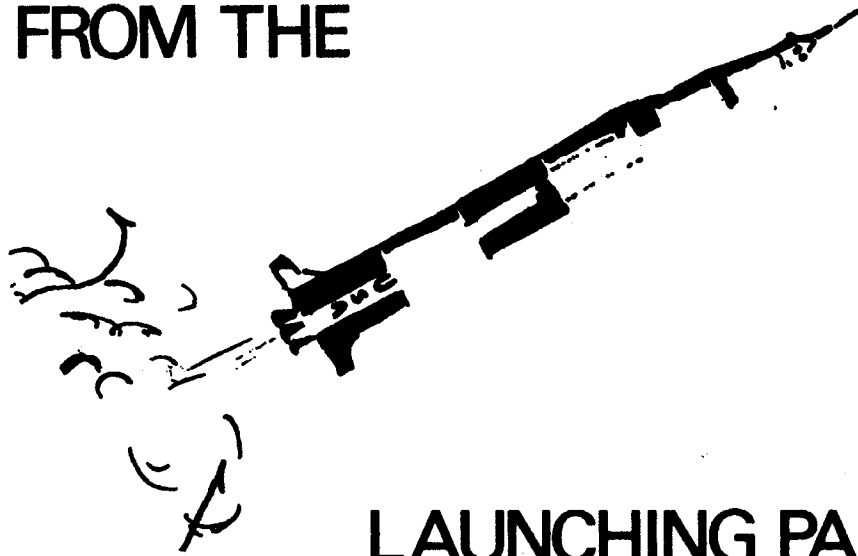

LAUNCHING PAD

If you're a U.S. rocketeer who thinks you have it bad after last year's price increases, just take a look across the border into Canada. There are *no* model rocket manufacturers in Canada. All modroc supplies and engines must be imported from the U.S., and large "import duties" must be paid. These duties really up the cost of model rocketry in Canada.

For example, three A5-2 engines cost only 90¢ here, but in Canada the same engines sell for 60¢ each (\$1.80 for three) — and the Canadian engines are sold without igniters. Looking over the price list from one of Canada's leading model rocket hobby shops, I note that the Centuri Nike-Smoke sells for \$5.40 up there, compared with \$3.50 here. The Saturn-V kit, \$16.95 in the U.S., sells for \$28.50.

However, the recent successes at the first

Canadian Convention in Montreal and the first Canadian Regional Competition in Alberta prove that the hobby is developing in Canada. There is quite a bit of interest, and the next few years should see a dramatic growth of model rocketry in that country.

For those of you who were interested in the "Funny Meet" reported in last month's *Model Rocketry*, we've obtained a copy of the rules under which the contest was flown. Reprinted below are the "Un-Pink Book" rules which governed this "unique" contest. Give it a try!

We've received quite a few interesting comments about the Foxmitter since it first appeared in print. However Walter Raudonis

"FUNNY MEET RULES"

- The NAR Safety Code will apply as will the general rules of good sportmanship, good judgement, and good fun. Ribbons will be awarded on the basis of funny points earned as follows:

Place	Points	POINTS		Total
		Compet.	Wt. Fact	
1st	10	10	10	1000
2nd	6	10	10	600
3rd	4	10	10	400
Qual. Fl.	2	10	10	200

(The 10 point weighting factor applies to each event.)

- The National Association of Rocketry Contest Board stipulates that an NAR member competing in the "Funny Meet" will neither be penalized for nor credited with his "funny points."

3. EVENTS

- OPEN UN-SPOT LANDING** — Consider a circle of radius 25 feet. The contestant whose rocket (nose cone) lands closest to the circumference shall be the winner. Unlimited engine.
- CLASS I NON-PARACHUTE DURATION** — The contestant with the shortest flight shall be declared the winner. The entry must, in the opinion of the judges, fully deploy a 12" parachute before landing. Minimum engine 1/4A.
- SWIFT BOOST/GLIDE NON-DURATION** — The winner shall be the entry which achieves a gliding flight of the minimum total duration. A engine only.
- NON-SCALE FLIGHT** — The contestant who achieves a stable flight with the least rocket-like object, in the opinion of the judges, shall be declared the winner. Rocket-like objects will be disqualified. The entry must make a safe recovery. The safety officer, as always, may reject any entry. Unlimited engine.
- NON-DRAG RACE** — The contestant achieving two out of three of the following objectives will be declared the winner:
 - Last movement on the rail,
 - Maximum Altitude,
 - Minimum Flight Duration.

The event shall be flown in heats, two rockets at a time, with the winner advancing to further stages of the competition. Unlimited engine.

(Reprinted from THE VOYAGER, newsletter of the Annapolis Association of Rocketry)



Get in the winner's circle!
Fly Competition Model Rockets!
CMR
Box 7022 MR
Alexandria, Va. 22307
Send 20¢ for our new 1971 Catalog

ROCKET RECOVERY TRANSMITTERS

Model PRS-100 six transistor transmitter introductory price only \$16.95 complete.

Each transmitter receivable on two frequency's
FM Broadcast band & 150 mc PS band
Power 100 mw or less — No license required
Total weight with battery & antenna 1 1/2
Send 25¢ for latest brochure

PRIME RECOVERY SYSTEMS
P.O. BOX 84, LANSING, MICHIGAN, 48901



P.O. BOX 424
WILLOUGHBY, OHIO 44094
DEPT. MR

SPACE & ROCKET MODEL KITS

We carry MPC, SPACE AGE IND., REVELL, AURORA, LINDBERG, HAWK, VASHON IND., AMT, L.M. COX — 25¢ for Catalog & FREE Color Print of THE APOLLO 11 Lift-Off — Complete Mail Order Service —

P D

1/4 MIL

ALUMINIZED MYLAR CHUTE MATERIAL

For duration competitions use the lightest, thinnest chute material available. This 1/4 mil mylar is aluminized on one side for easy visibility. You can fit a 36 inch chute in an 18 mm standard tube. One 56 inch by 10 foot sheet is enough for two 56 inch diameter competition chutes, or three 36 inch chutes. Order today!

Only \$5.00 per sheet

Rocket Equipment Company
Dept. RS
10 Mulberry Ave.
Garden City, New York 11530

SPECIAL OFFER!

Beautiful, full-color photograph of the Apollo 7, Saturn 1B liftoff of October, 1968



This magnificent photograph of a most historic moment in the history of spaceflight was obtained by Model Rocketry editor George Flynn from an advance position not accessible to most Kennedy Space Center visitors. Showing the moment of liftoff, this 7 by 8 inch full-color print will make an inspiring addition to the album of any space enthusiast.

Full-color copies of the photograph, which is reproduced in black and white above, may be obtained by sending 50¢, or \$1.00 for 3, to:

Saturn Photo
Model Rocketry
 Box 214
 Boston, Mass. 02123

MAIL ORDER HEADQUARTERS

DON'T BE LEFT OUT OF AMERICA'S NEWEST, MOST EXCITING HOBBY!

MODEL ROCKETRY SUPPLIES ARE AS CLOSE AS YOUR MAIL BOX ----

ESTES, CENTURI, MINI-MAX, FLIGHT-SYSTEMS, MPC, COX, AMROC, SAI, CMR, SEMROC, MITS, ENERJET, VASHON, COUNTDOWN....

SEND 50¢ AND WE'LL MAIL YOU OUR LATEST CATALOG

orange blossom hobbies, inc.

1975 N.W. 36th STREET dept. MR
 MIAMI, FLORIDA 33142



of Nashua, New Hampshire reports what has to be the most unusual experience. Twice he has launched Foxmitters, only to have the payload section land in a swamp. Since the

Foxmitter quits transmitting when under water, he's lost both Foxmitters. Perhaps Dick Fox should get to work on a sonar version of the transmitter.

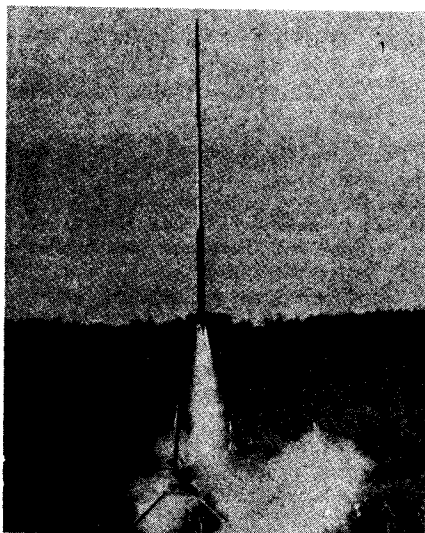

Bob Parks' Tail-Tail 10 lifts off powered by an F7 and three D18's.

After finishing up the article on the "Tail-Tail 10", the 10 ft. rocket described in last month's *Escape Tower*, Bob Parks decided to see what the rocket could do with a little more power. He removed the D-engine mount and replaced it with a mount for an FSI F7. Three new FSI D-engines were attached outside the tube as strap-ons. If you add up the propellant weight you'll find that its just under the 4.0 ounce maximum limit... in fact it's under by more than 0.3 grams or 1/100 of an ounce).

The flight proved the strength of the Tail-Tail 10. Though it was designed to be powered by a single D, it withstood the acceleration of an F and three D's. The boost was perfect, and it was easy to track all the way through apex... four engines put out quite a bit of tracking smoke. Unfortunately, the F7 failed to eject the chute, and the Tail-Tail 10 was shortened somewhat in the landing.

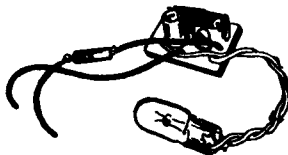

**BLINKIN'
 BEACON**

Model Rocket Tracking Light

An electronic flasher of very small size that produces a brilliant white light for help in tracking or following the flight of rocket models. Kit includes complete instructions for assembly and using your Blinkin' Beacon.

\$2.95



At your local hobby shop, or by mail from Space Age Industries, 714 Raritan Ave., Highland Park, New Jersey.

Initial results are in from the August and September "Reader Surveys." Just about everything seems to be equally popular, with not strong trends emerging. In the August issue the *NART-1 Coverage* and the *Flop-Wing B/G* articles were far and away the leaders on the forms you returned. The *Bio-1 Payloader* and the second part of the *RD-107 Vostok Astroscale* article ran close for third. The *Fox Temperature Sensor*, *Titan III M Semi-Scale*, and the *Boeing Wind Tunnel* plans were also highly rated.

In the September issue the *Foxmitter Accelerometer Module* ran first, with the *USAF Falcon Scale* and the *Dove III Flop-Wing B/G* construction articles running a close second. The *Revell Vostok Plastic Conversion* ran forth, while *PAR-1*, *Dubnicki Maj*, and the *BIO-1 Payloader* tied for fifth.

Keep those "Reader Survey" forms coming in. Your responses are the only way we can tell what you want to see in *Model Rocketry*.

This month we start a new regular column in *Model Rocketry*. The "Club Corner" by Bob Mullane will draw on his experience as former Pascack Valley President to guide new clubs through the initial

organization effort, publishing a newsletter, running a contest, and all the other little things that are easier if you learn through someone else's mistakes rather than your own. Let's hear some feedback from new clubs, so we can tell if features such as the *Club Corner* are of interest. And while we're on the subject, thanks go to William Fortier of New Bedford, Massachusetts for preparing the logo (that's the artwork on the column heading) for the *Club Corner*.

We have received quite a few letters asking what's happened to Gordon Mandell's *The Wayward Wind* column. Right now, Gordon is preparing the illustrations for *Topics in Advanced Model Rocketry*, a book to be released late this year by the M.I.T. Press. *The Wayward Wind* will resume in June as soon as the illustrations for the book are completed.

George

WHAT'S YOUR FAVORITE ARTICLE THIS MONTH?

Vote here for your favorite articles. List them in order – the most-liked first, etc.

- 1.
- 2.
- 3.
- 4.
- 5.
- 6.
- 7.
- 8.
- 9.

Clip this section out or use a facsimile. Paste on a postcard or enclose it in an envelope and send to:

Reader Survey
 Model Rocketry Magazine
 Box 214
 Boston, Mass. 02123

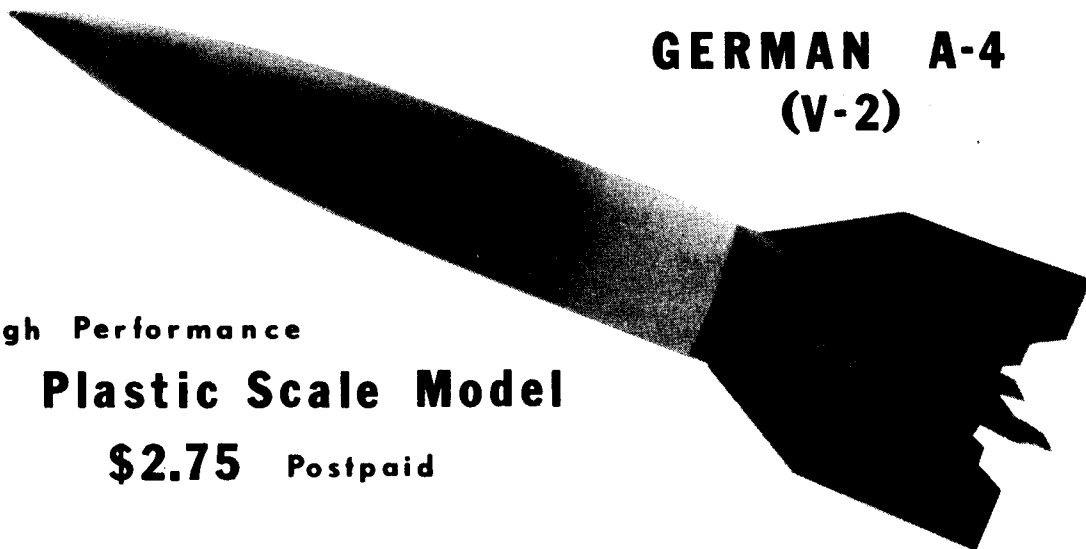

**GERMAN A-4
(V-2)**

High Performance
Plastic Scale Model
\$2.75 Postpaid

ROCKET TECHNOLOGY Corp.

P.O. BOX 3011, OGDEN, UTAH 84403

Eagle Boost/Glide and open payload were the feature events at The First Eastern Regional to be flown under the new competition rules.

TRI-SEC II

by George Flynn

TRI-SEC 2, the first Regional competition in the state of Delaware, was hosted by the New Castle Gemini Section on the September 11-13 weekend. Rocketeers from Delaware, Maryland, Pennsylvania, New Jersey, Connecticut, and Maryland were invited to participate in this first large meet to be flown under the new NAR Sporting Code. With the ECRM Hawk B/G disasters still fresh in mind the Eagle B/G event, on the Tri-Sec schedule, was awaited with some anxiety. Also on the schedule were Class 0 Altitude, Open Payload, Scale, and Class I Parachute Duration.

The decision to fly Open Payload and Eagle B/G gives some idea of the size of the Gemini field — large! It had to be large with those events on the schedule. Tri-Sec was flown from the "Sand Pits Launch Facility," an open field about 2000' by 4000', covered with rocks and brush but no trees, and located just across the highway from the motel.

All the competing clubs cooperated in providing range support personnel and equipment. The Gemini trackers, Centuri

Skytracks, were used. The launch system and pads were the Goddard built NARAM-10 equipment supplied by NARHAMS. The Annapolis Association of Rocketry, as has become custom at meets in their area, supplied the range communications equipment and manned their Range Store.

The first rocket off the pad, just about an hour behind schedule, was a demonstration flight of a Vashon Valkyrie one stage bird — with a perfect flight to about 100 feet.

Class 0 Altitude was the first event of the competition. Tracking was excellent, though there was a light cloud background, with many of the high and fast flights closing. In fact about 75% of the Class 0 models closed! A number of broken shock cords were saved from DQ's when the rocket bodies "glided" to a safe recovery after separation. The trend towards shorter and shorter towers got a few rocketeers in trouble when their Class 0 birds left the 12 to 18 inch tall towers and tumbled end over end into the sky. These short towers just will not work when there is any kind of a

wind blowing in the launch area, though they might be a good idea in calm air when the disturbing forces are smaller.

For the first time in recent years there was a two-stage model flown in Class 0 Altitude — in fact there were two of them. John Ormachel's bird, with ½A's in both stages, was DQ'ed when its booster engine ejected. Rick Ferris fared better with his two-stager with a tracked flight to 110 meters. But the performance of the two-stage models couldn't match that turned in by the standard one-stagers. The best flight, to 200 meters, was turned in by Steve Kranish. Dana Coffin took first in A Division with 164 meters, while Joel Bilbo placed first in C/D Division with 154 meters.



The Open Payloaders all looked the same — like Estes Farside Kits — powered by a D in each stage. But with 60 nt-sec total impulse and a light cloud cover it was too much for the trackers. Only a lucky few were tracked.



The Biggs family had a different idea ... make the upper stage large enough to assure a track. This colorful five foot Open Payload model, powered by three D's, just couldn't be missed.

Open Payload, being flown for the first time under the new rules using only two rather than four standard one ounce payloads, was flown next. The new rules called for new designs, and two different design strategies were immediately apparent. The first few rockets to leave the pad were all 3-stage D-powered birds. They flew straight and stable, . . . right into the base of the clouds to go untracked. Mark Mercer and a few other designers came up with a more successful strategy, considering the weather. Mark flew a single-stage, F100 powered model which, though only capable of half the altitude of the 3-stage D vehicles, stayed below the clouds and was tracked to 385 meters. That flight was good enough for a third place in the C/D Division.

It was tempting to take off the first booster, and fly a planned 3-stage D as a two stager, but that puts it under the minimum total-impulse limit for the Open Payload category. Only one rocketeer, Tam Joines, managed to get a closed track in the A Division with a flight to 382 meters. David Klousner took first in B Division with 334 meters, while the Kennedy-Gibbs Team placed first in C/D Division with 641 meters. The Kennedy-Gibbs D-B-D three-stager was one of the few three-stage birds to be successfully tracked.

The weather was still overcast on Sunday morning, but there was no threat of rain. Scale qualification flights were the first order of business on the schedule. The modeling was not, *on the average*, up to that

seen at MMRR-70 and NARAM this year, but there were a few exceptional models. In the A Division Dan Bracciale captured first place with one of the best finished models done by a Junior in years. Flying a Mercury-Redstone, assembled from an Estes kit, the model was finely detailed, with the only obvious fault being a slight yellowing of the decals. In the C/D Division there was quite a competition between the Kuhn Team's Nike-Tomahawk entry and Frank Bracciale's Saturn V. Howard's data collection and attention to bolt details on the Tomahawk allowed him to edge out the finely done Saturn V in the final point totals. Scott Snyder took first place in B Division with an IQSY Tomahawk model.

Overall the scale flights were

TRI-SEC II Results

Class 0 Altitude

A Division	1st	Dana Coffin	164 meters
	2nd	Mark Hopkins	162 meters
	3rd	Michael Fusco	132 meters
B Division	1st	Steve Kranish	200 meters
	2nd	Peter O'Neill	193 meters
	3rd	David Shucavage	136 meters
C/D Division	1st	Joel Bilbo	154 meters
	2nd	Roy Rosenfeld	148 meters
	3rd	Barrowman Team	144 meters

Open Payload

A Division	1st	Tam Joines (no other closed tracks)	382 meters
	2nd	David Klousner	334 meters
	3rd	Randell Biggs	194 meters
B Division	1st	Scott Snyder	182 meters
	2nd	Kennedy-Gibbs Team	641 meters
	3rd	Shiela Duck	480 meters
C/D Division	1st	Mark Mercer	385 meters

Scale

A Division	1st	Dan Bracciale	Mercury Redstone
	2nd	Rodney Rivera (no other qualified entries)	Saturn-V
B Division	1st	Scott Snyder	Tomahawk
	2nd	Frank Burdick	Tomahawk
	3rd	Ira Weiss	Tomahawk
C/D Division	1st	Kuhn Team	Nike-Tomahawk
	2nd	Frank Bracciale	Saturn-V

Class I Parachute Duration

A Division	1st	Dana Coffin	170 seconds
	2nd	Dan Bracciale	*
	3rd	Tam Joines	*
B Division	1st	David Klousner	141 seconds
	2nd	John Ermachle	*
	3rd	Dave Lewis	*
C/D Division	1st	James Joines	412 seconds
	2nd	Kuhn Team	*
	3rd	Tom Milkie	*

Eagle Boost/Glide

A Division	1st	Tam Joines	48 seconds
	2nd	John King	*
	3rd	Dana Coffin	*
B Division	1st	Steve McGraw	135 seconds
	2nd	Scott Snyder	*
	3rd	Karen Calentiano	*
C/D Division	1st	Martin Smith	102 seconds
	2nd	Joel Bilbo	*
	3rd	Kennedy-Gibbs Team	*

Overall

A Division	1st	Tam Joines	135 points
B Division	1st	Scott Snyder	186 points
C/D Division	1st	Kuhn Team	120 points

(*No second or third place times were reported in this event.)

MARS-V Contest Report

Next Month in Model Rocketry

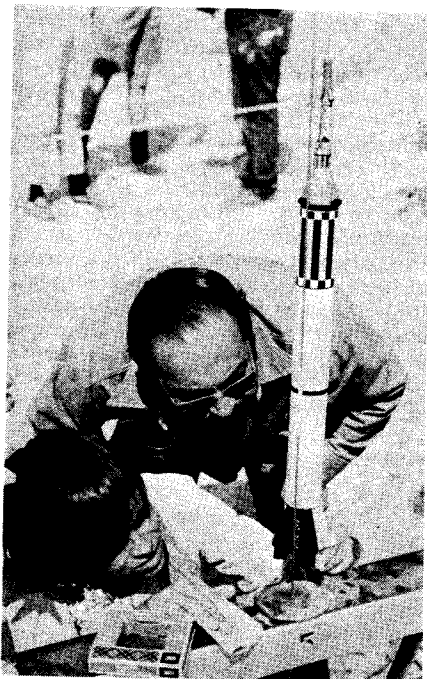

The winning A Division Scale model was a beautiful Mercury Redstone by Dan Bracciale. Assembled from the Estes Kit, the workmanship, especially on the tower, was excellent.

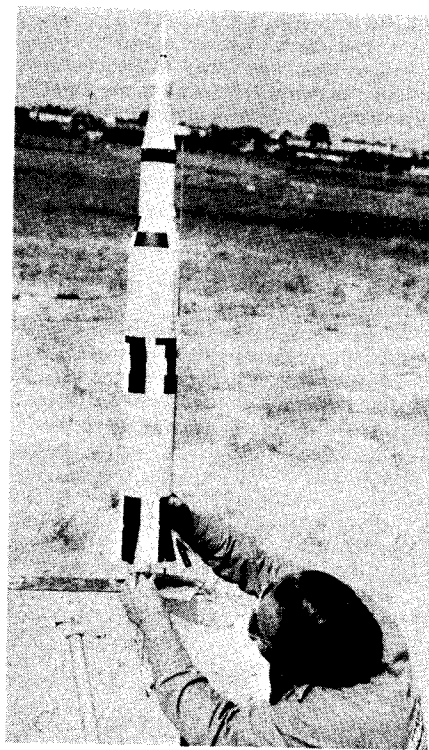

Frank Bracciale's Scale entry, a Saturn-V took a close second place in the D Division.



Howard Kuhn's Nike-Tomahawk, also flown at NARAM-12, took first. Among the small details included on this model were actual metal rivets and bolts on the Tomahawk payload and fin units and an insignia on the payload section.

disappointing, with many of the modelers failing to check whether their models would be *stable* before flying them. Since the new contest rules allow only *one* attempt to make a stable flight, and require disqualification from the entire event if a stable flight is not attained, there were a few DQ's. Recovery system failures, engine ejections,



It was an all new Maxi-Manta for the Eagle event. You can look right through the cut out, braced, and tissue covered wing on Howard Kuhn's new, and lighter, Maxi-Manta.

and two unstable Pershing flights by different models provided numerous lost points in this event.

Shortly before 1 P.M. the range was ready for Eagle B/G flying. The first rocket off the pad *held together*, but was DQ'ed when the glider failed to pull out of a death dive. Following the ECRM tradition, none of the first five B/G's were successful. All in all, though, a higher percentage of the Tri-Sec Eagles turned in qualified flights than did the Hawks at ECRM... so maybe some rocketeers are learning how to build high-powered B/G's that hold together... but the learning process is going painfully slow.

Carl Guernsey flew a unique glider — a flop-wing using a fixed C6-0 and another C6-0 in a pop-pod. Ejection of the pop-pod was to be used to actuate the wing deployment mechanism. Carl named the rocket the Total Disaster 1A... and it certainly was! The engine in the pop-pod failed to ignite, but the fixed pod engine lifted the B/G skyward. It didn't have a chance, since there was no way for the wings to extend. The idea was good, however, and the glider should work if Carl can just get *both* engines to ignite.

Bruce Blackistone finally succeeded in destroying the Disaster 10-B, erroneously reported to have been destroyed with its prang at NART-1. This time the wing shredded on the way up, thus eliminating any possibility of its being repaired for another flight (maybe?).

Just about everything was flown in the Eagle event. Several successful Thunder-Birds, three Maxi-Mantas that all failed, a styrofoam flop-wing, and numerous home designs. None of the flights were spectacular, as the results show. First place in A

Division went to Tam Joines with 48 seconds, while Steve McGraw took first in B Division with 135 seconds, and Mark Smith placed first in the C/D competition with 102 seconds.

The contest concluded with the Class I Parachute Duration event. Most of the rockets flown were reliable birds that had flown before in other events — there was very little that had been specially designed for this competition. The emphasis was on good altitude models, and there was no originality in chute design. The winners were Dana Coughlin in A Division with 170 seconds, David Klouser in B with 141 seconds, and James Joins in C/D with 412 seconds.

A series of manufacturers' demo launches followed the contest. Tag Powell of Space Age Industries flew the new SAI Tornado, a unique two-finned rocket employing spin-fins for stability. It flew straight up! The new SAI Falcon model was also demonstrated successfully. This rocket, featuring a hardwood nose cone, should be on sale early this month. From Competition Model Rockets, Howard Kuhn had a styrofoam wing Micro-Manta B/G strapped to the side of a booster rocket. Powered by a 1/2A, the parasite glider turned in a 50.6 second duration — not bad for a Hornet. Howard feels that the parasite glider may be the way to go in the small (Hornet) as well as the large (Eagle and Condor) B/G events. Competition Products was also represented at Tri-Sec. They were showing their new line of thin, polyethelene competition chutes.

Tri-Sec 2 concluded with the presentation of trophies and awards. Overall Tam Joines, Scott Snyder, and the Kuhn Team emerged the champions in A, B, and C/D Divisions respectively.

Big Shot



Check local ordinances before launching.

Seconds after liftoff your Cox Model Rocket hits 1800 feet. Then, the retro rocket pops the chute open, down it floats ready for another space shot. Model Rocketry is the most exciting new hobby in years. And now you can enjoy it minutes after leaving the store. Because Cox Rockets are ready to launch when you buy them. Great hobby to share with Dad.

Six authentic models to choose from, starting at under \$4. Apollo Little Joe II, Honest John, Nike Zeus, Astra Glider, the 21" Saturn 1B (shown) and Apollo Saturn V. See them today. Get in on the excitement. Send 25c for our "Handbook of Model Rocketry."



Also see our complete line of gasoline powered planes, cars and boats.

the Escape Tower

BY BOB PARKS



A Unique Plastic Conversion AURORA 2001 SPACE CLIPPER

Have you ever had a model that you just HAD to convert? Even if the model continually REFUSED to fly? Well, in my case, Aurora's kit of the Pan Am Space Clipper from the movie 2001, a Space Odyssey was such a model.

When the kit was first released several years ago, I bought the first one I saw, and my first reaction after opening the box was to test fit a rocket engine. It was a near perfect fit. Of course, conversion would be difficult because of the offset engine, and all the forward fin area. But ANYTHING will fly, given enough power and enough clear plastic fin material . . . or at least that's what I thought at the time. Now, finally, several kits, a few feet of clear plastic and innumerable C6-3's later **SUCCESS!!!!**

The intervening flights were in general very interesting. On the first few flights, the model was flipping so fast that it could hardly be seen. On one flight, the engine exhaust left a nice even burn mark, all across the bottom of the wing (the **BOTTOM** of the WING?????).

The thing seems to be pretty well tamed now. Construction is a bit tricky, but it's not too much more difficult than most plastic kit conversions.

To begin, cut the fuselage halves at the location shown in the drawing. Use the molded lines as a guide, and cut carefully. Glue the front portions together using plastic cement.

It will be necessary to either eliminate the engine room bulkhead or else cut a hole in it to clear the recovery system tube. I chose to eliminate it since it isn't really noticed, and it involves a lot less work. Tape the rear sections of the fuselage halves together, also tape the tail cove halves together. Glue the right tail cove half to the right fuselage half and the left tail cove to the left fuselage. Be careful to obtain the proper alignment since there are no alignment pins. Don't glue any of the right side parts to the left side parts. Remove the tape and separate the halves. The goal of all this is to obtain two full length body halves. (If you are using the engine room bulkhead, trim

out the bulkhead, leaving only a ring. Tape the parts together as before. Glue the ring to the right side parts only. The left side parts are used only for alignment at this time.)

Cut the BT-20 tube to the lengths shown in the drawing. (I have found the Competition Model Rockets body tube cutter to be perfect for cutting all of the unusual lengths of body tube that I seem to be using all of the time.) Glue the nose block into the 1/2" piece of BT-20 so about 3/8" of the nose block extends. About 1/2 ounce of clay nose weight should be stuffed into the inside of the nose at this time.

Tape the nose section to the right fuselage side. Insert the nose block into the front of the recovery system tube. The BT-20 is placed inside the nose section so the body tube joint is even with the rear of the nose section. The recovery system tube should be centered in the fuselage half. The paper tubes should now be glued to the plastic using tube type styrene plastic model cement. The short piece of BT-20 and the nose block are used to convert the plastic nose section into a normal type nose cone. Most of the trouble you just went through was to align the recovery system tube with the nose. Let everything dry thoroughly.

Now, it's time to install the engine mount. It will be necessary to notch the front of the engine mount tube so it can overlap the recovery system tube. The best way to find the proper location for the notches is by test fitting the tubes. The notches should be about 1/8" long. Mount a wire engine hook on the bottom of the engine mount tube. The front of the hook should be about 1/8" back from the end of the notches. Glue the tube in place, using plastic cement for the paper to plastic joints and white glue for the paper to paper joints. Make certain that the tube is parallel to the bottom of the body.

Fill the front of the engine mount tube and the back of the recovery system tube with at least a 1/8" thickness of tissue paper soaked with white glue. At this stage the assembly should pretty much resemble the one shown in the photo. Allow plenty of time to dry.

Now, glue the left fuselage half in place. All of the remaining white plastic parts should be added according to the kit instructions at this time. Insert an old engine casing into the engine mount tube, and then trim the tube so it is flush with the edge of the plastic.

The model is now ready for painting. I used an airbrush to spray on a couple of light coats of flat white paint. Details were painted in using a fine artists brush and flat aluminum and flat black enamel. All of the panel separation lines were traced using a #1 Rapidograph pen and india ink.

The cabin windows can be inserted from the front at this time. Also, glue the windshield in place.

Very carefully cut the fins from the heavy Estes clear fin stock. Test fit the fins, and trim where necessary to obtain the proper fit.

I used the following method of attaching the fins. First, the fins were aligned and taped in place. Tape was used on one side of the joint only. A smooth fillet of a fast

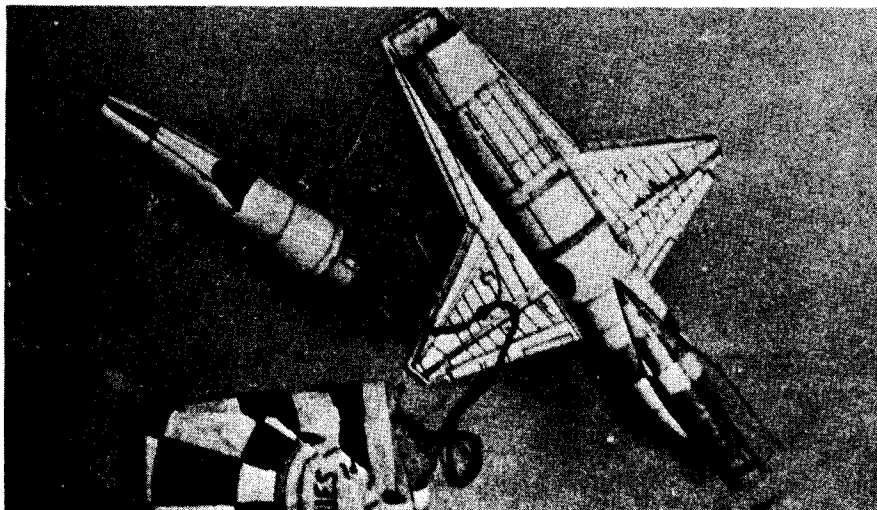

Without the addition of large plastic fins the Space Clipper might qualify as the "World's Most Unstable Rocket." However, there isn't much plastic working involved in the flight conversion. Aside from cutting the fins, the fuselage must be cut so the chute can eject. However, you should get quite a few difficulty points for the internal tube cutting and alignment.

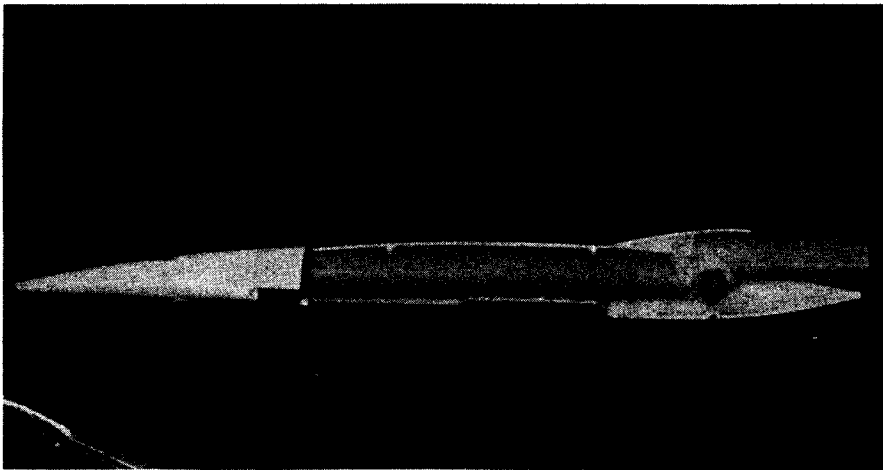

A complex arrangement of tubes for engine mounting, ducting, and recovery system housing, is mounted inside the Space Clipper. This is what the whole thing should look like before gluing the fuselage together. Alignment of the tubes is rather critical, but it shouldn't be too much trouble if you follow the plan with care.

hardening epoxy was applied. After the glue is completely cured, remove the tape and apply a fillet to the other side. The model is still rather sensitive to fin misalignments so be careful.

The recovery system should be a parachute at least 18" across. Installation is conventional and should cause no problems. The addition of a launch lug will complete your model.

Due to the high weight of the model, the engine selection would seem to be limited to C6-3's, although a B4-2 MIGHT work. I would suggest that you use at least a 54" launch rod to let the model get up to a reasonable speed before it leaves the launcher. This will help to eliminate problems due to the offset thrust line.

Now all that remains is to convert the Aurora 2001 Moon Bus so that it will hover on the thrust of one engine and move forward using another engine. Meanwhile, it's time for my weekly visit to my friendly local clear plastic dealer

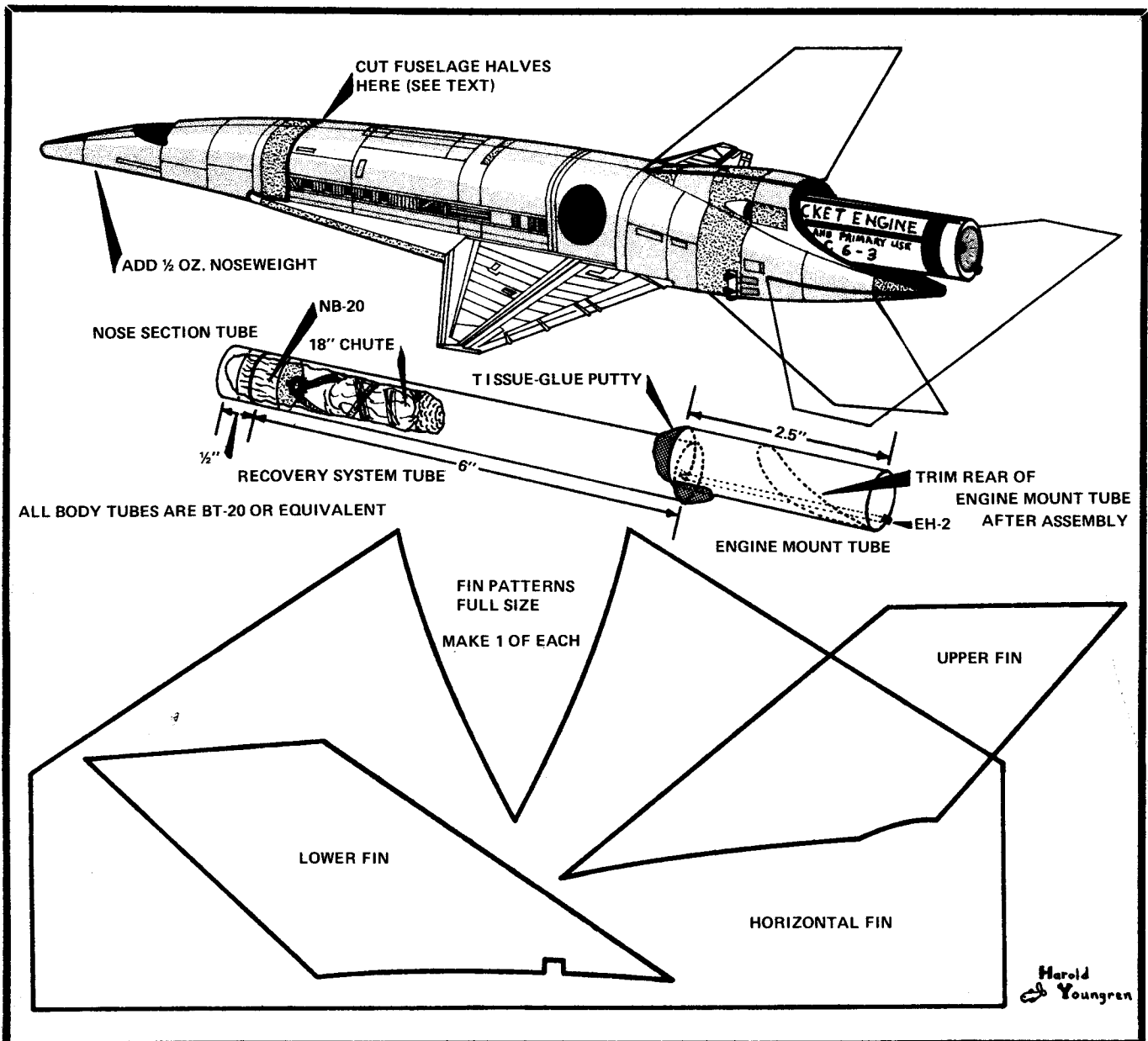

COME FLY WITH US!

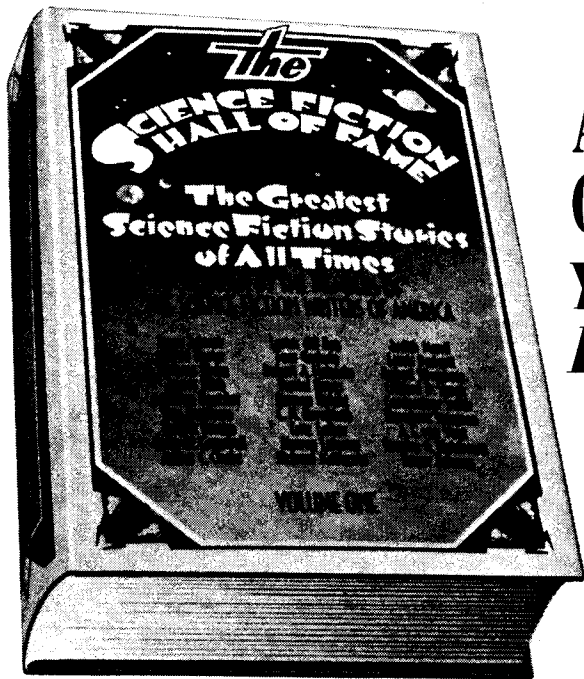

An Epic Voyage
Of The Imagination

YOURS... FOR ONLY 10¢

with membership in the

SCIENCE FICTION BOOK CLUB

THE SCIENCE FICTION HALL OF FAME

contains 26 electrifying stories voted *the best ever published* by the Science Fiction Writers of America. Now this giant anthology, worth \$7.95 in the publisher's edition, can be yours for just 10¢ (to help cover shipping) with membership in the Science Fiction Book Club! Nowhere else can you find such an exciting array of novels, anthologies and great science fiction classics—all at tremendous savings. As a member, you pay only the low Club price of \$1.49 plus shipping and handling for each, despite the much higher prices of the publishers' editions. (Occasional extra-value books are offered at slightly higher prices, but you always have the privilege of taking or refusing any book.) To take advantage of this special, no-obligation offer, simply fill out and mail the coupon at the right. It contains a complete description of how the Club works, and it will be your ticket to a galaxy of thrilling reading pleasure.

SCIENCE FICTION BOOK CLUB P.O. Box 5911, Clinton, Iowa 52732

Please accept my application for membership and rush me THE SCIENCE FICTION HALL OF FAME. Bill me just 10¢ (to help cover shipping). Each month send me the Club's free bulletin, *Things to Come*, which describes coming selections. If I do not wish to receive a monthly selection or prefer an alternate, I simply give instructions on the form provided. For each book I accept, I pay only \$1.49 plus shipping and handling, unless I take an extra-value selection at a higher price. I need take only 4 books within the coming year and may resign at any time thereafter.

NO-RISK GUARANTEE: *If not delighted with my introductory book, I may return it within 10 days, owe nothing, and my membership will be canceled.*

Mr. _____
Mrs. _____
Miss _____
(please print)

Address _____

City _____ State _____ Zip _____

Members accepted in U.S.A. and Canada only.

6

3-646-9-20339

Reader Design Page

This month's Reader Design in the "Arrow-Head" designed by Barron Fackler of Highspire, Pennsylvania. The "Arrow-Head" is a sport model which will attract attention because of its non-standard fin design. Two Estes nose-weights (NCW-1) are added to the nose for stability. The "Arrow-Head" will fly well with A8-3 or B4-4 engines.

Parts List

Nose Cone	BC-85
Body Tube	ST-88
Engine Mount	EM-8
Launch Lug	AL-2
Parachute	CP-12B
Shock Cord	SC-18
Screw Eye	SE-12
Balsa Fin Material	BFM-10

(All Parts Available from Centuri)

Each month **Model Rocketry** will award a \$5.00 prize for the best original rocket design submitted by a reader during the preceding month. To be eligible for this prize, entries should be carefully drawn in black ink on a single sheet of 8½ by 11 paper. Sufficient information should be contained in the drawing so that the rocket can be constructed without any additional information.

Submit entries to:
 Rocket Design
 Model Rocketry
 Box 214
 Boston, Mass., 02123

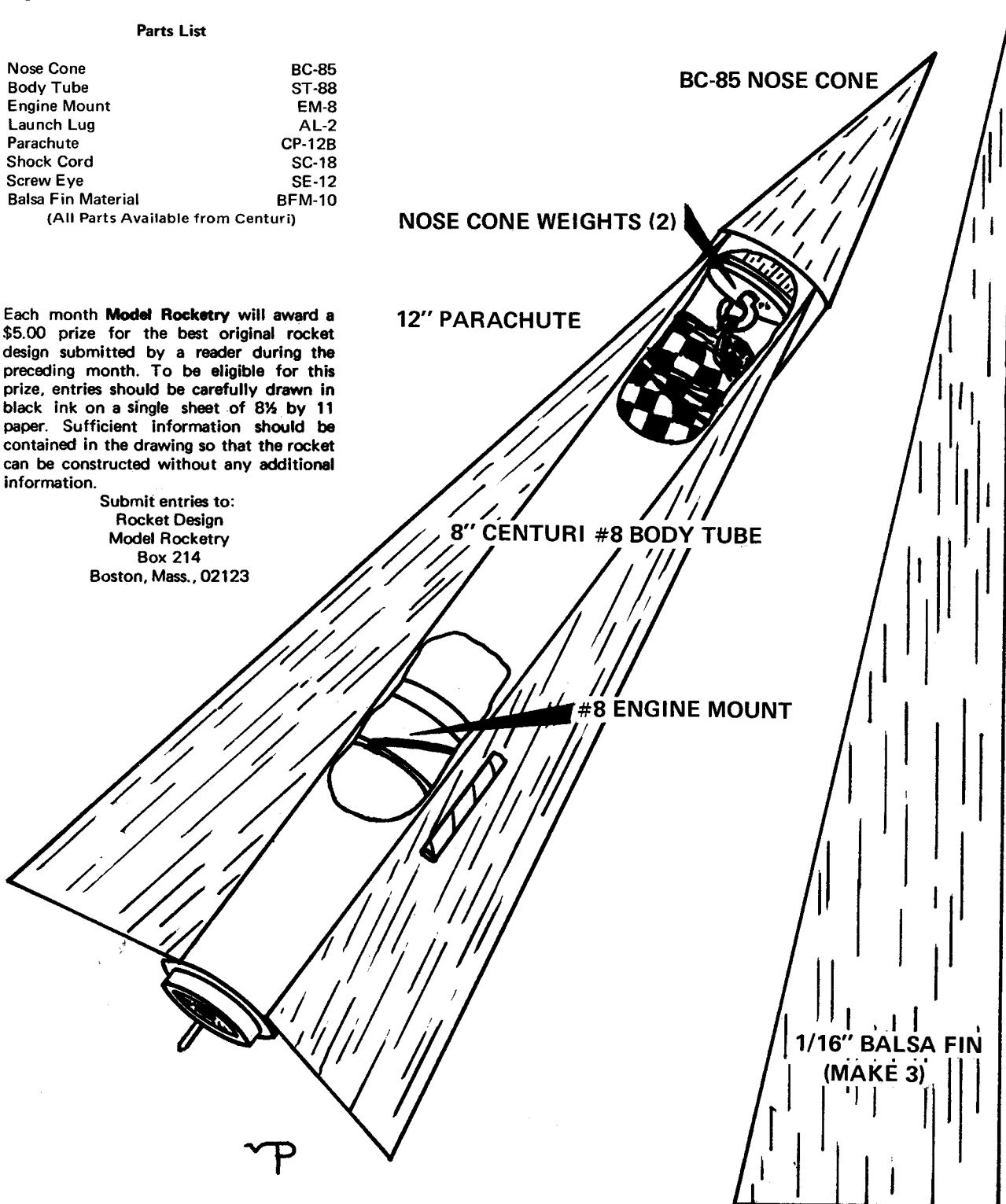

For High-Performance Contest B/G's USE 'CUT-OUT' WING CONSTRUCTION

by Jerry Jones

Built-up wings have long been recognized by model airplane builders as a great weight saving construction technique. Rocketeers have apparently avoided the built-up wing because of a fear that it was too weak to endure the stress of boost. However, the simple cut-away wing construction discussed here actually gives an increased strength over the solid balsa wing. In addition, the Monokote covering material is available in many bright colors which will aid in tracking your B/G. The best part of all is that the covered wing, aside from being stronger, brighter colored, and smoother than a balsa wing, is actually significantly *lighter* than its solid balsa counterpart.

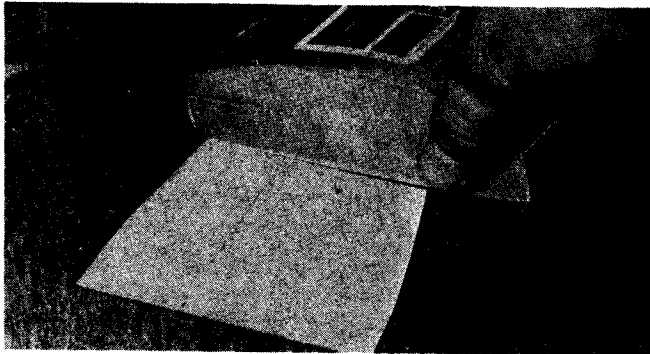

1. Select a sheet of hard balsa stock, cut out the wing panel, and sand the wing to an airfoil shape. The covering method used can follow smooth curves, making possible such efficient wing shapes as this tapered elliptical one. Rough shaping can be done with fine sandpaper, but the final sanding should be done with extra-fine sandpaper. The trailing edge can be made much thinner than normal since the covering material will add strength. About 1/64" is the smallest thickness practical.

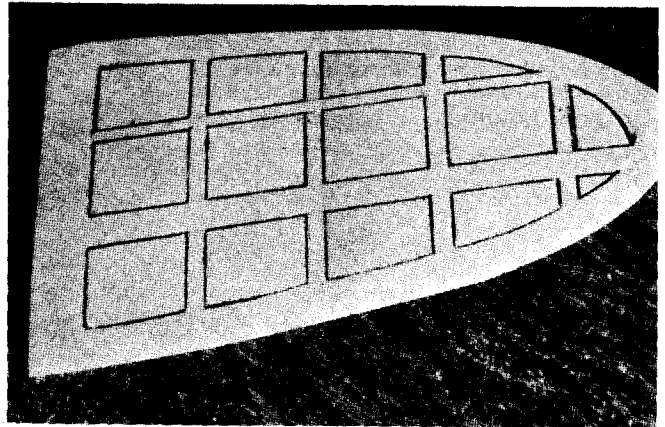

2. Mark the areas to be cut out on the surface of the wing. Be sure to retain a large support around the high-point area, and do not remove "boxes" larger than 1 inch on a side. Approximately 75% of the wing area can be cut away without losing strength in the finished wing.

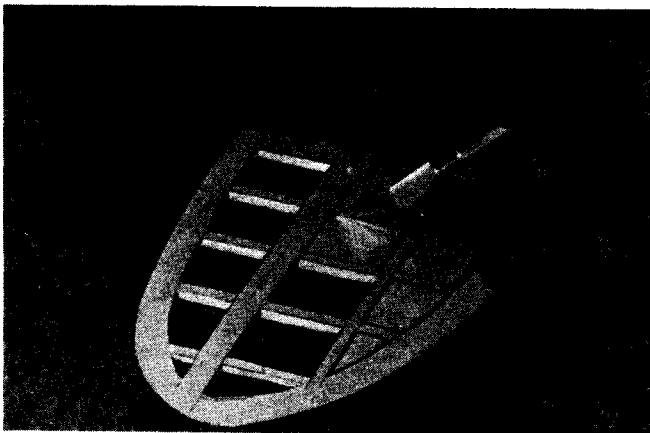

3. Using a sharp X-Acto knife, cut out the marked areas. Be careful not to cut into the supports which will remain, such cutting will weaken the finished wing. The sharper the knife blade, the easier will be the cutting process.

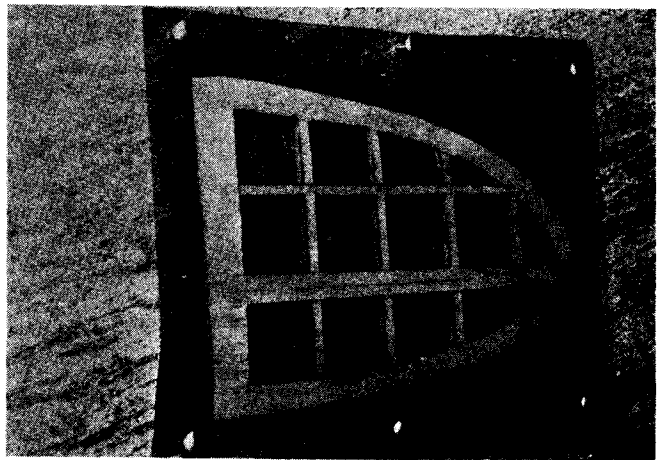

4. Place the wing on a work board, and cut a sheet of Monokote slightly larger than the wing panel. Tack the Monokote to the work board, so that it is stretched tightly over the wing panel.

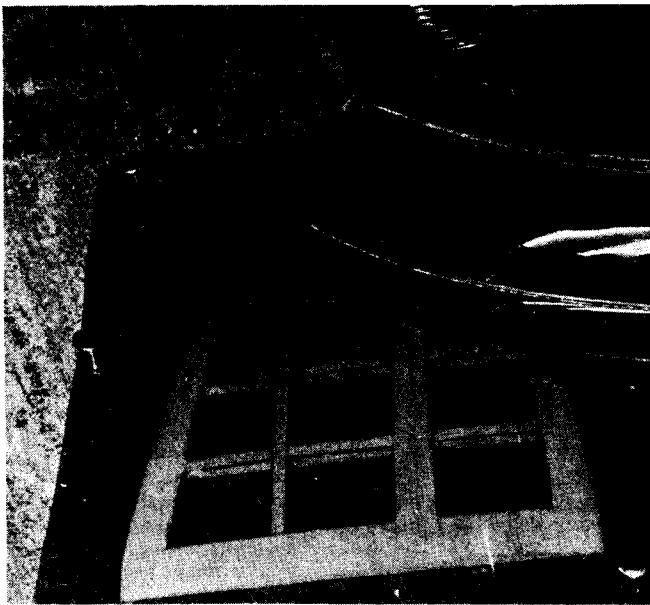

5. Touch the edges with a warm iron (using the heat setting for synthetic fabrics) until they adhere to the wing panel. Do the same to the bottom of the wing. Then heat the surfaces uniformly with the iron to "heat shrink" the wrinkles out of the covering material. If the covering is not stuck to the frame at any point, touch the iron to that area until it adheres.

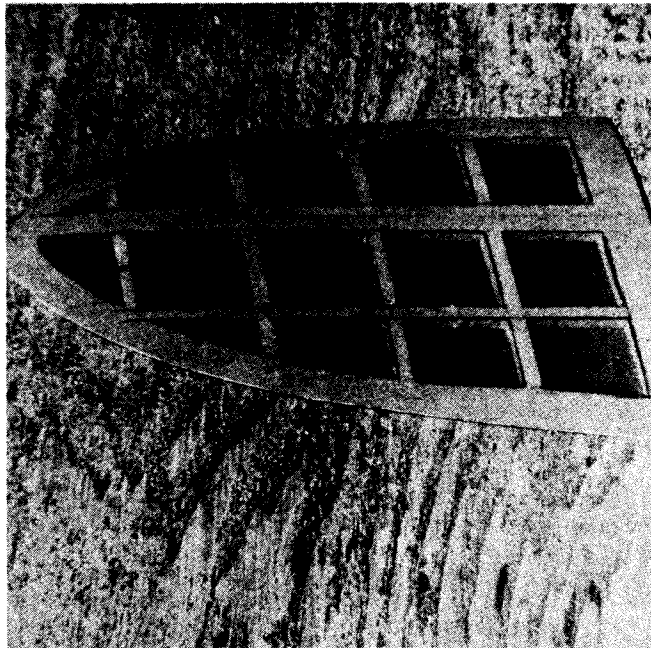

6. The finished wing will be at least as strong as its solid balsa counterpart, but it turns out about 25% lighter. The elliptical wing shown above weighed only 3.4 grams when finished, however the airfoiled solid balsa wing, before cutout and covering, weighed 4.3 grams. The strengths are about equal, though the covered wing is slightly "springier".

If you are planning a competition B/G in the Sparrow or Swift categories, a built-up wing may be the way to go. In the recent International Contest, both U.S. competitors flew built-up wing models. For an even lighter though more difficult to construct wing, a tissue covering can be substituted for Monokote. See the October 1970 issue of MRm for tissue covering details.

Subscribe today! MODEL ROCKETRY

If you're interested in.....
ROCKET TRANSMITTERS
ROCKET ELECTRONICS
SCALE MODEL ROCKETS
TECHNICAL ARTICLES
ODD-BALL DESIGNS
TRACKING SYSTEMS
FINLESS ROCKETS
PAYLOAD ROCKETS
LAUNCH SYSTEMS
CAMERA ROCKETS
BOOST-GLIDERS
RADIO-CONTROL
COMPETITION
CLUB NEWS

Then keep abreast of
the latest developments...



Have MRm delivered to your door!

1 year \$6.00

MAIL TO: Model Rocketry
Box 214 B
Boston, MA 02123

Name _____

Street _____

City _____ State _____ Zip _____

CLUB CORNER



by Bob Mullane NAR 4157

ORGANIZING A CLUB

Whenever two or more rocketeers get together, they almost inevitably wish to form a club. There are many reasons for organizing a club. First, clubs find it easier to obtain a *launch site* than individuals do. They can share equipment, and obtain equipment which individuals may not be able to afford. Recognized clubs can obtain special publications from the manufacturers, they can obtain **MRM** at a discount, clubs with at least 10 members can become a NAR section and obtain special privileges. These and many other reasons make it advantageous to form a club. But the best (and probably the most frequent) reason for forming a club is simple — *it's a lot more fun to fly in a group than alone.*

All clubs share common problems. In upcoming months, in this column, I'll be trying to help your club along in overcoming these problems. I'll be drawing on my own experience with the Pascack Valley Section and with the experiences of other clubs. But this month I'd like to help those of you who are just starting to form a club.

The first step is to plan an organizational meeting. Decide on a date and place, and put up notices about this meeting. If your club is being formed in a school or within other organization (for example a YMCA), your meeting will be held at the school or the organization's building. (Be sure to *determine* and *follow* the proper procedures set down for forming such clubs and arranging for meeting rooms.) If you are starting the club on your own, the meeting will usually be at someone's home. When posting notices, be sure to obtain permission wherever you put them. Keep them small (about 8½ X 11 inches), you will find that you won't be given space to put up a huge poster. The poster should be neat, eye catching, and include the following information: the type of club you are forming, who may join (if membership is restricted), where and when the organizational meeting will be held, and who to contact for more information. If the club is open to anyone, put up posters in your local hobby shops as well as in schools, etc. Most hobby shops will allow you to put up such a poster even if they don't carry model rockets, and if they see a lot of interest in rocketry (especially if you leave a "sign up" sheet with the poster) they may begin to stock rockets. Put up the posters at least two weeks before the meeting. If you leave sign up sheets, remind those who show interest by phone or post card a few days before the meeting.

Now that the meeting is all set and you have a number of people coming, what do you do at the meeting? First of all make sure you have an adult supervisor present (as with all activities), meetings of this kind tend to get out of hand and you'll be happy you have someone to control things. A parent, the local hobby shop owner, or perhaps a school science teacher, can usually be "drafted" as the adult advisor. If the majority of people present aren't familiar with model rocketry, give a brief explanation of it. A number of "props" may be helpful here: slides, movies, actual rockets, catalogs, **MRM**, etc.

Next discuss the type of club you want to form: will membership be limited (to a school, town, YMCA, county, etc)? Do you want to set a limit on membership size? What officers will you need? Do you want to be a NAR section? What are the club's purposes? What dues will be charged? What equipment will the club own? Where can the club get support (\$, meeting site, launch site)? Don't try to come to definite conclusions at this meeting — wait until the next one. The meeting can be topped off with refreshments and an informal discussion (bull session). Decide on the time and site of the next meeting before everyone leaves.

The second meeting will be held about two weeks later (again remind everyone by phone or post card a few days before the meeting). By now, most of the "merely curious" will have lost interest and the group that attends the second meeting will be ready to start seriously writing by-laws (rules governing the organization and operation of the club) and will have had a chance to think about the problems facing the club discussed at the first meeting. You should have a secretary writing down the discussion and resolutions of this meeting. Following are the major divisions of the by-laws of most rocket clubs and some discussion of them.

I. Name. You probably already have a name chosen which usually reflects the nature and location of the club (e.g. "East Side High Rocketeers", "Nome YMCA Experimenters", "East Podunk NAR Section", etc.).

II. Purpose. You'll probably want to keep the purposes as general as possible "To operate a rocket range, use model rocketry for research, hold meets, etc." (rather than: "to hold a meet on the second Sunday of each month with the following events..."). Don't worry if at first your club can't meet all its goals, it takes time for a club to become fully active. On the other hand, don't set goals that are obviously

impossible, "To Land a model rocket on the moon..."

III. Membership. Here's where you put any restrictions that you'll have on membership "East Side High Students", "Members of the Nome YMCA", "NAR members in and around East Podunk", etc. Again, don't be too restrictive ("Rocketeers on Main St. between 13 and 13.5 years old") or not restrictive enough ("All rocketeers in the galaxy" — that kid on Alpha Centuri may have trouble getting to the meetings.) It helps if the territory you cover is small enough so everyone can get to meetings. This size is highly dependent on the age of your membership, and the transportation available.

IV. Dues. Many clubs decide on what dues will be charged each year depending on the club's needs, such as equipment to be purchased, newsletter costs, postage, NAR charter fee, etc. If your dues are high (as most beginning clubs are) try to spread the cost over a period of time to make the burden on each member less (\$1.00 per month, instead of \$12.00 on the 1st of January).

V. Meetings. Set a regular interval for meetings ("once a month", "twice a month", etc.) A minimum time should be set for calling of special meetings, such as "five days notice must be given all members when a meeting is to be held." Meetings can, of course, be called more frequently than set in the by-laws, but should not be held less frequently. During the organizational period, frequent meetings will probably be needed.

VI. Officers. Every club needs a president (although he doesn't have to be called that; he can be "Club Chairman", "Head Zog", etc.). The president runs the club's meetings and other activities. The vice-president takes care of the president's job when the president is inactive. The Secretary keeps a record of the meetings' activities (called the "minutes") and is usually responsible for keeping a listing of all club members and notifying them of meetings. The Treasurer handles the money. In a small club, some of these jobs can be combined ("Secretary-Treasurer", "Vice president-Secretary"). Your by-laws should create four distinct jobs and allow for them to be combined if necessary.

VII. Elections. Here, you set up a time and procedure for the election of officers. If you are a school club, follow the normal time and procedure for elections of your school's clubs' officers. Otherwise, the elections can be held anytime. Usual procedure is to elect the president by one polling, the VP by another, etc. Obviously, the candidate with the most votes wins. Be sure you have set a definite time ("the first meeting of the year") and balloting procedure in your by-laws.

VIII. Committees. Committees are groups of people within your club that are responsible for doing certain jobs and carrying out certain activities. For example: Range Operations Committee — builds and maintains club's equipment and operates the range, Library Committee — obtains reference material and runs a library for club members, Contest Committee — runs the club's meets, Publicity Committee — keeps the general public informed of what your club is doing, Laboratory Committee — in charge of the club's research activities. You may find other committees that your club needs and may

(Continued on page 37)

For Boost/Glider Fun

THE BAT

*Designed by
Bill Schmidt*

The *Bat* is a variation on the "saucer-winged" boost/gliders which have cropped up from time to time over the years. The first popular saucer-wing was the *Invader*, introduced in kit form by Estes Industries, but long since removed from the market. Saucer-wing B/G's have a reputation for not turning in particularly high durations. But what they lack in competition performance they make up for with appearance. In this the *Bat* is no exception — its *not* a competition design. It was built for fun, and has proven itself to be a reliable and good looking *sport flyer*. It's been tested with $\frac{1}{8}$ A6-1, A5-2, and B4-2 engines, and it flies well with all of them. With a light coat of black paint on the wings, you'll find yourself flying the most talked about model at your next sport session . . . unless, of course, someone else manages to prang his Saturn V.

Construction of the *Bat* is relatively simple, but it requires a *lot* of balsa wood. In fact, you'll use a whole 3 foot length of $\frac{1}{16}$ " X 3" sheet balsa just building the wings. In addition you need more $\frac{1}{16}$ " balsa for the rudders, enough $\frac{1}{8}$ " balsa to construct the pylon and landing skid, a BNC-29A nose cone, a $\frac{3}{8}$ " length of BT-20 body tube, and a launch lug. Aside from that, all that's required to get the *Bat* flying is a sharp modeling knife, some glue, a piece of streamer, and of course an engine. Don't let the simplicity fool you though, the *Bat* is not a "throw it together in 20 minutes" type of glider. You'll spend at least five hours building this bird (or should it be called more appropriately a *flying mammal*); but most of that time will be in waiting for the glue to dry. Actual assembly time, discounting two 2 hour drying periods when you can be doing something creative like assembling 36 of those new "instant rocket kits," is only a little over an hour.

when you can be doing something creative like assembling 36 of those new "instant rocket kits," is only a little over an hour.

ASSEMBLY

Begin by laying out a sheet of wax paper on a flat working surface. Cut two 5", two 6", and two 7" long balsa sheets from the 3" X 1/16" X 36" stock. That should just about use up the whole sheet if your measurements are accurate! Apply a light coat of Ambroid, or any other strong wood glue of your choice, along one edge of each 5" and 7" sheet and along both edges of the 6" sheets. Allow the glue to get tacky. After a few minutes, add a second layer of glue to the edges. Assemble the wing panels by edge glueing one 5", one 6", and one 7" sheet together (all flush at one end). Lay a sheet of wax paper over each wing panel, and place a book or other flat, heavy object on top of each wing to keep it in place while drying. Set the whole wing assembly aside to dry for at least two hours.

While the wings are drying, cut the pylon and landing skid from a sheet of 1/8" thick sheet balsa. Be sure to cut the pylon exactly as shown in the plans. It is important that the top and bottom edges of pylon be parallel to each other. If they're not a thrust misalignment will result during boost, and the *Bat* will loop under power.

Fasten a nose cone weight (Estes NCW-1) to the rear of the nose cone. Either use a small screw or a small screw eye through the hole in the center of the weight to fasten it. Glue the BNC-20A nose cone securely into the front end of a 3 1/2" length of BT-20 body tube. The tube is then glued to the top of the pylon. Be sure the axis of the tube is lined up with the pylon, so that the engine thrust center line will be along the axis of the pylon. When dry, fillet the body tube/pylon joint for increased strength. Install a launch lug to the side of the pylon just below the body tube.

No engine block need be used in the engine tube since the nose cone will serve as an engine stop when a standard 18mm X 70mm engine is inserted fully in the tube. Since the *Bat* is a sport model, there is no need to worry about converting it to fly with the new short A engines.

Cut the rudders from a sheet of 1/16" thick sheet balsa. Be sure the grain runs in the direction shown on the plans.

FINAL ASSEMBLY

When the wing panels are dry remove them from under the books, and cut out the wings to the shape shown in the plans. Round the leading edge using #400 sandpaper, and taper the trailing edge slightly. Give the whole wing a light sanding with #400 sandpaper until it has a nice smooth surface. Do not sand the root edges.

Pre-glue the dihedral joint with a coat of ambroid. Locate a box or other suitable dihedral support approximately 2 1/2" high. Apply glue to the dihedral joint. Place one wing panel flat on a sheet of wax paper. Support the center of the other wing panel at approximately 30° (2 1/2" support under the tip of the center section of the wing). Set aside the entire unit to dry.

Round the bottom edge of the landing skid by sanding with extra fine sandpaper. Also round the leading and trailing edges of the rudder, but do not sand the root edges.

When the wings have dried apply a glue fillet to the bottom of the dihedral joint. Glue the rudders in the locations indicated on the wing panels (see plans). Note that the rudder spans all three sections of the wing. This wing/rudder glue joint gives added strength to the three section wing.

The landing skid is glued to the bottom of the wing. Glue the pylon to the forward part of the wing as shown in the plan. Fillet the pylon/wing joint for increased strength.

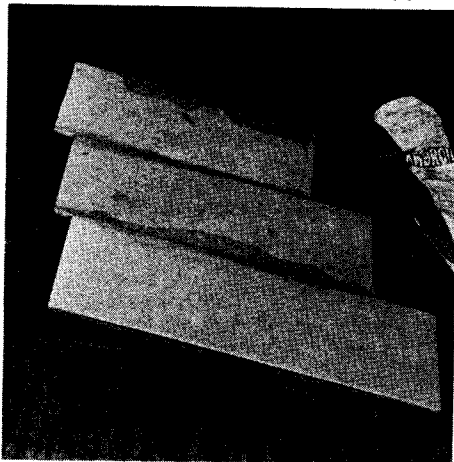

A six inch, seven inch, and eight inch balsa sheet segment are glued together to form the wing. Use wax paper to keep the glued wing from sticking to the work board.

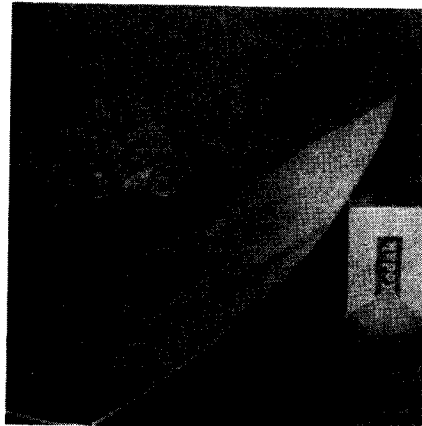

The wing dihedral angle is about 30° from one wing plane to another. One wing is placed flat on the work surface, and the other wing tip is supported approximately 2 1/2" off the surface. A standard 35 mm film box is just the right size to use as a wing support.

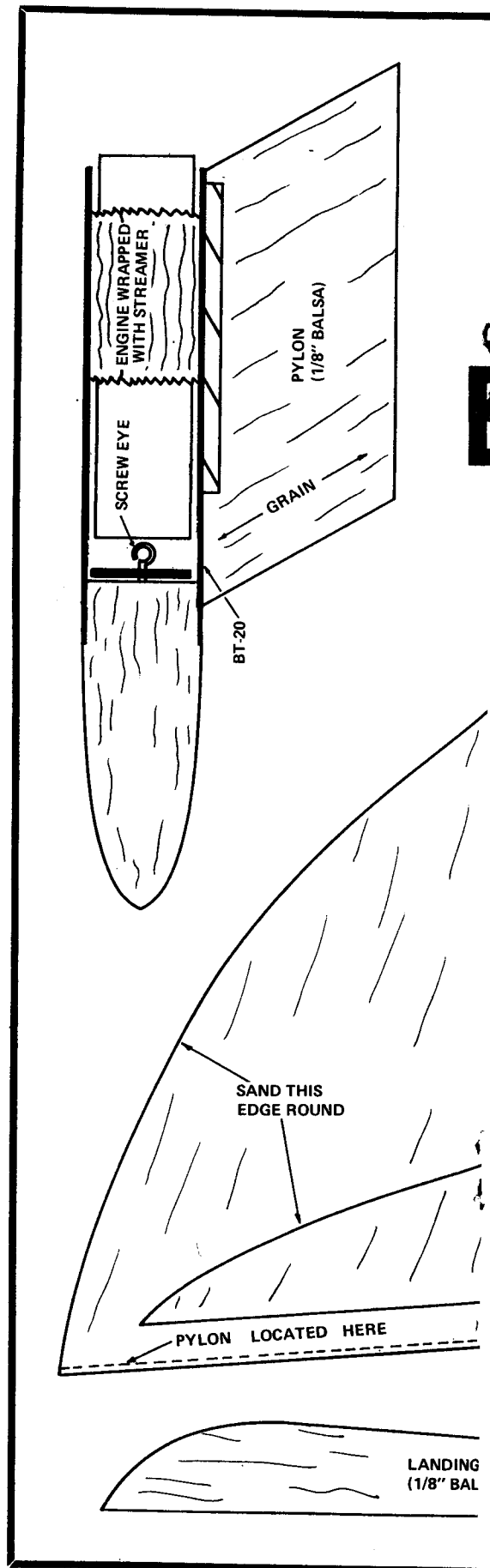

THE BAT

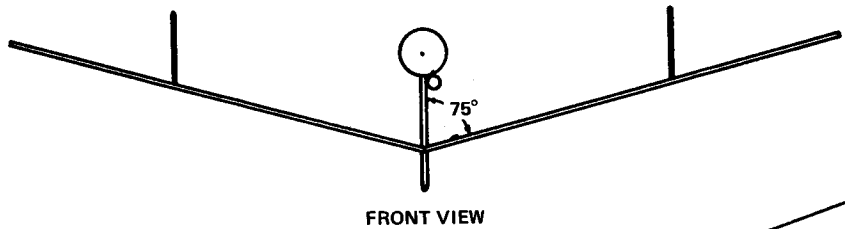

FRONT VIEW

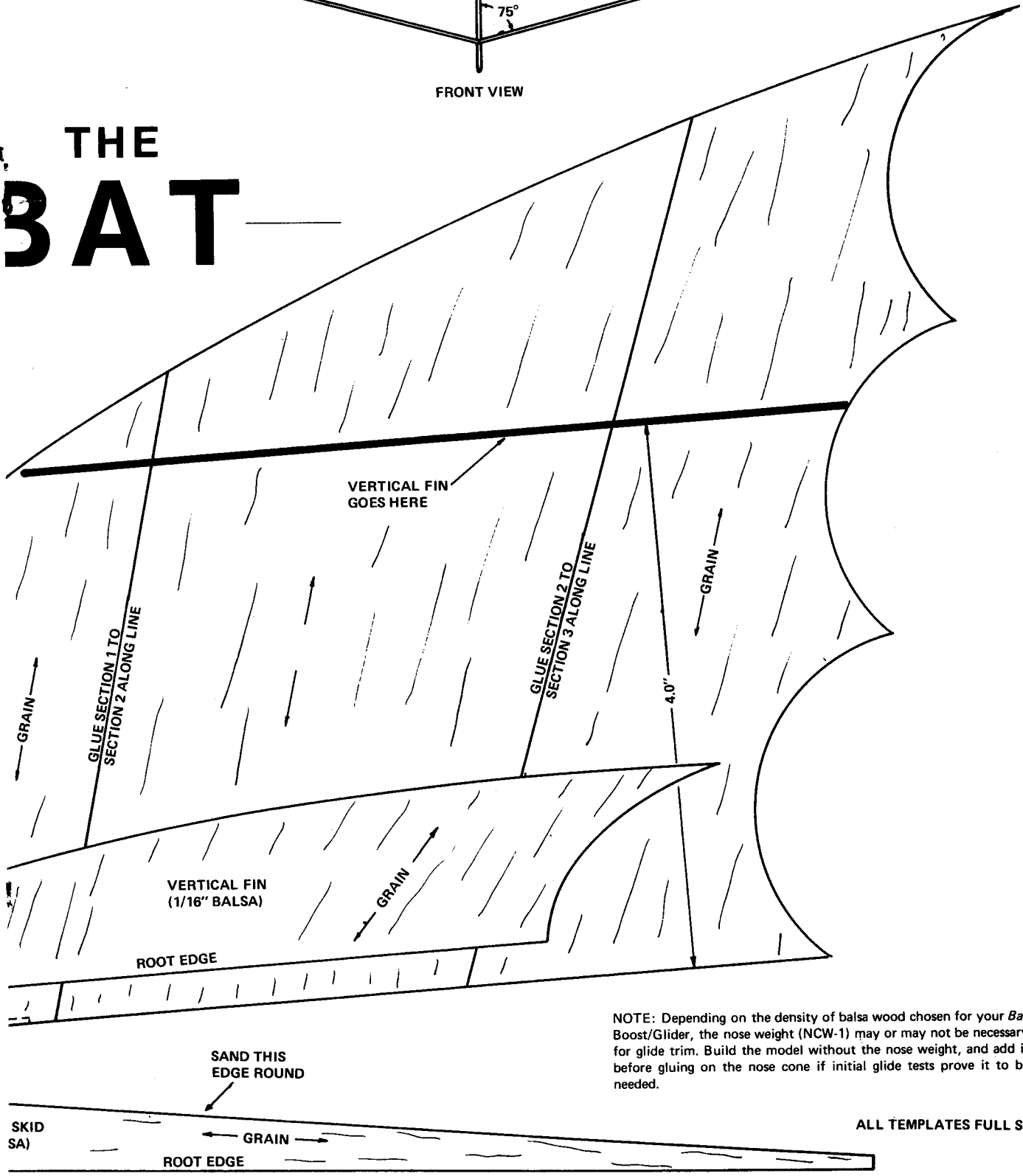

NOTE: Depending on the density of balsa wood chosen for your *Bat* Boost/Glider, the nose weight (NCW-1) may or may not be necessary for glide trim. Build the model without the nose weight, and add it before gluing on the nose cone if initial glide tests prove it to be needed.

ALL TEMPLATES FULL SIZE

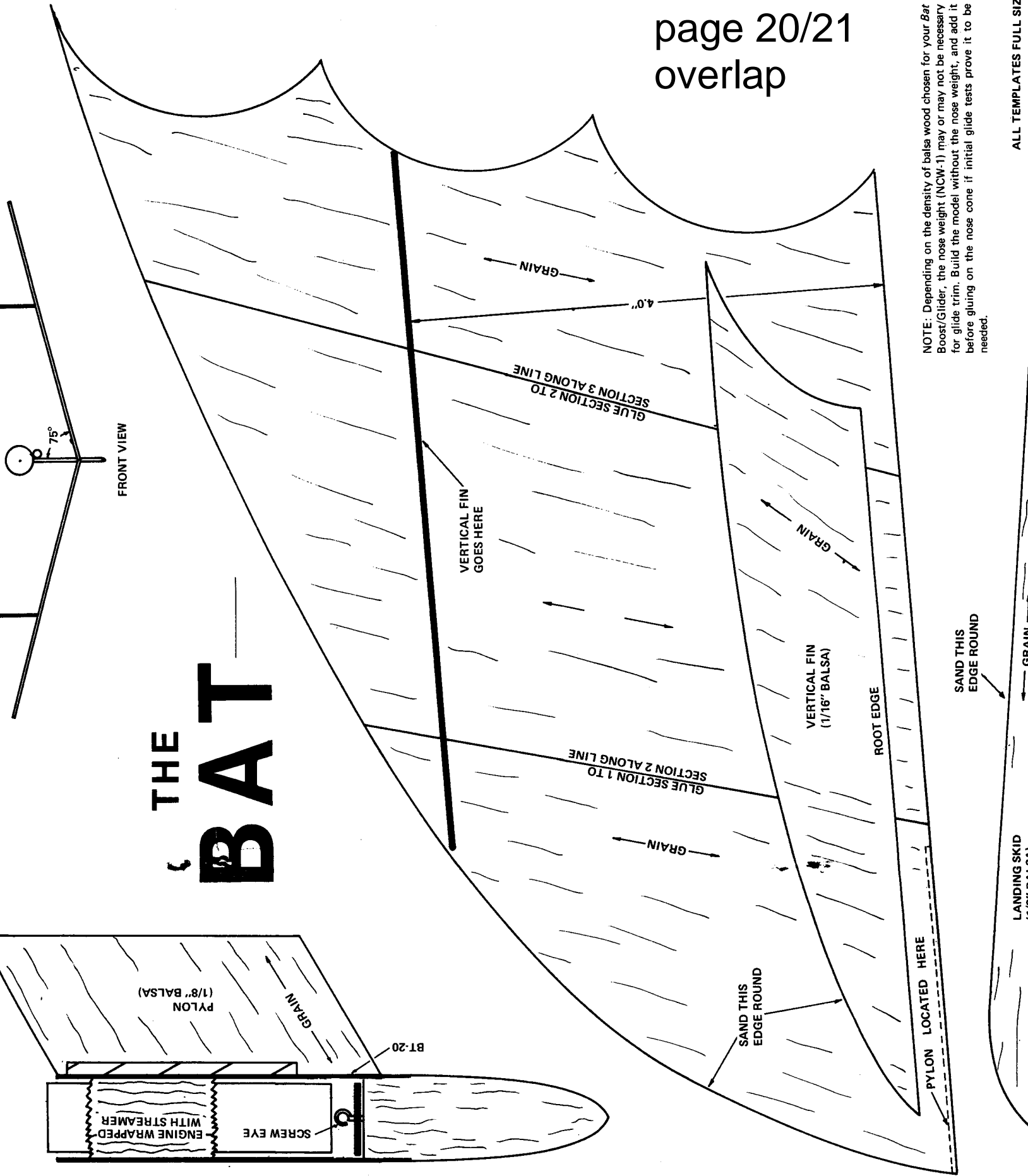

NOTE: Depending on the density of balsa wood chosen for your Bat Boost/Glider, the nose weight (NCW-1) may or may not be necessary for glide trim. Build the model without the nose weight, and add it before gluing on the nose cone if initial glide tests prove it to be needed.

BAT

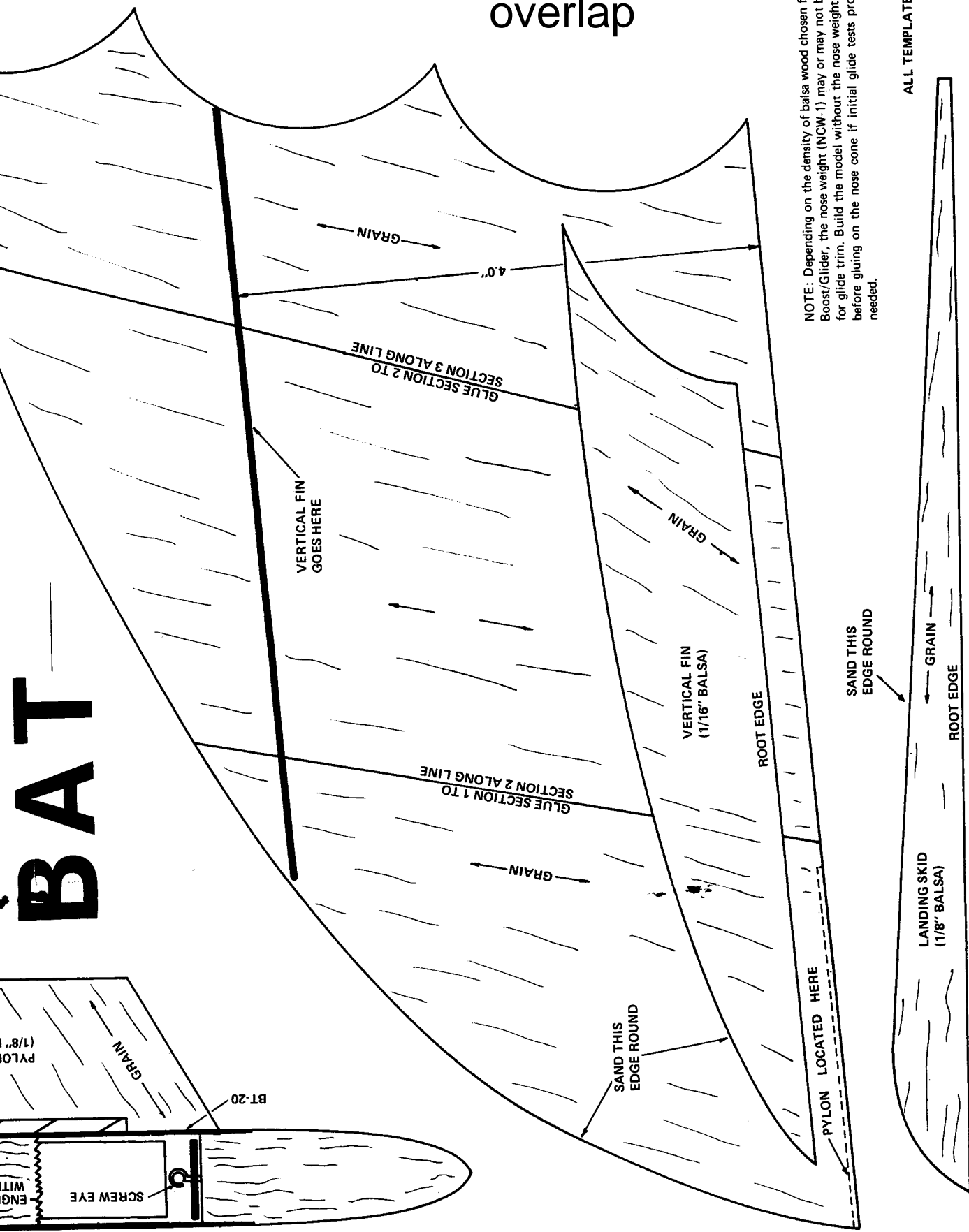

page 20/21
overlap

NOTE: Depending on the density of balsa wood chosen for your Bat Boost/Glider, the nose weight (NCW-1) may or may not be necessary for glide trim. Build the model without the nose weight, and add it before gluing on the nose cone if initial glide tests prove it to be needed.

ALL TEMPLATES FULL SIZE

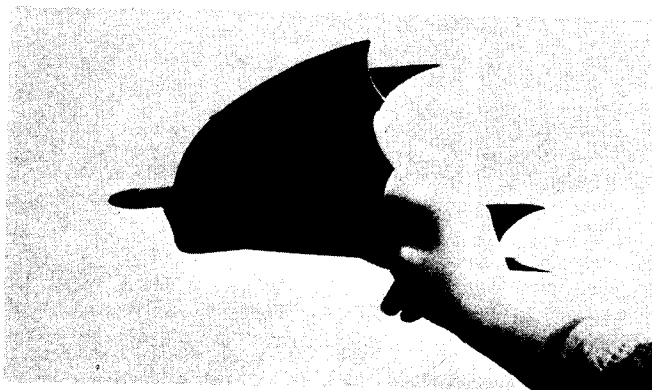

Hand toss the *Bat* by holding the 2nd and index fingers over the trailing edge and the thumb below for support. Move your arm forward and let the B/G slip out.

As with most B/G's the *Bat's* performance will not be enhanced by painting. However, a light sprayed coat of black paint will add much to its appearance, and if you're flying it for sport the slight decrease in duration will not be noticeable.

TRIMMING THE BAT

Trimming the *Bat* is a little different from trimming a normal glider. The first thing you'll notice is that there is no place to hold the *Bat* in order to toss it for a glide. Well . . . there's almost no place to hold it. The best throwing procedure is to hold the 2nd and index fingers parallel to each other on top of the trailing edge of the wing while supporting the bottom of the glider with your thumb (see photo). The glider is tossed by moving your arm forward, and allowing the wing to slip smoothly from between your fingers. It will take some practice, but by the time you get your *Bat* trimmed,

you'll be an expert at tossing it.

Noseweight (trimming clay) is added to the front or rear of the landing skid as needed. If it stalls on a hand toss add some weight to the nose. Continue adding noseweight until it flies cleanly just short of a stall. If it nosedives on your hand toss add tailweight until you just bring it up to a stall.

FLIGHT PREPPING

Select your engine — 1/2A6-1, A5-2, or B4-2. The engine is ejected from the pod at the end of boost, so it is *not* wrapped with tape in the normal manner to assure a tight fit. Instead, a 2 1/2" X 9" piece of 1/2 mil aluminized mylar streamer material (or other *thin* streamer material) is taped to the engine with a strip of cellophane tape. The streamer is wrapped tightly around the engine, and the engine will be pushed out of the tube by the ejection charge.

Insert the igniter, and your *Bat* is ready for launching. If the boost is not straight and the glider loops, this indicates that there is a slight misalignment between the wing and the pod. You can correct for this (aside from breaking off the pod and starting all over again) by adding a small "trim tab" to the rear of the wing and bending it down to correct for an upward loop. If you have been careful with the alignment, this will not be necessary.

You'll be surprised at how much attention the *Bat's* unusual design will attract at your next flying session. Especially if you give it a light coating of black paint, and get it into the air before anyone gets a good chance to look it over!

"BAT" Parts List

1 Nose Cone	BNC-20B
1 2.75" Body Tube	BT-20J
1 Launch Lug	LL-2C
1 Nose Weight	NCW-1
48" 1/16" Balsa Sheet	5 BFS-20L
12" 1/8" Balsa Sheet	BFS-40L

(All parts available from Estes)

6th Annual Pittsburgh Spring Convention

March 19-21, 1971

FEATURES:

Discussion Groups
Two Banquets
Manufacturers' Displays

Launch
Lectures
Films

Approximate Cost: \$28

For More Information, Mail Form

To:
Alan Stolzenberg
Convention Chairman
5002 Somerville St.
Pittsburgh, PA 15201

Name _____ Age _____
Street _____
City _____ State _____ Zip _____

A Model Rocketry First!

SOUND-

CINEROC

by George Flynn

As NARAM-12 came to a close most of the participants had launched enough rockets out in the hot Houston sun so that they just wanted to get away from rocketry, at least for a few days. But at least one group found an unusual project to occupy their attention from the end of the Awards Banquet on Friday afternoon until their departure on Saturday. With no advance planning, they sat down on Friday afternoon and assembled the system to shoot the first sound/movies from a model rocket in flight.

The whole thing got started when Estes Industries awarded their new CINEROC model rocket movie camera to each first place winner at NARAM. Doug McMullen, who had received two CINEROC's for his two first places, got together with Dick Fox, who just happened to have a "Foxmitter" with him, and things began happening. Within minutes there were six or seven rocketeers involved in the project. The bed

and floor of a motel room were quickly covered with the parts for this historical attempt. Alan Stolzenberg sat on one corner of the bed assembling the carrier rocket from the surviving parts of several NARAM rockets. There was a little problem with the payload section, namely there was none available to fit the Foxmitter and the CINEROC. But that was quickly (hastily?) solved by wrapping several tubes together with masking tape. Charles Andres took care of the recovery system, while Doug Plummer, off in one corner of the room, was assembling an MPC carrier vehicle for his Camroc which he hoped to launch a few seconds before the CINEROC in order to shoot an aerial picture of its liftoff.

"Have you read the CINEROC directions yet?," Dick Fox called across the room to

Doug McMullen who was assembling the payload. "No," he replied, but he expressed hope that it would work anyway!

Since Dick had been flying Foxmitters with his Camroc's for several years to assist in the recovery of "lost" payloads, there was basically nothing new with the system. He had also used a microphone attached to the transmitter in order to record the sounds of a model rocket in flight.

By 6:30 P.M., with almost two hours of daylight (actually twilight) remaining, everything was set to go. A call to Vern Estes indicated that he certainly wanted to go out to the range to witness this event, and so he found himself providing transportation for the flight crew out to the launch field.

Out at the launch site, Forrest McDowell and others from the Apollo-NASA Section

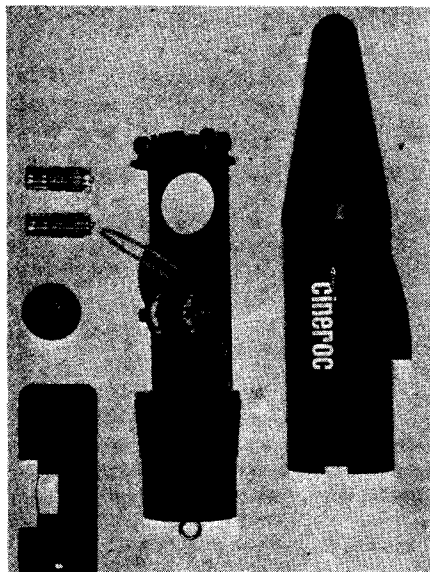

The movie camera used in the first successful model rocket sound-movie experiments was a standard Estes CINEROC as shown above. This modroc movie camera developed by Mike Dorffler of Estes combined with Dick Fox's "Foxmitter" Microphone Module (described on page 24) make sound-movies for modrocs possible.



Just before the first flight the entire launch crew gathered around for a portrait with the sound-CINEROC carrier rocket in the center.



Forrest McDowell (left) and Ben Russell give a final check-out to the doubtful masking tape joint on the payload section.



Dick Fox gives the "OK" on the telemetry from the Microphone module . . .



. . . and Forrest McDowell turns on the CINEROC at T-6 seconds.

Microphone Module for Your 'Foxmitter'

by Richard Fox

A series of Sound CINEROC flights beginning with the one at NARAM-12 led to the development of an improved Microphone Module for use with the Foxmitter-2 Model Rocket Transmitter. The Foxmitter-2 Transmitter itself is described in the June 1970 issue of this magazine. It operates on the 27 megacycle Citizen's Band, and has a range of about one mile when it is in the air. It will accept any of a number of plug-in modules which allow it to telemeter data to the ground. In the case of the Microphone Module, the transmitter sends to the ground the sounds that the microphone picks up. The signal is received on the ground by a walkie-talkie, and can be tape recorded. The improved Microphone Module features a

better sensitivity and better fidelity, but it is larger in size than the unit described a year ago.

Background

The sound tape from the NARAM-12 flight, though useful in determining the cause of the carrier rocket's failure, was unsatisfactory. The noise from the CINEROC motor drowned out the launch crew's countdown, and the fidelity was poor. The fidelity problem was solved by searching the market for an inexpensive microphone of better quality than the one previously used.

The noise problem was a bit trickier, but Dave Crafton worked it out and is presently preparing an article on his payload section. He developed a "CINEROC Simulator", consisting of a small noisy electric motor inserted in the payload section, to avoid "pranging" any CINEROC's. The simulator and the Improved Microphone Module were flown together a number of times, in an effort to minimize the pick up of the vibration of the Simulator's electric motor. The tapes generated by these tests are interesting listening in themselves. All of the noisy

events of the flight, plus the whooshing of the air past the microphone are clearly audible on a number of the flights. On one particular flight, the engine ejected instead of the parachute, and the recording of the descent downward of the streamlined rocket consists of the whooshing of the air as it passes the microphone. The whooshing grows louder and stronger as the rocket falls towards the earth, and terminates very suddenly when the rocket hits the ground.

Incidentally, that was the worst prang with a Foxmitter that I ever witnessed. The vector board, the microphone, a transistor, and two capacitors were destroyed. But some glue, some solder, and \$2.50 worth of electrical parts had the unit flying the next weekend.

One other Foxmitter Microphone prang is worth mentioning. On this particular rocket, which was built by a certain Pittsburgh modeler who shall be referred to as "Ping-Pong", the parachute failed to deploy and the rocket fell to the ground rather quickly. When it hit the asphalt, it bounced up a few feet and hit a second time. The microphone continued to operate during this period of catastrophic impact, and

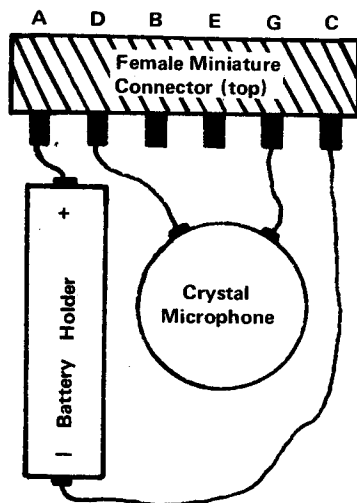

Figure One: MICROPHONE MODULE WIRING DIAGRAM. Use short leads on the microphone to connector joint.

Microphone Module Parts Lists

- | | |
|----------------------------|--|
| Microphone | Lafayette Crystal Microphone Model 99F45098 |
| Female Miniature Connector | R/C Craft Connector, 6 pin Model #19K61; available from Ace R/C, Higginsville, Mo. for \$.50 plus \$.50 handling |
| Battery Holder | Keystone #50053 available from Lafayette as #34E50053 |

A complete kit of parts for the Microphone Module is available from Astro-Communications Co., 3 Coleridge Place, Pittsburgh, Pa. 15201, for \$2.50 postpaid.

were busy disassembling the range. They didn't seem too happy when they were confronted by a group of rocketeers intent on "launching another rocket." But when the project was explained to them they quickly joined in the effort.

It took three people about 30 minutes to prep the rocket in what was fast becoming a race with the sun. Vern Estes gave the CINEROC a final inspection, and pronounced it ready for flight. The "Foxmitter" was turned on, and everyone gathered around the rocket to make noises and test out the transmitter. It worked! Dick could hear voices through his walkie-talkie. Forrest McDowell was a bit more skeptical about the condition of the carrier rocket—a four foot model which was swaying in the breeze from its three foot launch rod. He feared it would fall apart at the payload section joint. But since there was no replacement rocket available, and the sun was setting, the decision was made to start the countdown.

The launch support crew ringed the firing area. Alan Stolzenberg took his position at the firing switch. Forrest McDowell was set to turn on the CINEROC . . . and run. While Dick Fox was recording the signal coming in over the walkie-talkie.

Ten . . . nine . . . I can hear the count over the walkie-talkie, Dick screamed . . . eight . . . seven . . . six . . . Forrest turned on the CINEROC . . . five . . . and Dick "seemed to loose signal" on the Foxmitter . . . four . . . but it was too late to stop the launch . . . three . . . two . . . one . . . only a "vibrating" noise on the walkie-talkie . . . zero . . . the F100 ignited . . . and the rocket climbed . . . 10 feet, . . . 20 feet, . . . 25 feet . . . then it *snapped* . . . it broke apart at the payload joint . . . the Foxmitter fell out . . . *BOINK* . . . it hit the ground . . . while the CINEROC was still cartwheeling in the sky . . . then the CINEROC impacted. Vern ran to the CINEROC, picked it up, and found it undamaged. Dick did the same with the Foxmitter.

It took a few minutes to figure out what happened. The Foxmitter was clearly working after separation. The tape recording revealed those clear *BOINKS* which, from past experience, Dick knew indicated impacts. But why nothing except "vibrations" during boost? The CINEROC, of course! The noise was the CINEROC's electric motor running just inches from the Foxmitter's microphone.

Here is Dick's discription of the tape, after listening to it many times to decipher all the information it contains: "The walkie-talkie failure at T-6 turned out to be the sound generated by the CINEROC motor. The burning of the F100 motor was picked up as a drawn out *BAM* imposed on the vibrating sound of the CINEROC motor. Then a *BOINK* followed by dead silence, indicating that the CINEROC had separated from the payload. A second *BOINK* as the transmitter left the rocket, followed by some hissing as air rushed past the falling microphone, and a *BINK* as the transmitter impacted."

Vern took the film back to Penrose for processing, and it wasn't until MARS-V in October that everyone (almost) got together to see the results of that flight. The film was

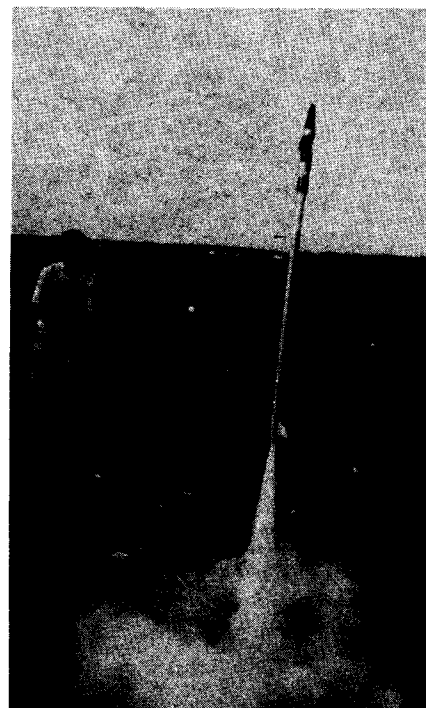

Liftoff! The first Sound/CINEROC, powered by an F100 engine, lifted off perfectly. The launch came at about 7 P.M. on August 21, 1970.

a bit dark, because it was taken too late in the afternoon for good lighting, but it certainly was spectacular! It confirmed the flight pattern that had been deduced from the sound tape. (Since the whole flight took a little over a second, none of the witnesses really could say what happened.) The CINEROC film clearly shows the rocket "flexing" just before it broke apart. Frame by frame viewing even shows a member of the launch crew stepping out of the way of the falling CINEROC.

Since the first flight at NARAM, Dick Fox has flown several more sound CINEROC combinations, and has gotten interesting films back from all of them. Once you have a CINEROC and a Foxmitter, there's really nothing to putting them together and flying the combination.



The CINEROC landed only yards from the launch site. Though it "free-fell" from about 30 feet without a chute, it was still in perfect running order. Vern Estes used the film remaining to photograph the launch crew — Ben Russell (left) and Alan Stolzenberg (right). At the rear of the payload section the masking tape joint which failed can be seen.

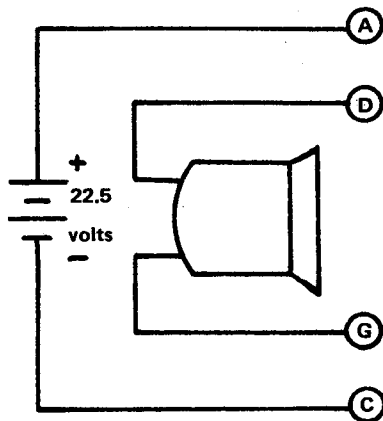

Figure Two: MICROPHONE MODULE SCHEMATIC DIAGRAM. Only a microphone, battery, and connector are necessary for this simple module.

transmitted a rather peculiar PING . . . PING as the rocket hit and bounced.

Construction

The construction of the Microphone Module does not involve any critical steps. The wiring should be done as shown in the wiring diagram, Figure One, and the schematic diagram, Figure Two. Keep the wire from the microphone to the connector as short as possible. A six inch length will work well.

When mounting the microphone on the rocket, the best method is to allow it to hang *outside* of the payload section. If you wish to pick up the vibrations of the flight, you should tape it securely to the side of the rocket; but if you are flying a CINEROC, then place cotton between the microphone and the side of the body tube in order to minimize the pick up of the noise of the movie camera motor.

BOOST/GLIDER STABILITY

by Bob Parks

The subject of model rocket stability has been rather thoroughly discussed. It is the main topic of at least 6 published technical reports distributed by the manufacturers and the NAR. By comparison, Boost/Gliders and Rocket/Gliders have been almost completely ignored. This article is an attempt to explain the basics of what is required to make a B/G stable, and to consider why it does some of the things it does.

STABILITY

There are three main types of stability. What each of these implies can best be shown by means of a simple analogy.

Positive stability is similar to a situation in which a marble is placed inside a spherical bowl. The marble will tend to remain in one spot on the bottom of the bowl. If it is moved to any other part of the bowl, it will return to the original spot on the bottom after it has been released.

Neutral stability is like a marble on a flat, level table. It will stay in one spot until it is moved by some force. It will remain in the new position until it is moved again.

Negative stability can be compared to a marble on top of an inverted spherical bowl. If you're careful, you can get the marble to balance on the top of the bowl, however, the slightest disturbance will cause it to roll off.

Thus a B/G has *positive* stability if it returns to its original attitude after being disturbed by turbulence, *neutral* stability if it remains in the disturbed attitude after the disturbance, and *negative* stability if it continues to move away from its original attitude even after the original disturbance is over.

It will simplify matters tremendously if we separate the *attitude* of our B/G into rotations about 3 axis. A rotation that results in an up or down movement of the nose is called *pitch*. A rotation that causes the nose to move left or right is called *yaw*. Rotation about the *roll* axis will result in a wing tip moving up or down. A motion in pitch that raises the nose will be considered to be positive or increasing, while lowering the nose will be described as negative or decreasing. A motion that causes the nose to go to the left is called left *yaw*. If the left wing tip were to drop, we would say that the model was experiencing left roll.

Since the stability requirements for boost and glide are so different, it would be best if we considered them separately. Since it is the most specialized, we will look at glide stability first.

GLIDE STABILITY

Since we are generally trying to obtain the maximum possible duration from our B/G, we want it to have the minimum possible sink rate. Before we can find out what stability has to do with minimum sink rate, we must first learn a little about airfoils.

AIRFOILS

The most important thing concerning airfoils is the angle at which

the airfoil meets the air. This angle is called the *angle of attack*. To be able to measure this angle, we will need some reference line on the airfoil. This is usually a line drawn from the trailing edge to the leading edge of the airfoil.

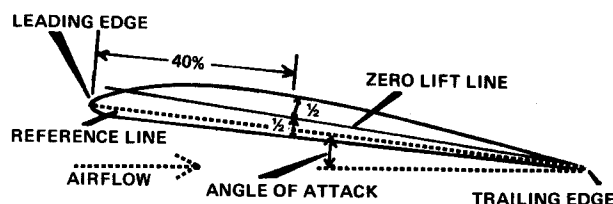

11-70



As we increase the angle of attack (raise the front of the airfoil) the lift increases up to a certain point. Increasing the angle of attack even more will cause the lift to decrease. After we have passed the point of maximum lift, we say the airfoil has *stalled*. There is a certain angle of attack at which the glider will have its minimum possible sink rate. This angle of attack is usually just below the stalling point. For more information, see Doug Malewicki's articles on *B/G Performance* in the December 1969 through February 1970 issues of *MRM*.

Also important to us is the angle at which an airfoil will produce zero lift. This angle can be easily determined to a reasonable degree of accuracy for any airfoil by drawing a line from the trailing edge through a point 40% of the length of the airfoil back from the leading edge and halfway between the upper and lower surfaces of the airfoil. When this line is parallel to the direction of motion, the airfoil is producing zero lift. This line is known as the *zero lift line*.

We are now in a position to determine at what attitude we want our glider to fly. Of course, we want it to fly at the optimum angle of attack, which takes care of the pitch axis. For yaw, we simply want it to point in the direction it's moving. For roll, we want the wing in such a position so that the greatest portion of its lift is working against gravity, namely, horizontal. Since pitch stability is the most critical, let's look at it first.

PITCH STABILITY

If you have ever tried to glide just the wing from a B/G, you know what happens. The wing almost inevitably ends up tumbling (negative stability). Since this is quite obviously unacceptable, we will have to make some modifications. To start out, let's add some sort of a fin (or to use the proper term, a stabilizer) in back of the wing. Since our wing's optimal angle of attack is on the order of a couple of degrees, let's mount the wing to a fuselage at this angle. (The angle between the reference line of the airfoil and the reference line of the fuselage is called *incidence*.) Thus when the top of the fuselage is level, the wing will be operating at its optimal angle of attack. We now glue a stabilizer (for convenience, this term is often shortened to "stab") onto the back of the body at zero angle of attack.

Now, if the wing's angle of attack increases, the stab's will also.

The stab will produce lift, thus rotating the wing back to its original position. A similar effect should straighten things out if the wing's angle of attack should decrease. This, hopefully, will give our glider pitch stability. What Happens? Well, things seem to be a bit more stable, but it's still trying to tumble. So, finally we begin adding noseweight a little at a time, until finally, we get a good glide.

Now, let's take a closer look at what's been happening. The stab is at several degrees negative angle of attack in relation to the wing, in effect, built in "up elevator". There is also a major factor that we have not considered yet, namely the speed at which the glider is flying. This should be very important because for things in the size and speed range of B/G's all aerodynamic forces are proportional to the square of the speed. (For example, if the speed doubles, the forces increase by a factor of *four*, if the speed triples, the forces go up by a factor of *NINE*!) When the angle of attack of wing decreases, the lift decreases, so the glider drops, thus increasing the speed. When the speed increases, the "up elevator" force increases rapidly, thus pulling the nose of the glider up until we are back at our original angle of attack and speed. Similarly, when the angle of attack increases, the glider climbs and loses speed. The up elevator effect decreases and we are back where we started.

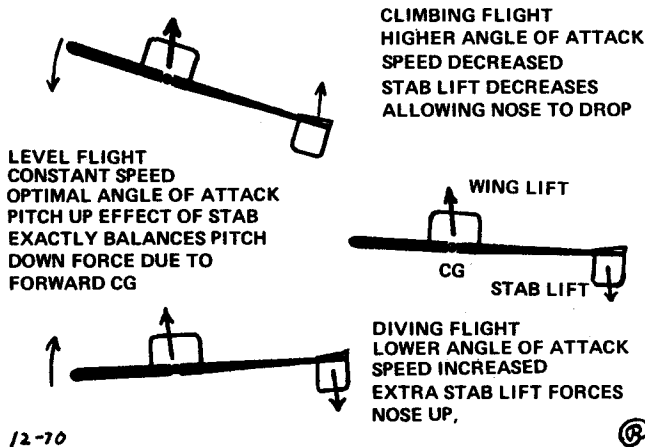

It should be apparent from this that two factors are important for pitch stability. First, the stab must be supplying an "up elevator" effect. This occurs when the zero lift line of the stabilizer is at a lower angle than the zero lift line of the wing. (Note, that it does not matter what the angular relationship between the wing and fuselage or the stab and fuselage is, only the relation between the wing and stab.) Also important is the location of the center of gravity (or center of mass whichever you prefer) in relation to the wing. (This is controlled by the amount of nose weight.)

Thus we have two ways of controlling the angle of attack of the wing during flight. Adding nose weight or decreasing the angular difference between the wing and stab will lower the wing's angle of attack. Removing nose weight or increasing the angular difference will raise the wing's angle of attack. If we carefully decrease the angular difference and remove nose weight we can save some weight while still retaining the optimal angle of attack for the wing. There is one problem, as we do this, we are decreasing the amount of stability of the glider, because the stability is associated with the angular difference between the zero lift line of the wing and the stab. This is all right to a certain extent, but if we go too far, the glider will end up with neutral stability and finally negative stability. The glider will be negatively stable when the zero lift line of the stab is at a higher angle than the zero lift line of the wing.

All of the preceding applies directly to the "conventional" type of glider (namely, one that pretty closely resembles a full size light plane like a Cessna or a Piper in the general layout of components). However, most other types of gliders follow similar rules. On a canard (tail first) glider, the stabilizer must be at a higher angle than the wing since it is in front. Elevons on the back of the wings of the Estes Space Plane and Centuri X-21 supply the "up elevator" effect. On flying wings like the Nitehawk the wing tips serve as a stabilizer. The upturned tips on the SAI Mini-Bat and the trim tab at the back of the CMR Manta also serve to provide stability. A lifting airfoil on the wing and a symmetrical airfoil on the tail of such gliders as the Falcon and Bumble Bee results in the required difference in zero lift

lines. Of course there are always some exceptions to any rule. In this case Rogallo wings and gliding rockets such as the Infinite Loop don't seem to fit properly.

ROLL STABILITY

Now that we have our glider wing producing lift very efficiently because it's flying at the proper angle of attack, we should do something about making sure that the lift is being used to work against gravity. To do this we must keep the wing as close to horizontal as possible, and also right side up.

Roll stability is generally obtained by using dihedral. This means that the wing tips are higher than the center of the wing.

When the glider is disturbed by turbulence, part of the wing's lift will be directed off to one side. This will cause the glider to move sideways. When this sideslip is combined with the forward motion of the glider, we find that the glider is going through the air at an angle, as shown in the drawing.

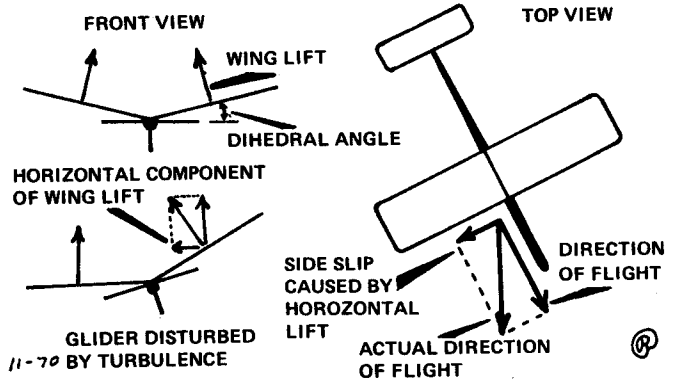

What happens next can be seen if you take a look at the edge of a book or magazine that has been opened to a somewhat exaggerated "dihedral angle". When you are looking at the book from the direction the air approaches it during a sideslip, you should see something resembling the drawing below.

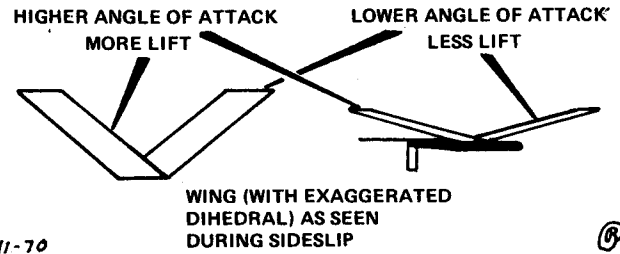

Note that the wing that was the low wing in the beginning is now at a considerably higher angle of attack than the other wing. The extra lift due to this higher angle of attack is used to straighten out the glider.

It may also be useful to note that sweptback and delta wings provide an effect similar to dihedral. This is shown in the next drawing.

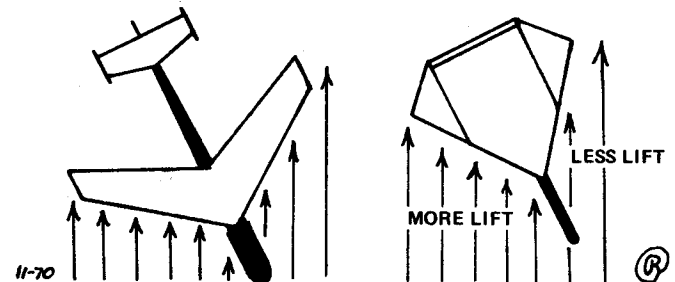

Due to the sideslip, the air is passing over the low wing at an angle closer to perpendicular to the leading edge than on the high

wing. This increases the efficiency of the lower wing so it generates more lift, which straightens the glider. About 10 degrees of sweep-back is equivalent to one degree of dihedral.

YAW STABILITY

Yaw stability is really pretty simple. All you have to do is attach a fin at the back of the glider. It works just like the fins on a normal rocket to keep the glider pointing in the directions it's moving.

Well, we aren't going to get off that easy. The sideslip that we were talking about for roll stability is actually a YAW disturbance. For example, if the glider is forced into a left roll condition, sideslip to the left results. This produces the corrective right yaw we want, but also we get a yaw to the left which is a result of the fin trying to correct what it thought was a right yaw. Conversely, if the glider is disturbed into a left yaw condition, the corrective right yaw and also a left roll result.

There is also another minor problem if the fin area is not equally distributed about the roll axis. Whenever there is a yaw force generated by the fin, it will also result in a roll force. If most of the fin is above the roll axis, the roll force will tend to help the dihedral, a sub-rudder will tend to work against dihedral for the same reasons.

The presence of rudder only radio control will make the situation even more interesting. A sub-rudder (rudder below the fuselage) will tend to roll the glider in the direction we want to turn. A top rudder (rudder above the fuselage) will work against the dihedral and try to prevent the proper amount of bank for the turn.

For a non-controlled glider none of the yaw-roll couplings mentioned above will cause any serious problems. They should however be remembered when designing an R/C glider.

TURNING FLIGHT AND SPIRAL STABILITY

Due to yaw-roll coupling, when the glider turns it rolls slightly towards the inside of the turn. This is good because the glider will turn more efficiently when it is banked. However this could be disastrous if we aren't careful. The best way to explain what happens is to look at the extreme case.

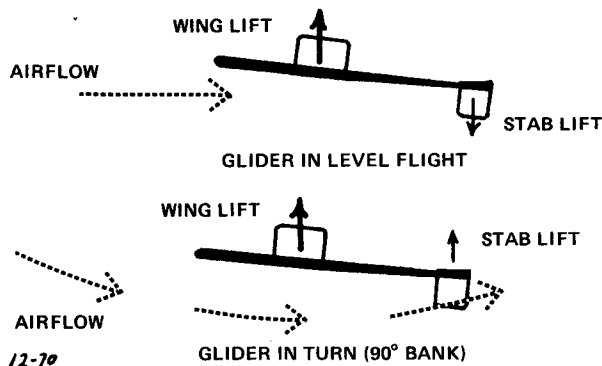

Assume that the glider is in a 90° bank (the wing is vertical and all lift is directed toward the center of the turn. For the moment we are ignoring gravity.) Since the path that the glider is following is curved, the stab is at a higher angle of attack than if the glider was traveling in level flight. This means that the glider's pitch stability is reduced, and that the glider would tend to dive. Of course the glider does not fly 90° banked turns, but the result is still present in even the most gentle turn. Thus, if you trim a glider for straight flight, and then adjust it to turn, you will either have to remove some nose weight or else lower the angle of attack of the stab to get the wing back to the optimum angle of attack.

There is also a danger in having too large a fin. What could happen is that the fin will cause the glider to turn before the dihedral has a chance to correct the original disturbance. Due to the previously mentioned loss of pitch stability in a turn, a diving turn would result. The dive would mean an increase in speed which would give the rudder more force, which would tighten the turn even more etc. A disastrous spiral dive results. The best way to avoid this is to make the rudder as small as possible while retaining

sufficient yaw stability. Increasing the dihedral will also help. Simple rules for estimating how much stab and rudder is "sufficient" will be presented in an article on *Basic Boost/Glider Construction* by Dr. Gerald Gregorek to be featured in an upcoming issue of MRM.

Of course, all of the preceding discussion has assumed that the glider is built *very* accurately. What you may think is a stability problem may just be a warp or misalignment. So before you decide that a certain design is unstable, check to make sure that you did justice to the design by building it properly. That pretty well takes care of glide stability.

BOOST STABILITY

The requirements of boost stability are very simple. We simply want the B/G to point in the direction that it's going, Namely, UP!

Yaw stability is very simple, just like on a normal rocket. It doesn't really matter whether the model rolls on the way up, so roll stability isn't a problem either. Yaw-roll coupling becomes unimportant.

Pitch stability is a little more of a problem. A rear engine B/G is really a normal rocket with oversized fins so there isn't much of a problem here. A front engine B/G isn't quite as nice. First of all, we have the thrust line offset from the C.G. This results in a considerable pitch down (or pitch up in the case of a bottom pod) force.

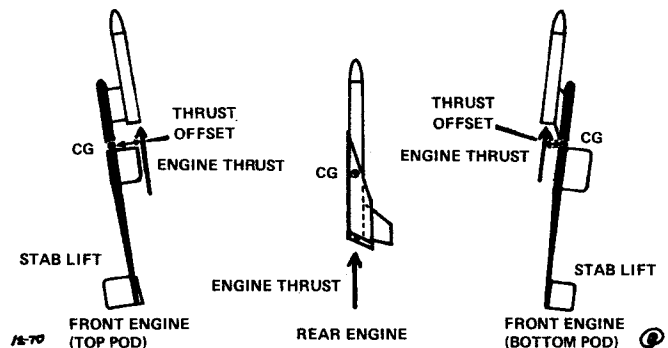

We also have a problem because the force arrangement that we set up for pitch stability also provides velocity stability. The greatly increased speeds during boost tend to produce a very large pitch-up force.

Most of the aerodynamic pitch-up forces can be taken care of by locating the pod pretty far forward to shift the C.G. The remaining pitch up force is generally used to counteract the engine's pitch-down force. This system won't produce a perfectly straight up boost, but it is good enough. A bottom located pod requires some moveable surface to get a sufficient trim change or else it needs some very careful trimming.

One helpful factor that is generally overlooked is that for a given engine-glider combination, the faster it leaves the launcher, the straighter it will boost. There is of course a point at which you will lose more altitude because of friction than you will gain by a straighter flight. However, it appears that the launcher would become larger than anyone would want to transport long before the tradeoff point is reached.

TRANSITION

Transition is a trivial problem when the glider has sufficient stability. A properly trimmed glider will assume its "stable attitude" almost immediately after boost.

STABILITY AND EFFICIENCY

You may have noticed by now that *ALL* of the methods used to gain stability do so at the cost of ultimate efficiency. If just a simple wing could glide it would be fantastically more efficient than any of

the B/Gs we have today. Unfortunately, a simple wing won't glide. That means that we have to add a stabilizer (or equivalent) which generally ends up "lifting downward". We also had to add a fin for yaw control. This means more weight and increased drag. The fuselage added even more weight and drag. With dihedral we end up directing part of our wing's lift horizontally. While all B/G designs must lose some efficiency in order to fly, but to obtain really high performance we need to use the minimum amount of stability practical.

In most cases, I have not supplied any numbers or ideas as to how much of something is required or how much is too much. This was because the best way to find out what is required is to look at

what people are flying, and also look at magazine plans and at the various manufacturers kits. Then, start trying various things until you find a design you like and will work well for you. The main purpose of this article is to explain what is happening to your glider and what you can do to make it work better.

A more detailed discussion (152 pages to be exact) is contained in the book *Circular Airflow and Model Aircraft* by Frank Zaic. Copies of this book are available from Model Aero Publishers, Box 135R, Northridge, CA 91324 for \$3.00 postpaid.

I will try to answer any questions that are accompanied by a self-addressed stamped envelope. Questions should be sent to me care of MRM.

New Product Notes

A new company, Lercari Engineering, has put on the market a sophisticated launching system for the serious rocketeer. It is called The Remote Control Motorized Rocket Launching System.

The system consists of a Motorized Launching Platform and a Monitor/Control Panel, interconnected by a 25 foot communications cable. The Motorized Launching Platform has two battery driven motors, one to change the elevation launch angle (angle from verticle) and the other to change the azimuth launch angle (direction along ground). These motors are controlled from the Monitor/Control Panel. The angles are electronically sensed and displayed on a calibrated launch angle meter on the panel. The system permits the accurate launching of a rocket in almost any direction. A descriptive brochure is available for 20¢ from Lercari Engineering, Box 90894, Los Angeles, Calif. 90009.

Two new designs from Centuri are now available by mail order and at your hobby shop. The "Egg Crate" is a heavy duty payload model designed to loft a raw egg. The egg is cushioned in foam rubber within the 2.04" diameter payload capsule. The kit contains all the parts necessary to build either a two or three engine cluster model. The "Egg Crate" stands 20.3" tall, and weighs 3.25 ounces. It is priced at \$4.50.

The "Mach 10 Rocket Plane" is a unique new boost/glider from Centuri. It boosts straight skyward powered by a B4-2 or C6-3

engine, ejects a "target marker" (attached to a streamer), does a couple of loops, and then settles into a circular glide path earthward. The "Mach 10" comes complete with all parts, illustrated instructions, and colorful decals for only \$2.25.

Spacemaster Enterprises new catalog is out. It lists a complete stock of plastic model kits suitable for conversion. Among the "hard to find" items which Spacemaster has ready for shipping is the Aurora "2001 Space Clipper," which is featured in this month's "Escape Tower". All the space models from MPC, Countdown, Aurora, AMT, Hawk, Monogram, Lindberg, and Revell as well as MPC, SAI and Vashon flying model rockets are listed in the new Spacemaster catalog. Send 25¢ to Spacemaster Enterprises, Dept. MR, Box 424, Willoughby, Ohio 44094 for your copy of the new catalog.

A new addition to their scale line, the Estes "Sandhawk", features a plastic tail section, fins, payload section, nose cone and antennae. This makes the "Sandhawk" an easy-to-assemble, detailed scale model. It stands 30.1" tall, and is designed for D-engine power. The complete kit sells for \$3.25.

Estes Industries has issued their *all new* 1971 catalog. This full color, over 75 page, booklet, lists all the products in the Estes space line. It includes a special "yellow pages" insert of information of interest to



Vern Estes examines the latest scale kit to be released by Estes Industries, the Sandhawk sounding rocket.

rocketeers. Write for your copy to Estes Industries, Dept. 31M, Penrose, Colo. 81240 enclosing 25¢.

Competition Model Rockets has announced the introduction of their long awaited D-Region Tomahawk kit. This kit, an exact scale model of NASA Flight 12.08GT, stands 20" tall and is 0.930" in diameter. The model was precisely scaled from full size manufacturer's drawings. The kit contains detailed instructions, precision plastic scale nose cone, special built-up fins, true to the prototype shroud, pop launch lug, and a special tool for embossing the screw heads onto the fins and payload section. The D-Region Tomahawk is designed to fly with B3-4, C4-4, and D4-4 FSI engines. The kit is available at \$4.50 complete. CMR has also released a new 1971 catalog available for 20¢ from CMR, Box 7022 MR, Alexandria, Va. 22307.

From Rocket Technology Corporation (P.O. Box 3011, Ogden, Utah 84403) comes word of their new high-performance, plastic, scale model of the German A-4 (V-2) missile. The model sells for \$2.75 postpaid.

Rocket Equipment Company has issued a three page listing of available color slides, black & white prints, and color prints of missiles, space boosters, and sounding rockets. Among the newly added items are scale substantiation photos of the IQSY Tomahawk, Mercury Redstone, Apollo/Saturn V, Jupiter C, Vostok, and Black Brant III. The catalog is available for 25¢ from Rocket Equipment Company, Dept. MR, 10 Mulberry Ave., Garden City, New York 11530.

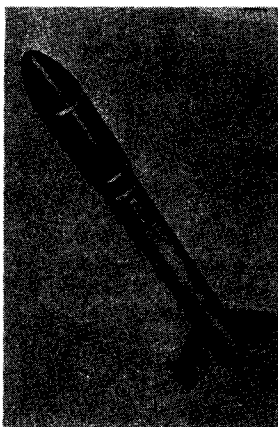

Two new Centuri models, the "Egg Crate" egglofter kit (left), and the "Mach 10" boost/glider (right).

THE MODEL ROCKETEER



NATIONAL ASSOCIATION OF ROCKETRY, Box 178, McLean, Virginia 22101

The Model Rocketeer is published monthly in **Model Rocketry** magazine by the National Association of Rocketry, Box 178, McLean, Virginia 22101. The National Association of Rocketry, a non-profit educational and charitable organization, is the nationally recognized association for model rocketry in the United States. **Model Rocketry** magazine is sent to all NAR members as a part of their membership privileges. NAR officers and trustees may be written in care of NAR Headquarters. All material intended for publication in *The Model Rocketeer* may be sent directly to the editor.

Center of Pressure Calculations

by James Barrowman

Officers of the Association

Elisworth Beetch	President
Bryant Thompson	Vice-President
John Belkewitch	Secretary
William Rich	Treasurer
Robert Atwood	Section Activities
James Barrowman	Publications Comm.
James Kukowski	Public Relations
John Worth	Membership Comm.
G. Harry Stine	Liaison Comm.
Gerald Gregorek	Standards & Testing
Leslie Butterworth	Trustee
A. W. Guill	Trustee
Albert Kirchner	Trustee
William Roe	Honorary Trustee
NAR Contest Board	
Richard Sipes	Technical Services
5012 60th Avenue	Slot and Wing Hobbies
Hyattsville, MD 20781	511 South Century
	Rantoul, Ill. 61866
The Model Rocketeer	
Carl Kratzer, Editor	Leader Admin. Council
320 Thurston Avenue	Jay Apt, Secretary
Ithaca, N.Y. 14850	40 Woodland Road
	Pittsburgh, Pa. 15232
Northeast Div. Mgr.	
Bob Mullane	Southland Div. Mgr.
34 Sixth St.	Richard Sipes
Harrison, N.J. 07029	5012 60th Avenue
	Hyattsville, MD 20781
Mid-America Div. Mgr.	
Manning Butterworth	Pacific Div. Mgr.
Route 1	Lee MacMahon
Eagle Lake, Minn. 56024	13629 Ardis St.
	Bellflower, CA
Mountain Div. Mgr.	
Mei Severe	Southwest Div. Mgr.
8361 Chase Way	Forrest McDowell
Arvada, Colo. 80002	10058 Laston Street
	Houston, Tex. 77055

Our problem faced by all model rocketeers is the accurate determination of the center of pressure of their newly designed or constructed rocket. The basic equations for determining the center of pressure were presented as a Research and Development project at NARAM-8 in 1966 by James and Judith Barrowman. The equations were later published by NASA Educational Services Office for distribution to interested individuals. Mr. Barrowman is an Aerospace Engineer in the Sounding Rocket Branch of Goddard Space Flight Center in Greenbelt, Maryland. This article concentrates on the method and equations used to calculate CP without reproducing the lengthy theoretical derivations. The additional equations needed to calculate CP for elliptical-finned rockets were published in the November, 1970 issue of *The Model Rocketeer*. Further discussion of these CP equations will be presented in future issues of *The Model Rocketeer*.

In order to determine the center of pressure of a rocket, the rocket is divided into regions, and each region is analysed separately. Then the separate results are combined to obtain the value for the entire rocket. The particular set of equations in this paper is for a rocket that can be divided into sections as shown in Figure 1. If there is more than one conical shoulder, conical boattail, and/or set of fins on the rocket, these should be analysed separately and then included in the combination calculations. The equations in this report are valid only if the rocket flies at a small angle of attack. Be sure that the static margin is at least one maximum body diameter to insure small angles of attack.

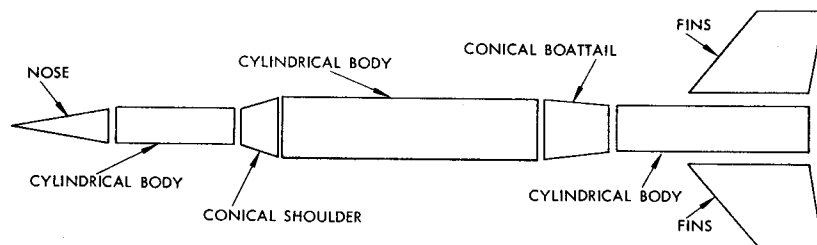

Figure 1

Force

The normal force acting on a rocket is the component of the total force acting on the rocket which is perpendicular to the longitudinal axis of the rocket. In aerodynamic theory, the normal force acting on any part of the rocket is nondimensionalized (in simple terms - corrected for) with respect to the air density, velocity, and a vehicle reference dimension. The symbol for such a nondimensionalized force is C_N . In addition, when correcting for the angle of attack (α), it becomes $C_{N\alpha}$. At low speeds, $C_{N\alpha}$ is a constant and depends only upon the shape of the vehicle. Even though $C_{N\alpha}$ itself isn't normally of interest to the rocketeer, it is very important in the determination of the center of pressure. For simplicity, $C_{N\alpha}$ will be called force in the rest of this paper.

Center of Pressure

In order to be meaningful, the center of pressure locations of all the portions of the rocket must be measured from the same reference point on the rocket. In this discussion, the forward tip of the nose is used as the common measuring point. The distance of the center of pressure from the nose tip is represented by the symbol, \bar{X} .

Subscripts

The subscripts added to $C_{N\alpha}$ or \bar{X} indicate to which part of the rocket the symbol refers. For example, the force on the nose is indicated by $(C_{N\alpha})_N$. If a symbol has no subscript, then it refers to the entire rocket. The subscripts used in this report and their meanings are as follows:

CB	=	Conical Boattail
CS	=	Conical Shoulder
F	-	Fins
N	=	Nose
T(B)	=	Fins in the presence of the body.

Presentation of Equations

A diagram of the forces acting on a rocket and their associated centers of pressure is shown in Figure 2a. The locations of the conical shoulder, conical boattail and fins are defined in Figure 2b.

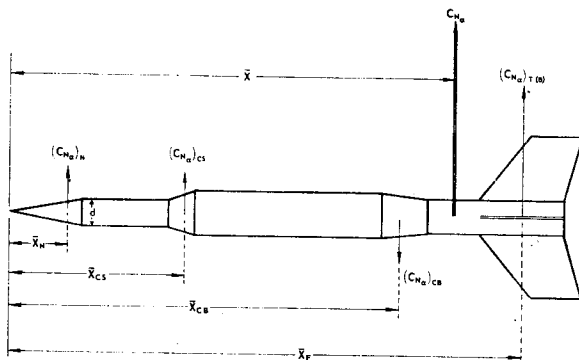

Figure 2a

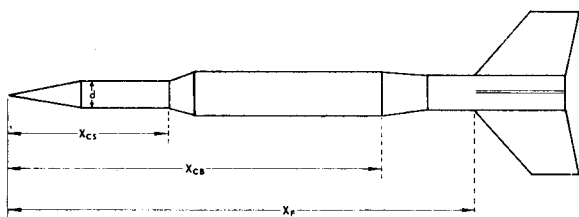

Figure 2b

THE MODEL ROCKETEER

The equations for computing the center of pressure of each section of the rocket are now presented.

Nose

There are two basic nose shapes, cone and ogive. The force on either one of them is the same:

$$(C_{N\alpha})_N = 2$$

The center of pressure location of a cone,

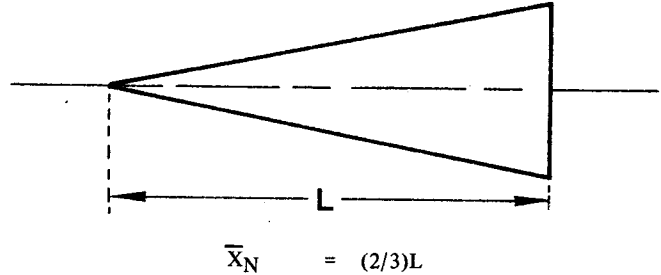

The center of pressure location of an ogive,

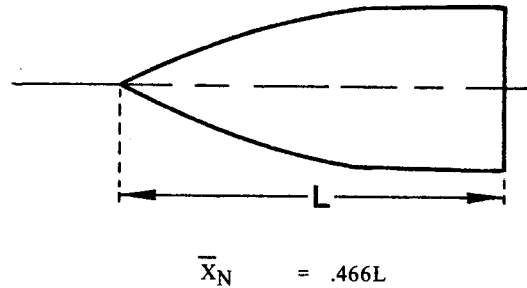

Conical Shoulder

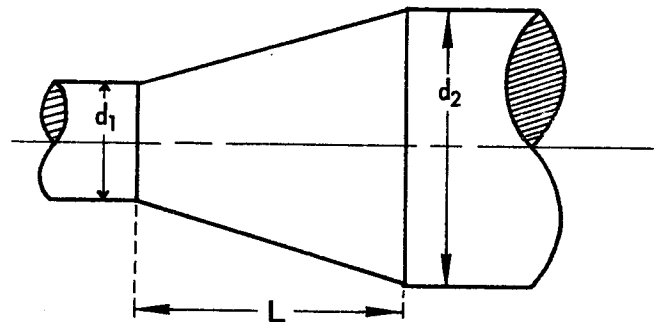

The force on a conical shoulder is,

$$(C_{N\alpha})_{CS} = 2 \left[\left(\frac{d_2}{d} \right)^2 - \left(\frac{d_1}{d} \right)^2 \right]$$

where "d" is the diameter at the base of the nose.

The center of pressure location of a conical shoulder is,

$$\bar{X}_{CS} = X_{CS} + \frac{L}{3} \left[1 + \frac{1 - \frac{d_1}{d_2}}{1 - \left(\frac{d_1}{d_2} \right)^2} \right]$$

THE MODEL ROCKETEER

where X_{CS} is the distance from the tip of the nose to the front of the conical shoulder. (See Figure 2b)

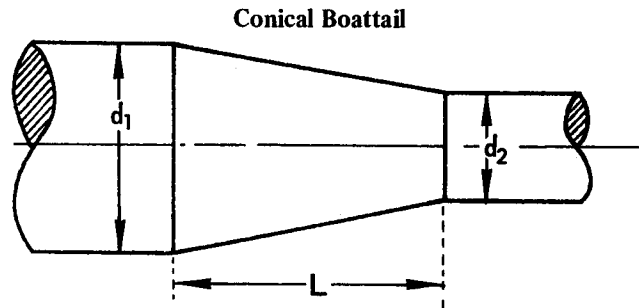

The force on a conical boattail is,

$$(C_{Na})_{CB} = 2 \left[\left(\frac{d_2}{d} \right)^2 - \left(\frac{d_1}{d} \right)^2 \right]$$

where "d" is the diameter at the base of the nose. The force on a conical boattail should be negative.

The center of pressure location of a conical boattail is,

$$\bar{X}_{CB} = X_{CB} + \frac{L}{3} \left[1 + \frac{1 - \frac{d_1}{d_2}}{1 - \left(\frac{d_1}{d_2} \right)^2} \right]$$

where X_{CB} is the distance from the tip of the nose to the front of the conical boattail. (See Figure 2b)

Cylindrical Body

For small angles of attack, the force on any cylindrical body portion is so small it can be neglected.

Fins

Any fin that is not too complicated in shape may be simplified to an idealized shape that has only straight line edges. Such an idealized fin and dimensions associated with it was shown in Figure 3. Obviously, the force on the fins will depend on the number of fins on the rocket.

In terms of the dimensions, the force acting on the fins of an n-finned ($n = 3$ or 4) rocket is:

$$(C_{Na})_F = \frac{4n \left(\frac{s}{d} \right)^2}{1 + \sqrt{1 + \left(\frac{2l}{a+b} \right)^2}}$$

To account for the effect of the fins being attached to the body, the fin force is multiplied by an interference factor,

$$K_{T(B)} = 1 + \frac{r}{s+r}$$

where "r" is the radius of the body between the fins and "s" is

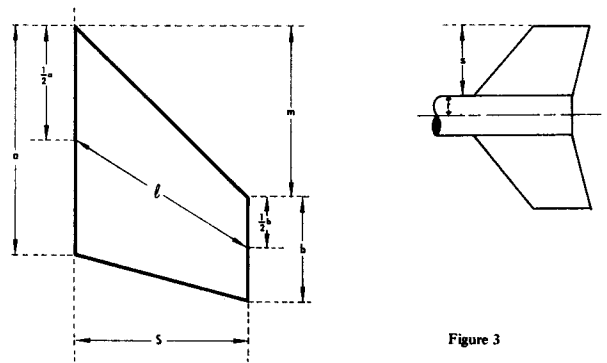

Figure 3

shown in Figure 3. The total force on the tail in the presence of the body is then:

$$(C_{Na})_{T(B)} = K_{T(B)} (C_{Na})_F$$

The center of pressure location of the tail does not depend on the number of fins.

$$\bar{X}_F = X_F + \frac{m(a+2b)}{3(a+b)} + \frac{1}{6} \left(a + b - \frac{ab}{a+b} \right)$$

where X_F is the distance from the nose tip to the front edge of the fin root. (See Figure 2b)

Combination Calculations

The total force on the entire rocket is the sum of all the forces on the separate regions, therefore:

$$C_{Na} = (C_{Na})_N + (C_{Na})_{CS} + (C_{Na})_{CB} + (C_{Na})_{T(B)}$$

The center of pressure of the entire rocket is found by taking a moment balance about the nose tip and solving for the total center of pressure location.

$$\bar{X} = \frac{(C_{Na})_N \bar{X}_N + (C_{Na})_{CS} \bar{X}_{CS} + (C_{Na})_{CB} \bar{X}_{CB} + (C_{Na})_{T(B)} \bar{X}_F}{C_{Na}}$$

Using the Equations

There are two uses for the center of pressure equations. They can be used to either analyse an existing rocket or design a new rocket. To illustrate the analysis of an existing rocket, a sample calculation for a model of the Aerobee 300 follows this discussion. Designing a new rocket is basically a problem of designing the fins. First, determine an initial rocket design which fits such requirements as the desired body tube size, payload compartment, nose cone shape, and any other special features desired. Second, calculate the center of gravity of the design using a standard technique. Third, calculate the center of pressure of the design. Fourth, compare the result with the center of gravity and see if the desired static margin has been obtained. If the desired static margin has not been obtained, then alter the fin configuration and re-analyse the rocket. Check the static margin again. Keep changing the fins until the desired static margin is obtained. The changes that should be made each time will be indicated by the previous result. This is essentially a method of trial and error. The more experience you have doing it, the better and faster you'll become. There are no hard and fast rules for designing anything. You must use your own judgement. The center of pressure equations are just a tool to help you make judgements in design.

SAMPLE PROBLEM
Center of Pressure Calculation
for the Aerobee 300 Model

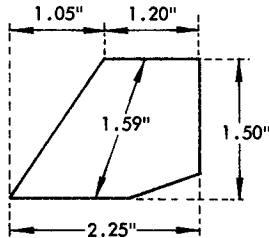
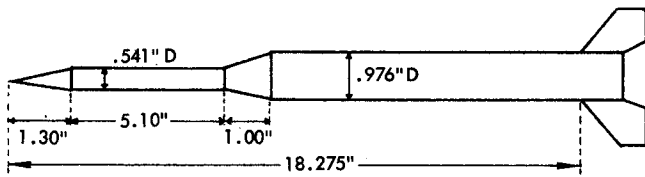

Nose

Shape-Cone

$$(C_{Na})_N = 2$$

$$\bar{X}_N = \frac{2}{3}(1.30) = 2(0.433)$$

$$\bar{X}_N = 0.866 \text{ in.}$$

Conical Shoulder

$$(C_{Na})_{CS} = 2 \left[\left(\frac{.976}{.541} \right)^2 - \left(\frac{.541}{.541} \right)^2 \right]$$

$$= 2 \left[(1.085)^2 - 1 \right] = 2(3.26 - 1)$$

$$(C_{Na})_{CS} = 4.52$$

$$\bar{X}_{CS} = 6.40 + \frac{1}{3} \left[1 + \frac{1 - \frac{.541}{.976}}{1 - \left(\frac{.541}{.976} \right)^2} \right]$$

$$= 6.40 + \frac{1}{3} \left[1 + \frac{1 - .554}{1 - .306} \right]$$

$$= 6.40 + \frac{1}{3} \left[1 + \frac{.446}{.694} \right] = 6.40 + \frac{1}{3} [1 + .643]$$

$$= 6.40 + \frac{1}{3} (1.643)$$

$$= 6.40 + .548$$

$$\bar{X}_{CS} = 6.95 \text{ in.}$$

Fins

THE MODEL ROCKETEER

Three Fins

$$(C_{Na})_F = \frac{13.86 \left(\frac{1.50}{.541} \right)^2}{1 + \sqrt{1 + \left(\frac{2 \times 1.59}{2.25 + 1.2} \right)^2}} = \frac{13.86(2.77)^2}{1 + \sqrt{1 + \left(\frac{3.18}{3.45} \right)^2}}$$

$$= \frac{13.86(7.69)}{1 + \sqrt{1 + (.922)^2}} = \frac{106.5}{1 + \sqrt{1 + .851}}$$

$$= \frac{106.5}{1 + \sqrt{1.851}} = \frac{106.5}{1 + 1.361} = \frac{106.5}{2.361}$$

$$(C_{Na})_F = 45.2$$

$$K_{T(B)} = 1 + \frac{.488}{.488 + 1.5} = 1 + \frac{.488}{1.988} = 1 + .245$$

$$K_{T(B)} = 1.245$$

$$C_{NaT(B)} = 1.245(45.2)$$

$$C_{NaT(B)} = 56.1$$

$$\bar{X}_F = 18.275 + \frac{1.05}{3} \frac{(2.25 + 2.40)}{(2.25 + 1.20)} + \frac{1}{6} \left[2.25 + 1.20 - \frac{2.25(1.20)}{2.25 + 1.20} \right]$$

$$= 18.275 + .350 \left(\frac{4.65}{3.45} \right) + \frac{1}{6} \left[3.45 - \frac{2.70}{3.45} \right]$$

$$= 18.275 + .350(1.348) + \frac{1}{6} (3.45 - .782)$$

$$= 18.275 + .473 + \frac{1}{6} (2.668)$$

$$= 18.748 + .445$$

$$\bar{X}_F = 19.19 \text{ in.}$$

Total Values

$$C_{Na} = 2 + 4.52 + 56.1$$

$$C_{Na} = 62.6$$

$$\bar{X} = \frac{2(.866) + 4.52(6.95) + 56.1(19.19)}{62.6}$$

$$= \frac{1.73 + 31.4 + 1077}{62.6} = \frac{1110}{62.6}$$

$$\bar{X} = 17.7 \text{ in.}$$

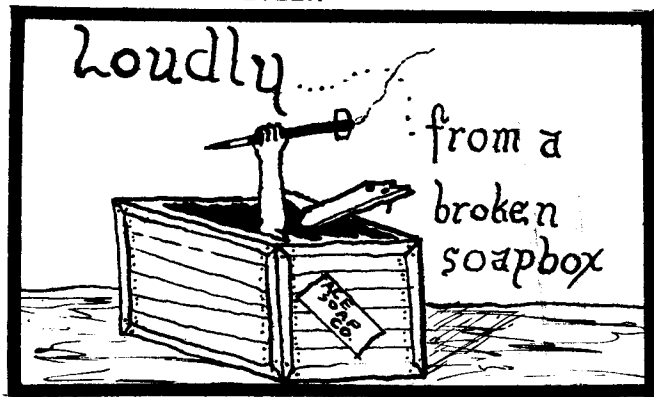

A Point(ed) Question

by Robert J. Mullane

The NAR Contest Board has recognized the fact that a section (or even an individual) can build up an unbeatable number of points during the contest year at local meets where competition is far easier than at NARAM and then enter the NARAM where no one can come close. The board has solved this problem by setting up limits on the total weighting factors allowed in a meet and by eliminating flight points.

OR, HAVE THEY? NARAMS newsletter, ZOG 43, has calculated that a section of 16 members, by flying 12 section meets, can accumulate 15,840 points before going to the NARAM! This year's National Champion Section (Apollo-NASA) fell far short of this figure after the NARAM. In winning the Reserve Championship, Pascack Valley Section nearly doubled its point total at the NARAM and still fell over 4,000 points short of this mark. This is limiting the total possible point total?

A few years ago, much talk was heard about creating a rule to reduce everyone's point total to zero upon entering NARAM. This would put all contestants on an equal level and make the NARAM a true "National Championship Meet". All champs (both section and individual) would have earned their trophy at the NARAM. I'm sure that the champion caliber rocketeers would welcome this opportunity to prove first hand that they are truly champions. All meets during the year could serve merely to qualify the entrant for NARAM. If you don't believe that a pre-NARAM point total can carry someone to a championship, I have first hand proof: it did it for me. At NARAM-10, last minute problems forced me to drop out of all events except R&D. I received a second place in that event for 150 points which was the total I earned at NARAM. I came home with the Leader National Championship that year. Just flight points alone in any event (in order to qualify as having competed at NARAM) would have secured Leader Reserve Championship. It happened to me, it can happen again. I am sure other champs of previous NARAM's can make similar admissions.

But you say the system described above might give unfair advantage to the host section. Two possible methods for solving this problem are available:

1. Limit the number of contestants from each section entering the NARAM.
2. Hold regional eliminations to choose the contestants from each division of the NAR (each division could send a number of contestants proportional to its size, or all divisions could send an equal number.

This contest year has been chosen to provide an open forum on rules changes. The recently issued "White Book" is only for this year, many more changes will be made. Let us take a giant leap for all NAR members by giving them a chance to compete equally.

The opinions expressed above are those of the author and do not reflect NAR policy. Your comments on the above may be sent

directly to Bob Mullane, 34 Sixth Street, Harrison, N.J. 07029. *The Model Rocketeer* welcomes similar articles from anyone who wishes to express his opinion on any phase of model rocketry in an articulate and/or entertaining matter.

NAR Contest Certified Engines

The following model rocket engines currently carry the NAR Contest Certificate (as of November 1, 1970). Please note that certification is being withdrawn on the MPC A3-3 engine. Centuri Mini-Max engines which have been recently redesigned are presently undergoing testing for certification.

Centuri Engineering Company:

1/2A6-0	1/2A6-0S	1/2A6-2	1/2A6-2S	1/2A6-4	1/2A6-4S
A5-2	A5-4	A8-0	A8-3	A8-5	
B4-2	B4-4	B4-6	B6-0	B6-4	B6-6
B14-0	B14-5	B14-6	B14-7		
C6-0	C6-5	C6-7			

L.M. Cox Manufacturing:

A6-0	A6-4	A6-5	
B4-0	B4-3	B4-5	B4-6
C6-0	C6-7		

Enerjet (subsidiary of Centuri):

E24-4	E24-7	E24-10
F52-5	F52-8	F52-12
F67-6	F67-9	F67-14

Estes Industries, Inc.:

1/4A3-1	1/4A3-1S	1/4A3-2	1/4A3-2S	1/4A3-4	1/4A3-4S
1/2A6-0	1/2A6-0S	1/2A6-2	1/2A6-2S	1/2A6-4	1/2A6-4S
A5-2	A5-2S	A5-4	A5-4S		
A8-0	A8-3	A8-5			
B4-2	B4-4	B4-6	B6-0	B6-4	B6-6
B14-0	B14-5	B14-6	B14-7		
C6-0	C6-3	C6-5	C6-7		
D13-0	D13-3	D13-5	D13-7		

Flight Systems Incorporated:

B3-0	B3-4	B3-6			
C4-0	C4-4	C4-6			
D4-0	D4-6	D4-8	D6-0	D6-6	D6-8
E5-0	E5-6				
F7-4	F7-6	F100-0	F100-8		

Model Products Corporation:

A5-3	
B3-3	B6-4
C6-4	C6-0

Vashon Industries:

Cold Propellant Valkyrie I, II

G.M. Gregorek, Chairman
Standards and Testing Committee

Don't allow your insurance to lapse!
Renew your
NAR Membership Now!
NAR, Box 178, McLean, VA. 22101



Happy New Year! It seems that everyone is in hibernation at present judging from the lack of NAR news and correspondence this month. Perhaps some are still recuperating from NARAM. Some members have been complaining of slow service from the Contest Board. Apparently Dick Sipes is gradually becoming aware that CB is not a one-man job. As previous CB chairmen can attest, the time required to issue sanctions, check contest results, make rulings, and coordinate record homologations and Pink Book revisions is overwhelming. Especially when one has a job, a family, and likes to fly rockets. Several members have suggested regionalizing the Contest Board in order to distribute the work load and provide quicker service. Regional Contest Directors could sanction meets and process results for all contests held in their district and report only the final point totals to the National Contest Board for compilation. There is only one thing preventing such a plan from materializing: a lack of qualified, interested members to handle these regional positions. If you are interested in sparing some time and effort to participate in such a plan perhaps a letter to Dick Sipes or HQ will get the ball rolling.

As mentioned briefly last month, a committee will soon be appointed by the Board of Trustees to study the By-Laws and recommend changes to be voted upon by the Trustees and the membership. If you have any suggestions for the committee, feel free to submit them via NAR HQ for consideration. A copy of current by-laws is available from NAR Technical Services for 25¢.

This year NARAM-13 will be held somewhere on the East Coast although the exact site is still uncertain. Due to the large concentration of NAR members in the Northeast this nats is expected to draw the largest attendance ever. Information regarding the location should be available next month.

During the cold winter months when only the most courageous diehards fly models, you can be building up your arsenal for the barrage of competition to follow in the spring. So far this year there has been a record number of meets sanctioned. Sections are reminded to try out some of the newer events for evaluation toward the next Pink Book revision.

Don't forget to send your comments for the "Loudly from a Broken Soapbox" column, the forum for members to sound off about any topic of their choice.

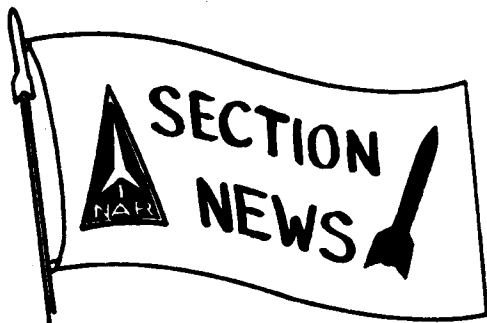

By Charles M. Gordon

YES!!!!!! We are still collecting drawings and/or photos of section flags. As of November 1, 1970 only 11 sections have sent in their's. The flags will soon be appearing each month, a few at a time.

THE MODEL ROCKETEER

Does your section have a flag? Do you want others to see it and to be able to recognize it on the rocket range? If so then be sure to send in a color coded drawing and/or a photograph *now!* If there are any questions or you have your flag ready send to: NAR SECTION FLAGS; c/o Charles M. Gordon, 192 Charolette Drive, Laurel, Maryland 20810.

The Monroe Astronautical Rocket Society Section (Victor, New York) reports that . . . On September 20, 1970, the M.A.R.S. held one of its many "Freek Meets." A Freek Meet is a non-sanctioned meet of easy-going but unusual events. The events of the Sept. 20 meet included Le Mans Start, Ping-Pong Spot Landing, and Three Flight Boost-Glider Duration.

"Le Mans Start is an event in which each contestant must get his ready-prepped rocket on the pad, flown, and recovered all in the *shortest* amount of time. The launching of the entry is controlled by the contestants exit from the launch area. The shortest flight times are usually between 30 and 45 seconds.

"Ping-Pong Spot Landing is an event in which each contestant must land a standard ping pong as close to a mark as possible. This event is lots of fun and is about the only time you might fly a Big Bertha with an A engine.

"Three Flight B/G is a B/G event in which each contestant gets three flights and the best two times are added together to determine winners. This event was inspired by the editorial in the July issue of the *Full Blast*, the section newsletter. We are really trying to eliminate the luck factor of thermals, etc. We have found that adding times of more than one flight together as in AMA glider contests is *not* time consuming. MARS is really quite a B/G section so high times were expected. Flying sparrow B/G the winning times are over two hundred seconds. The winner had 224 seconds averaging 112 per flight - not bad for no thermals. The 2nd and 3rd placers were only 5 seconds apart.

"The Freek Meet events now number eight and will soon be published in the Purple Book."

(Hopefully this "Purple Book" of Freek Meet Events will be made available to all NAR Members.)

As of the end of the 1969-1970 contest year the South Seattle (Washington) Rocket Society reported having 13 senior members out of a total membership of only 37.

Maybe they will let the rust of us in on the secret of attracting senior members.

Announcement is made by Mr. Robert Atwood, Director of Section activities, of the appointment of Tag Powell as manager of section activities for the NAR in the NE division. He succeeds Bob Mullane who turned in his resignation due to studies. Many thanks to Bob and good luck Tag.

Tag's address is: Box 1225, Highland Park, N.J. 08904, Telephone 201-247-6675.

NAR SECTION NEWS appears each month as a regular feature in *THE MODEL ROCKETEER*. Those sections wishing to have news and/or information of their section activities printed in this column should submit such material to:

NAR SECTION NEWS EDITOR
Charles M. Gordon
192 Charolette Drive, Apt. #2
Laurel, Maryland 20810

RADIO-CONTROL
ODD-BALL
MODEL ROCKET ELECTRONICS

COMPETITION
TECHNICAL ARTICLES
BOOST-GLIDERS

Back Issues!!!

TRACKING SYSTEMS
CAMERA ROCKETS
SCALE MODEL ROCKETS
PAYLOAD ROCKETS
FINLESS ROCKETS
LAUNCH SYSTEMS
CLUB NEWS

November 1968 \$.75 □
Model Rocket Recovery by Extensible Flexwing
High Quality Aerial Photography: Part 1
Calculating Drag Coefficients Scale: MT-135
Project Apollo XR-5C: Three-Stage Cluster
The Versitex: A Payload Rocket

February 1969 \$.75 □
Zeta: Single-Stage Sport Rocket The Flight of
Apollo 8 Non-Vertical Trajectory Analysis
The Old Rocketeer: Spotlight on the Manufacturers
Cosmic Avenger: A Model for Class E Engines
Scale Design: Nike-Deacon Model Rocketry for
the Deprived

March 1969 \$.75 □
The Old Rocketeer: Saffek's Saturn High Quality
Aerial Photography: Part III The Biurificon:
Rocket Design Constructing a \$25 Club Launch
Panel How to Finish a Model Rocket Scale
Design: Genie MB-1 The Dynaflo: Single-Stage
Sport and Payload Rocket

April 1969 \$.75 □
Scale: Arcas Report on Apollo 9
Demonstration Launches R. H. Goddard:
Payload Rocket Multistage Altitude Calculations
. . . . Tower Launching Torsion Wire Experiments
. . . . The Skyray Chicago Trade Show

May 1969 \$.75 □
Staged vs. Cluster Model Rocket Performance
The Fra-jyle: Sport Rocket Astroscale Data: The
ASP Rocketsonde Transmitter Construction
Plans The Infinite Loop: Oddball Design
The WRESAT: Australian Satellite Pittsburgh
Convention The Hawk: Sport Rocket
Closed Breech Launching

~~**June 1969** \$.75 □
Ignition Technology Build a Temperature Sensor
for Transmitter Use Body Tube Guide The
MIT Convention The Candelabra: Oddball Design
. . . . The Thumba Rocket Range Scale Design:
L337 Tomahawk~~

July 1969 \$.75 □
Soviet Space Program Scale: Astrobee 1500
ECRM Results F Engine Saturn Misfire
Alley System The Goliath The Why(1)gion
. . . . Spin Rate Sensor and Direction Sensor for Rocket
Transmitter

August 1969 \$.75 □
Radio-Controlled Boost/Gliders A History of
Retro-rockets An Accelerometer for Transmitter
Use Results from WAMARVA-1 The
Dynamite Scale: Rohini RH-75 The Old
Rocketeer: Flat Cat B/G

September 1969 \$.75 □
Color Aerial Photography The Flight of Apollo
11 Astroscale Plans: Black Brant III South
west Model Rocketry Conference Payload
Section for the Transmitter Czechoslovakian
National Championships Plastic Scale Modeling
. . . . Radio Controlled Boost/Gliders: Part II

October 1969 \$.75 □
Conical Model Rockets Astroscale: Nike-Smoke
. . . . Fin Test Vehicle Foxmitter Microphone
NARAM-11 Coverage R/C B/G: Part III
Japanese Activity Dragbrakes Revisited

November 1969 \$.75 □
Scale: Nike-Apache Midwest Regional Report
. . . . Arcturus: Finless Design Ball-Hagedorn Open
Payload Jupiter-C Conversion Washington
State Championship Krushnik Effect

~~**December 1969** \$.75 □
Yugoslav Championships Relay Ignition Systems
. . . . Coefficients The Pumble Bee: Hornet B/G
. . . . Aerial Photo Interpretation Designing with
Computers B/G Performance: Part I
NARAM Regional Report~~

January 1970 \$.75 □
Return to Green Mountain Tilt-A-Tower
B/G Performance MARS-IV Regional Results
. . . . Retro-Rocket Designs Calculating Drag
Coefficients USSR Championships Modrocs
in Vietnam Fly the Micron II Pershing I
Scale Data

February 1970 \$.75 □
Ram-Air Guidance Yugoslavian Parachute Duration
Design Computer Altitude Calculations
Build the Warwick II B/G Performance: Part II
. . . . Body Tube Construction Techniques
Helicopter Recovery Techniques Super-Swift
Tandem B/G's

March 1970 \$.75 □
Converting the Revell LEM to Flight B/G
Performance: Part III Plastic Fin Modifications
. . . . Parallel Fins for Modrocs Ram-Air Guidance:
Part II Fly the Super-Titan D-Engine Flight
Performance Charts

April 1970 \$.75 □
Modroc UFO's HAD Scale Australian Rocket
Trade Show Report Rear Ejection Clip
Psonic Control of Modrocs C_D Determination
. . . . D-Engine Performance: Part II Fly the
NARWHAL For Design Efficiency

May 1970 \$.75 □
Thunder Bird Eagle B/G Plans The First Model
Rockets Vostok USSR Scale Plans Paint
Compatibility The Omega Quadrathon Design
. . . . The Trojan Fint Test Vehicle Optical
Tememetry Lift, Drag, and Pitching Moment
Coefficients for the Nighthawk B/G

June 1970 \$.75 □
The S S Orion Flying Saucer Rocket Plastic
Conversion: The Countdown Saturn V Saffek's
Hiskra B/G Simplified Parachute Duration
Analysis Oberon XBG-111 Styrofoam Wing B/G
. . . . Build the Sport Pittsburgh Convention
Report The Foxmitter II Modroc Transmitter

~~**July 1970** \$.75 □
ECRM-4 Report Korolev RD-107 Vostok
Astroscale Plans The "Triad" Oddball Design
. . . . MIT Convention Coverage Custom Plastic Parts¹
. . . . Czech Competition Coverage Foxmitter
Breathing Rate Sensor Strap-On Wind Tunnel
Plans Experimental Parachute Duration Results
. . . . Plans for the Topsy~~

~~**August 1970** \$.75 □
Flop Wing B/G's Titan III-M with Operational
Strap-Ons Boeing Wind Tunnel Plans
NART-1 Contest Coverage "Bio-1" Payload
Rocket Plans Foxmitter II Temperature Sensor
. . . . Pivot Launch Tower Plans RD-107 Vostok
Scale Data: Part II EFA Pauloader Sport Design~~

~~**September 1970** \$.75 □
Plastic Conversion: Revell "Vostok" Quick and
Easy Balsa Finishing The Dove III Flop Wing
Sparrow B/G Falcon (NIM-4E) Scale Plans
PAR-1 Regional Meet Coverage Accelerometer
Plans for the Foxmitter II "Bio-1" Payload
Rocket: Part II The Flying Bowling Pin~~

Allow at least 6 weeks for delivery.

Model Rocketry Magazine
Box 214
Boston, Mass. 02123

Name.....
Address.....
City.....State.....Zip.....

SUPPLY LIMITED ORDER TODAY!

(Club Corner, Continued)

find that you don't need most of the above committees; this is mainly intended to give you an idea of some duties that committees may be given and of the committees that other clubs have found useful. The committee chairman is usually appointed by the club president and the chairman then chooses the members of the committee.

IX. Amendments. Since conditions change, so must by-laws, but to prevent hasty or foolish changes the amendment procedure should be fairly difficult. (Example: The amendment must be approved by 3/4 of the members present at each of two meetings held at least five days apart with five days written notice be given all members of the meetings and the amendment.)

This has been intended as a general guide to establishing the organization of a club, it is not the only (or the best) way of doing it; it is the way followed by many existing clubs. Your particular situation or experience may call for

other ways. Estes Industries offers a booklet "Guide for Rocket Clubs" which contains more details on the topics discussed here, and includes a sample by-laws. The NAR section charter application also contains a sample by-laws to obtain a copy of it and more help in starting a club, write to NAR headquarters or your Division Manager (see *The Model Rocketeer* section of this issue for the address). In future issues, I'll try to help you along with some common problems: obtaining support (financial and other kinds), legal problems, range equipment, range operations, running meets, publicity, keeping membership interest, and many more. I'd like to hear what your club has done and the problems you've met, perhaps I can share your experiences with the other readers and we can all benefit by them. This column is being drawn from my own experience with Pasack Valley and the experiences of other clubs, so the more clubs I can hear from, the better future columns can be. Write to me c/o MRM and I'll be back next month.



Pittsburgh Spring Convention - March 19-21, 1971. Sixth annual model rocket Convention sponsored by Pittsburgh's Steel City NAR Section. Open to all rocketeers. Featuring: Discussion Groups, Two Banquets, Manufacturers' Displays, Launch, Lectures, and Films. Information from Alan Stolzenberg, Convention Chairman, 5002 Somerville St., Pittsburgh, PA 15201.

MIT Convention - April 3-5, 1971. Convention sponsored by the MIT Model Rocket Society. Open to all rocketeers. Featuring: Computer Demonstration, five Discussion Group Periods, R & D Presentations and Contest, Launch, Banquet, Films. Information from Trip Barber, MIT Model Rocket Society, Box 110, MIT Branch Post Office, Cambridge, MA 02139.

ECRM-5 - April 16-18, 1971. Regional meet sponsored by NARHAMS NAR Section, open to NAR members from Maryland, Virginia, North Carolina, Delaware, West Virginia, and Pennsylvania. Events: Scale, Sparrow B/G, Swift Rocketry/Glider, Class I PD, Class II Streamer Duration, Hawk B/G, and Parachute Spot Landing. Site: Camp A.P. Hill, Va. Contact: J. Barrowman, 6809 97th Place, Seabrook, MD 20801.

Tri-State Competition - June 1971, an open meet for rocketeers in the Amarillo, Texas and neighboring states area. Contact: Amarillo Rocket Modelers Society, 4219 Summit, Amarillo, Texas 79109.

Canadian Convention - July 2-4 1971. Second National Canadian Model Rocket Convention, sponsored by Montreal's ARRA club, and open to all rocketeers. Discussion groups, films, speakers, competition, and a banquet. Full information from: Atmospheric Rocket Research Association, 7248 2nd Avenue, Montreal 329, Quebec, Canada.

Southwestern Model Rocketry Conference - July 20-23, 1971. Third annual convention for rocketeers in the Southwestern U.S. Featuring a flight competition, discussion groups, speakers, films and banquet. Sponsored by the ARC-Polaris Rocket Club, Portales, New Mexico. Write for information to: ARC-Polaris, Drawer 89, Portales, New Mexico 88130.

Mail notices of your contests at least 90 days in advance for listing in Model Rocketry's "Modroc Calendar":

Modroc Calendar
Box 214
Astor Station
Boston, Mass. 02123

STATEMENT OF OWNERSHIP, MANAGEMENT AND CIRCULATION (ACT OF OCTOBER 23, 1962: SECTION 4369, TITLE 39, UNITED STATES CODE) PUBLISHER: FILE TWO COPIES OF THIS FORM WITH YOUR POSTMASTER. POSTMASTER: COMPLETE VERIFICATION ON PAGE 2. FORM APPROVED, BUDGET BUREAU NO. 46-RO29. 1. DATE OF FILING Oct. 1, 1970. 2. TITLE OF PUBLICATION Model Rocketry. 3. FREQUENCY OF ISSUE Monthly. 4. LOCATION OF KNOWN OFFICE OF PUBLICATION (STREET, CITY, COUNTY, STATE, ZIP CODE) 595 Massachusetts Ave., Cambridge, Mass. 02139. 5. LOCATION OF THE HEADQUARTERS OR GENERAL BUSINESS OFFICES OF THE PUBLISHERS (NOT PRINTERS) 595 Massachusetts Ave., Cambridge, Mass. 02139. 6. NAMES AND ADDRESSES OF PUBLISHER, EDITOR, AND MANAGING EDITOR, PUBLISHER (NAME AND ADDRESS) George J. Flynn, 595 Massachusetts Ave., Cambridge, Mass. 02139, EDITOR (NAME AND ADDRESS) George J. Flynn, 595 Massachusetts Ave., Cambridge, Mass. 02139, MANAGING EDITOR (NAME AND ADDRESS) Gordon K. Mandell, 595 Massachusetts Ave., Cambridge, Mass. 02139. 7. OWNER (IF OWNED BY A CORPORATION, ITS NAME AND ADDRESS MUST BE STATED AND ALSO IMMEDIATELY THEREUNDER THE NAMES AND ADDRESSES OF STOCKHOLDERS OWNING OR HOLDING 1 PERCENT OR MORE OF TOTAL AMOUNT OF STOCK. IF NOT OWNED BY A CORPORATION, THE NAMES AND ADDRESSES OF THE INDIVIDUAL OWNERS MUST BE GIVEN. IF OWNED BY A PARTNERSHIP OR OTHER UNINCORPORATED FIRM, ITS NAME AND ADDRESS, AS WELL AS THAT OF EACH INDIVIDUAL MUST BE GIVEN.) NAME Model Rocketry, Incorporated, ADDRESS 595 Massachusetts Ave., (Suite 208), Cambridge, Mass. 02139. George J. Flynn, 15 Roberts Road, Cambridge, Mass. 02138, Gordon K. Mandell, 7 Wyndell Street, Cambridge, Mass. 02138, George J. Caporaso, 2278 West 6th Street, Brooklyn, N.Y., Thomas T. Milkie, 362 Memorial Drive, Cambridge, Mass. 02139, Mr. and Mrs. George Flynn, 10 Mulberry Avenue, Garden City, N.Y. 11530, Mr. and Mrs. Robert Tufano, 2 Mulberry Ave., Garden City, N.Y. 11530, Dr. and Mrs. Robert Tufano, 181 Old Court House Road, New Hyde Park, N.Y., Mr. and Mrs. Eugene Flynn, 21 Elderwood Lane, Huntington, N.Y., Mr. and Mrs. Joseph Flynn, 1249 Greenbriar Lane, North Bellmore, N.Y., Mr. B. Mandell, 32 Truxton Road, Melville, N.Y., Mr. G. Harry Stine, 127 Bickford Lane, New Canaan, Conn. 06820, Mr. Bryant Thompson, 511 South Century, Rantoul, Ill. 61866, Mr. and Mrs. J. Apt, 42 Woodland Road, Pittsburgh, Penn., Robert Mullane, 34 6th Street, Harrison, N.J. 8. KNOWN BONDHOLDERS, MORTGAGEES, AND OTHER SECURITY HOLDERS OWNING OR HOLDING 1 PERCENT OR MORE OF TOTAL AMOUNT OF BONDS, MORTGAGES OR OTHER SECURITIES (IF THERE ARE NONE, SO STATE) NAME None.

ADDRESS None. 9. FOR COMPLETION BY NONPROFIT ORGANIZATIONS AUTHORIZED TO MAIL AT SPECIAL RATES (SECTION 132.122, POSTAL MANUAL) (CHECK ONE) THE PURPOSE, FUNCTION, AND NONPROFIT STATUS OF THIS ORGANIZATION AND THE EXEMPT STATUS FOR FEDERAL INCOME TAX PURPOSES. HAVE NOT CHANGED. DURING PRECEDING 12 MONTHS. HAVE CHANGED DURING PRECEDING 12 MONTHS. (IF CHANGED, PUBLISHER MUST SUBMIT EXPLANATION OF CHANGE WITH THIS STATEMENT.) Not Applicable. 10. EXTENT AND NATURE OF CIRCULATION A. TOTAL NO. COPIES PRINTED (NET PRESS RUN), AVERAGE NO. COPIES EACH ISSUE DURING PRECEDING 12 MONTHS 18,000, ACTUAL NUMBER OF COPIES OF SINGLE ISSUE PUBLISHED NEAREST TO FILING DATE 18,000. B. PAID CIRCULATION 1. SALES THROUGH DEALERS AND CARRIERS, STREET VENDORS AND COUNTER SALES, AVERAGE NO. COPIES EACH ISSUE DURING PRECEDING 12 MONTHS 7,800, ACTUAL NUMBER OF COPIES OF SINGLE ISSUE PUBLISHED NEAREST TO FILING DATE 8,174. 2. MAIL SUBSCRIPTIONS, AVERAGE NO. COPIES EACH ISSUE DURING PRECEDING 12 MONTHS 6,400, ACTUAL NUMBER OF COPIES OF SINGLE ISSUE PUBLISHED NEAREST TO FILING DATE 6,428. C. TOTAL PAID CIRCULATION, AVERAGE NO. COPIES EACH ISSUE DURING PRECEDING 12 MONTHS 14,200, ACTUAL NUMBER OF COPIES OF SINGLE ISSUE PUBLISHED NEAREST TO FILING DATE 14,602. D. FREE DISTRIBUTION (INCLUDING SAMPLES) BY MAIL, CARRIER OR OTHER MEANS, AVERAGE NO. COPIES EACH ISSUE DURING PRECEDING 12 MONTHS 300, ACTUAL NUMBER OF COPIES OF SINGLE ISSUE PUBLISHED NEAREST TO FILING DATE 458. E. TOTAL DISTRIBUTION (SUM OF C AND D), AVERAGE NO. COPIES EACH ISSUE DURING PRECEDING 12 MONTHS 14,500, ACTUAL NUMBER OF COPIES OF SINGLE ISSUE PUBLISHED NEAREST TO FILING DATE 15,060. F. OFFICE USE, LEFT-OVER, UNACCOUNTED, SPOILED AFTER PRINTING, AVERAGE NO. COPIES EACH ISSUE DURING PRECEDING 12 MONTHS 3,500, ACTUAL NUMBER OF COPIES OF SINGLE ISSUE PUBLISHED NEAREST TO FILING DATE 2,940. G. TOTAL (SUM OF E & F - SHOULD EQUAL NET PRESS RUN SHOWN IN A), AVERAGE NO. COPIES EACH ISSUE DURING PRECEDING 12 MONTHS 18,000, ACTUAL NUMBER OF COPIES OF SINGLE ISSUE PUBLISHED NEAREST TO FILING DATE 18,000. I CERTIFY THAT THE STATEMENTS MADE BY ME ABOVE ARE CORRECT AND COMPLETE. (SIGNATURE OF EDITOR, PUBLISHER, BUSINESS MANAGER, OR OWNER).

George J. Flynn

POD FORM 3526 MAY 1968

Club Spotlight:

Pascack Valley Record Trials

by Bob Mullane

New Jersey's Pascack Valley Section sponsored a Record Trials on Sunday September 20th. This was the first opportunity for rocketeers in the Northeast to "take a crack" at the new Rocket Glider categories. Tracking events could not be flown due to a breakdown of range communications.

A "Funny Rocket" event was included "just for fun." About a dozen entries were judged by John Belkewitch and Bob Mullane for unusualness, and care of construction, and ability to fly. The winning entry, by a large margin, was an MPC Lunar-Lectric Launch Pad flight converted by Kevin Flanagan and Brian Skelding. They removed the launch rod, blast deflector, and gantry, and attached a body tube, parachute, and Estes D13-3 engine. It flew straight up to 150 feet.

Gary Bossong did an on the field conversion of his Space Transport Plane from a "funny rocket" (It didn't place in the event.) to a Rocket Glider. At the suggestion of John Belkewitch, Gary added elevons to the wings, removed the chute, and cut a relief port in the body. The glider looped during the B-powered boost, then went into a fast, high sink-rate glide turning in a 10 second flight.

Tony Mendel powered his "flex-wing" Rocket Glider with a B4-2 engine. The strips of body tube which form the leading edge of the wing are folded back into the body during boost. It turned in a 36 second first flight.

The only other notable flight was a possible record setting Eagle flight of 133 seconds turned in by Gary Lindgren. Flying his "Skylark" — an enlarged version of a cross between an SAI Mini-Bat and a Renger Sky Slash — Gary made four successful flights. On the first three, powered by D13-3 engines, he turned in 75, 108, and 80 seconds. The last attempt, powered by a D13-0, was the 133 second flight.



Photos by Bob Mullane

(Left) Gary Bossong's "funny rocket" Rocket/Glider. (Above) Gary Lindgren's "Skylark" Eagle B/G lifts off. (Right) Kevin Flanagan (left) and Brian Skelding prepare their MPC launch pad for flight.

NEW YORK — E. Northport
Complete Line of Model Rockets
LARRY'S HOBBY SHOP, INC.
3018 Jericho Tpke.
Mon.-Fri. 12-9 PM Sat. 10 AM-9 PM

NEW YORK — N.Y. City
"World's Leading Hobby Shop"
Complete Department Store
of all hobbies
(especially rocketry)
POLK'S HOBBY DEPT. STORE
314 5th Ave.
New York City (212) 279-9034

NEW YORK — Uniondale
Biggest and the Best with the Most
Estes & Centuri
CARD & CRAFT
1004 Front St.
Mon., Thurs., & Sat. 9-6 Fri. 9-9, Sun. 10-3

NORTH CAROLINA — Chapel Hill
BILLY ARTHUR, INC.
North Carolina's Leading
Rocket and Hobby Center
Eastgate Shopping Center
9 to 9 Monday thru Friday 9 to 6 Sat.

OHIO — Cleveland
NATIONAL HOBBY, INC.
5238 Ridge Rd.
749-4750
Daily to 6 PM Mon. & Fri. to 9 PM

OHIO — Mansfield
BOB & PETE'S HOBBY SHOP
707 Park Ave. East
Estes-Centuri-Flight Systems-MPC
Where the Champions Buy
Mon. to Fri. 3 to 9 Sat. 9 to 9

OHIO — Upper Sandusky
Complete Rocketry Supplies
THE ROCKET SHOP
640 Skyline Drive
6 to 9 PM 294-1322

PENNSYLVANIA — Monroeville
LORESKI'S HOBBY SHOP
"Miracle Mile" Shopping Center
10 AM - 9 PM (412) 372-5155

PENNSYLVANIA — Scranton
THE DEN, INC.
Everything in Rocket, Planes, Crafts
Route 6, Scranton-Carbondale Hygh
10 AM to 10 PM 7 Days a Week

PENNSYLVANIA — Sunbury
SCHRADER BROS.
470-472 North 4th St.
8 AM to 10 PM (717) 286-6841

UTAH — Ogden
Rocket Motors Our Specialty
Mail Orders Welcome
ROCKET TECHNOLOGY CORP.
432 25th Street
Ogden, Utah 84401

VERMONT — St. Albans
THE HOBBY SHOP
Swanton Road
10 AM to 8 PM 7 Days a Week

VIRGINIA — Culpeper
THE FAMILY HOBBY SHOP
109 S. East St.
10 to 6, Mon. to Sat. Till 9 PM Fri.

WASHINGTON — Seattle
Rocketry for the Northwest
Nationally Known Brands
CAMPUS HOBBY CENTER
4738 University Way N.E.
Open Thurs. Eves. Phone: LA 5-2222

CANADA — Toronto, Ontario
Canada's only exclusive rocket shop
Home of the Canadian Rocket
Society — Complete facilities and
hobby consultants
THE SCIENCE SHOP
137 Yonge St. Arcade

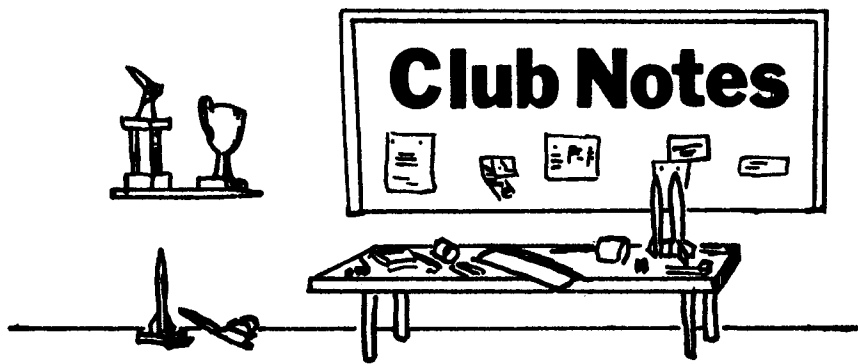

The Third Annual Southwestern Model Rocketry Conference, hosted by the ARC-Polaris model rocket club, will be held in mid-July in Portales, New Mexico. The Conference has been extended from 3 days to 4 days to allow time for more speakers and discussion groups than in previous years. Tentatively scheduled for July 20-23, 1971, the Conference will be held at Eastern New Mexico University in Portales. A flight competition is scheduled from the ARC-Polaris launch field, while the discussion sessions will be held on the ENMU campus. Registration information is available from Southwestern Conference, ARC-Polaris, Drawer 89, Portales, New Mexico 88130.

A model rocket club is being organized in Brockton, Massachusetts. At present the club, with 40 to 60 members, launches from a soccer field. Rocketeers interested in joining the club are invited to contact Wesley Tarlson, 433 W. Elm St., Brockton, Mass. 02401.

Results of the South Seattle Rocket Society section meet - SEAMEE IV - held on October 18th, 1970 are reported in the latest issue of the *Modroc Flyer*. In the Plastic Model event there were three successful entries, a YF-12A by Don Beadle, a Jupiter C by Alan Dayton, and a Vostok by Lewis Walton. In the Scale contest V-2's by Jim Jakeman and Jess Medina took first in B and D Divisions respectively while Alan Dayton captured first in C Division with a Little Joe II.

Two B/G events were on the schedule - Hawk and Sparrow. Only eight entries were flown in Hawk on the windy afternoon, with Lewis Walton's 131 second flight topping the field. Jim Pommert's 124 second flight captured first in Sparrow B/G. There were only three "closed tracks" in the Design Efficiency event, one in each age Division. Don Beadle did the best with a DE of 87.5 m/nt-sec. In Class O Chute Duration Jim Pommert topped the field with 54.75 seconds. Overall, Alan Dayton captured a total of 123 points, while Lewis Walton was second with 96 points.

Rocketeers in Pueblo, Colorado, interested in forming a model rocket club should contact Glenn McCloskey at 1524 Saratoga,

Pueblo, Colorado 81001 or phone 546-0583.

The North Shore Section, the oldest NAR Section in New York, is starting a membership campaign. All interested rocketeers in Nassau County, New York should write North Shore Section, P.O. Box 116, Albertson, N.Y. 11507. The Section is also considering the idea of establishing divisions. Any rocket club in Brooklyn, Queens, or Suffolk counties that is interested in becoming a division of the North Shore Section should also write to the club.

Rocketeers in the Upper St. Clair, Pennsylvania, interested in forming an NAR Section are asked to contact Jeff Austen, 3313 Creall Circle, Upper St. Clair, Pennsylvania 15241.

A model rocket club has been organized at the Pascack Valley YMCA in Park Ridge, New Jersey. Under the direction of G.L. Hannum the club launches regularly from a local school field. Meetings are held every second Saturday in the Fellowship Hall of Pascack Reformed Church.

The Space Research and Flight Control Center of Tampa, Florida, has held two launches at Al Lopez field in Tampa. The club is still looking for new members. Interested rocketeers should contact club president Charles Guterrez, c/o Space Research and Flight Control Center of Tampa, 2719 Nassau St., Tampa, Florida 33607.

The NARHAMS Section of Lanham, Maryland, held its annual election of officers on September 18th. Paul Connor was elected president; Bruce Blackstone, vice-president, Bill Cleary, secretary, Dave Lewis, treasurer; and Jim Barrowman, Senior Advisor.

Plans for the NARHAMS' sponsored East Coast Regional Meet (ECRM-5) are going forward. Scheduled for April 16-18, 1971 at Camp A.P. Hill, the following events have been selected: Scale, Sparrow B/G, Swift Rocket/Glider, Class I PD, Class II Streamer Duration, Hawk B/G, and Parachute Spot Landing. NAR members from Maryland, Virginia, North Carolina, Delaware, West Virginia, and Pennsylvania should contact J. Barrowman, 6809 97th



Photo by W. Arthur
An Estes Mercury Redstone built by Greg Bogoshian lifts off at a recent launch of the Monroe Astronautical Rocket Society located in Rochester, New York. The club, an NAR Section, meets monthly and has been holding launches with about the same frequency. Interested rocketeers in the Rochester area can contact Greg Howick, 2424 Turk Hill Road, Victor, N.Y. 14564.

place, Seabrook, MD 20801, for more information.

Sixth-graders at the Maryvale Elementary School in Buffalo, New York, have been introduced to model rocketry. The program, under the direction of art teacher Anthony Queeno, is designed to link the practical aspects of math and science to the creative aspects of art design. Students are encouraged to design their own models, taking into account both appearance and scientific information on stability.

The Swampscott Engineering Aerospace Team was recently organized in Swampscott, Massachusetts. Interested rocketeers are invited to contact Randy Fogel, 7 Robin Lane, Swampscott, Massachusetts 01907, for more information about the club.

A rocketry club has been organized at the Eastchester Junior High School in Eastchester, New York. The club, under the direction of experimental science teacher Rose Kuczma, now has about 40 members. Recently the club undertook a project to film, in cartoon form, step-by-step rocket construction details. It is planned to make the film available to local school districts as an educational film.

There is beginning to be some model rocket activity at the US Air Force Academy once again. Cadet David Newill, who was
(Continued on page 38)

THE U.S. AIR FORCE'S **TITAN III** 1/100 SCALE MODEL KIT

BUILD TO FLY

BUILD TO DISPLAY



The monster Titan III C... in a great all-plastic, 1/100 scale kit that can be built to display or fly. This super-authentic model features clear heat shield, plated satellites and satellite tower, two fiber inner body tubes, 20" Mylar parachute, NASA markings and much more!
For flying. For display.
The Titan III C from MPC.

For an MPC Rocket Catalog send 25c to:
Rocket Catalog/MPC, 126 Groesbeck Hwy.,
Mount Clemens, Michigan 48043



**MODEL
PRODUCTS
CORPORATION**
Mount Clemens, Mich. 48043



Step into the real world of space

see your hobby dealer



A SUBSIDIARY OF DAMON

DEPT. 31-M / PENROSE, COLORADO / 81240