

# MODEL ROCKETRY

April 1969

35¢

The Journal of Miniature Astronautics

APOLLO 9  
Cape Kennedy Report

SCALE ARCAS

DEMONSTRATION LAUNCHES

SKYRAY TUMBLE ROCKET

TORSION WIRE EXPERIMENTS

R.H. GODDARD  
PAYLOAD ROCKET

HOBBY SHOW REPORT

RELATIVISTIC ROCKETRY

REGULAR FEATURES



# EXPERIENCE

*builds a line of* SCALE MODEL ROCKETS



*Build and fly these SUPER-SCALE models!*

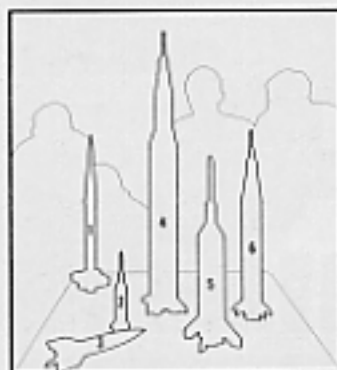

- |                 |         |         |
|-----------------|---------|---------|
| 1 Nike-Smoke    | (1/10)  |         |
| KS-15           |         | \$3.00  |
| 2 Little Joe II | (1/100) |         |
| KS-9            |         | \$3.00  |
| 3 V-2           | (1/40)  |         |
| KS-19           |         | \$3.00  |
| 4 Saturn V      | (1/100) |         |
| KS-12           |         | \$15.95 |
| 5 Little Joe II | (1/45)  |         |
| KS-8            |         | \$12.95 |
| 6 Saturn 1-B    | (1/100) |         |
| KS-10           |         | \$9.95  |

*engines not included in kits.*

Take a close look at the model rockets pictured above. They're fine examples of the new, top-quality kits now available from Centuri Engineering Company. These accurately scaled historical models incorporate ultra-lightweight materials and new simplified construction techniques. Specially molded and formed parts duplicate the exact details needed to win those scale contests and science fairs. They look terrific . . . and fly great too!! All of these and many, many more are included in the world's largest model rocket supply catalog that's just been published. One hundred exciting colorful pages for just a quarter - and we'll refund the quarter on your first order too! Send for your copy today - right now - hurry!!

**Centuri**

Centuri Engineering Co. Dept. MR-1 Box 1988, Phoenix, Arizona 85001

# Model Rocketry

Volume I, No. 6  
April 1969

Editor and Publisher      George J. Flynn  
 Managing Editor          Gordon K. Mandell  
 Business Manager        George J. Caporaso  
 Distribution Manager     Thomas T. Milkie

## Cover Photo

This month's cover photo shows the W.E.T. Centaur 1, launched August 31, 1964, by Charles Walker. A photo gallery feature of his rockets is on page 11. (Cover photo by Charles Walker.)

## From the Editor

The first World Championships of model rocketry will be held in Yugoslavia next year. Will there be a United States team at the championship meet? Will that team be sufficiently skilled and motivated to compete against the best European modelers? Unless planning begins now, our team will not be able to compete against the Europeans.

Two basic questions must be answered quickly. How will the United States team be selected? How will their trip to Yugoslavia be financed?

Otakar Saffek's scale model Saturn V, featured in last month's Model Rocketry, indicates the quality which European modelers are going to bring to the Championships. To compete with them, the USA will have to send its best. To do so, NARAM-11 can be used as an elimination meet to select the US team. But we will not select our best rocketeers this way unless the best modelers from all parts of the country compete at the Air Force Academy this summer. This will require spirited competition in each section during the upcoming contest season to select the best representatives to the Nationals. It will also require guarantees of financial support for those winners to be able to go to Colorado.

On the question of money, a fund, similar to the fund used to send American athletes to the Olympics, should be established. Contributions should be solicited from the hobby manufacturers, major aero-

(Continued on page 32)

The R. H. Goddard: Payload Rocket <i>by Tancred Lidderdale</i>	4
Apollo 9: As We Saw It <i>by Gordon K. Mandell</i>	6
How to Run a Demonstration Launch <i>by Tom Milkie</i>	9
Underground Songs of the NAR	10
The Skyray: Tumble Recovery Rocket <i>by Anthony Pasqualoni</i>	12
The Chicago Trade Show Caper <i>by Secret Agent 002</i>	14
Inertias by Torsion Wire <i>by Gordon K. Mandell</i>	16
The Old Rocketeer: Astroscale Arcas <i>by G. Harry Stine</i>	19
Fundamentals of Dynamic Stability Corrections	28
Relativistic Model Rocketry <i>by George Caporaso</i>	29

## Features

From the Editor	1	Technical Notes	24
Letters to the Editor	2	The Wayward Wind	25
Q&A	8	Reader Design	27
Photo Gallery	11	Club Notes	32

Application to mail at second class postage rates is pending at Boston, Mass.  
 Model Rocketry magazine is published monthly by Model Rocketry, Inc., 595 Massachusetts Ave., Cambridge, Mass. 02139.

Subscription rates: U.S. and Canada, \$3.50 per year; \$2.00 for 6 months; 35 cents for single copies. Foreign, \$6.00 per year; \$3.50 for 6 months; 60 cents for single copies. For change of address please notify us at least 4 weeks in advance. Include former address or mailing label with new address.

Material submitted for publication should be accompanied by a self-addressed, stamped envelope if return is desired. We can assume no responsibility for material lost or damaged; however, care will be exercised in handling.

Undeliverable copies, notice of change of address, subscriptions, and material submitted for publication should be sent to Model Rocketry magazine, Box 214, Boston, Massachusetts, 02123. Advertisers should contact Advertising manager, Model Rocketry, Box 214, Boston, Mass. 02123.

Printed in U.S.A.

© Copyright 1969 by Model Rocketry, Inc.

## SPECIAL OFFER!

Beautiful, full-color photograph of the Apollo 7, Saturn 1B liftoff of October, 1968

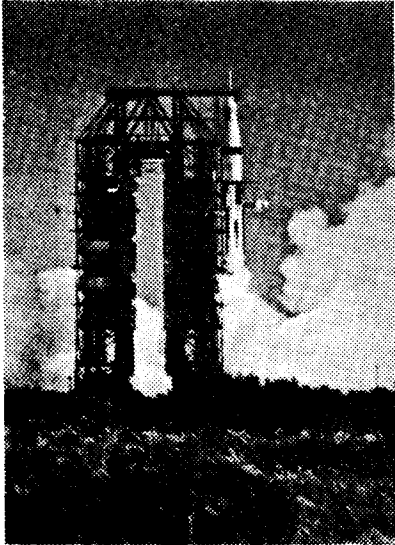

This magnificent photograph of a most historic moment in the history of spaceflight was obtained by Model Rocketry editor George Flynn from an advance position not accessible to most Kennedy Space Center visitors. Showing the moment of liftoff, this 7 by 8 inch full-color print will make an inspiring addition to the album of any space enthusiast.

Full-color copies of the photograph, which is reproduced in black and white above, may be obtained by sending 50¢, or \$1.00 for 3, to:

Saturn Photo  
Model Rocketry  
Box 214  
Boston, Mass. 02123

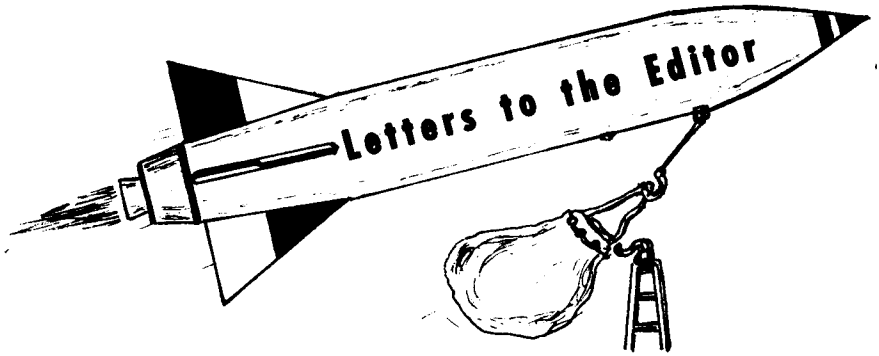

### Wind Tunnels

I wish to thank Mr. Mandell for his prompt reply to my letter on wind tunnels. It was very helpful to me. In answer to his question of what type of wind tunnel article I would like to see, I would have to say a series of articles on each specific part of the wind tunnel. I would like to see blueprints more than a general description. In your January issue I saw some pro and con remarks about your advanced mathematics. I believe model rocketry cannot advance without showing that it's even more than a safe hobby, but a hobby that is training for future scientists. If the math was not a challenge I probably wouldn't have bought a subscription in the first place. By the math being a challenge I feel I will be learning new principles besides learning better to use the old. So I say, keep up the tough work -- I enjoy sweat.

Richard Pattis  
Wilmette, Ill.

*A series of articles on wind tunnels is in preparation, and will probably be featured in Model Rocketry early this summer.*

### Math?

I have just received the January issue of Model Rocketry, and I am delighted with it. I particularly enjoyed the design feature by George Caporaso because it included calculated performance for the Avenger II (as did the Apex in October 1968, which I am presently building).

As for those letters about too much

higher math, I believe such articles as you presented are the main source of progress in model rocketry, and are essential to the attraction of scientists and engineers to the hobby. Though we may not understand the math now (I am a junior in high school) there will come a time when we will. Keep the math coming!

The only articles I had trouble understanding were those on dynamic stability, and even then I got the general idea. Calculating drag coefficients and altitudes were easy to use, if not so easy to understand the derivations of the formulas. These articles can be tested by systematic experimentation and observation, and provide an endless source of inspiration for improvement of individual rockets and of the hobby in general.

I congratulate you on an excellent magazine, and look forward to the next issue.

Mark Johnston  
San Antonio, Texas

### Praise

You gentlemen are to be commended for producing a magazine of this calibre, especially considering that there is no precedent to follow. The content of your articles spans a wide range of interests, and fills a need in documentation of model rocketry.

What is the possibility of using a finer screen to print photos, thus given a better reproduction quality?

Lt. Melville G. Boyd, USAF  
Oklahoma City, Oklahoma

*The use of a finer halftone screen, thus*

Join the.....



**National Association of Rocketry**

1239 VERMONT AVE. N.W.  
WASHINGTON, D.C. 20005

allowing smaller details to be seen in the photographs, is one of the many improvements in the planning stages for Model Rocketry. However, this requires a change in our printing process which would substantially increase our costs. These improvements can only be made when more advertising support is available to the magazine. Readers can help bring about these changes by mentioning Model Rocketry when ordering parts and supplies from model rocket and other major manufacturers. Let them know that their ads in Model Rocketry will help sell their products to you.

#### Arc-Polaris Rocket Club

Enclosed is a photograph of our Sirius 1-F as it lifted off its third and final test flight during June of last summer. The rocket itself stands about four and a half feet tall and is propelled by the Mini-Max engine from Centuri Engineering Company. It has a potential altitude of 3200 feet as calculated on an IBM 1620 here at Eastern New Mexico University, though the best altitude we received from it was about 2400 feet. I might mention that on its second flight it carried two gerbils in its payload sections, and they were returned safely to the ground by a dual parachute system.

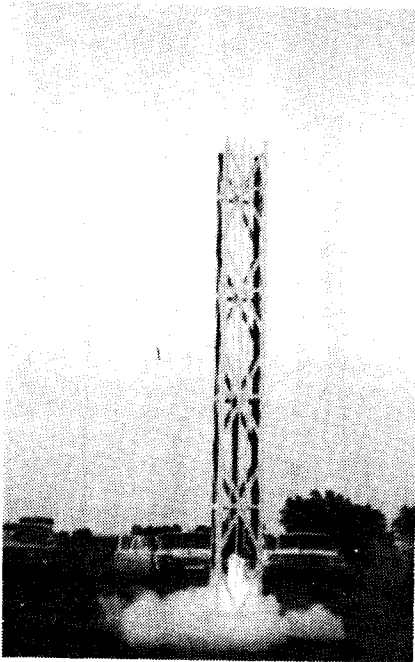

The Sirius 1-F, however, is only one of a series of rockets leading to our Rigel 3-A which we hope will prove to be a reliable launch vehicle for relatively heavy payloads. Other rockets in this series include the Sirius B, the Spica I, the Rigel 1-A, and the Rigel 2-A.

James P. Miller  
Arc-Polaris Rocket Club  
Portales, New Mexico

We hope the Arc-Polaris Rocket Club and all the other rocket clubs in the country will keep Model Rocketry informed of their current activities.

#### Technical Articles

I am a new rocketeer. I just got the first issue of Model Rocketry of my subscription. I have found it to be an excellent magazine. I feel that you should put plans for three rockets in each issue. Keep up the technical articles. I think that they give ample proof that model rocketry is not just a hobby for "little boys."

I would like your help on one matter. When I first started, I only bought supplies from one company. Now I would like to get started in other companies. So could you send me a list of the major companies and their addresses. I would also like to become an NAR member. Please send information on the NAR.

Dave Worth

*As with many of the letters we get, you did not include your address on the letter. Perhaps it was on the envelope, but these often get separated from the letter. You can get full information on the NAR from their offices. Write to: National Association of Rocketry, Dept. MR, 1239 Vermont Avenue, Washington D.C. 20005. The manufacturers are constantly changing; however many of their addresses can be obtained from their advertisements in Model Rocketry and other hobby publications.*

#### Fire and Smoke

Up until now, I have been very pleased with my subscription to Model Rocketry. But, I was shocked by Joel Davis' article in your February issue. Sure, he "signed" a disclaimer for himself and Model Rocketry. But was he trying to be funny?

I take model rocketry seriously, and did not find his examples very amusing. To claim that younger modelers attempt to build nice models for "fiendish pleasures" is really stupid. Funny? No! To claim that we build rockets to hear the "woosh" and see the "fire and smoke" is also somewhat of a fallacy. Funny? No! Also, he mentioned the defunct Prodyne engines detonating during a launch. Model rocketry was just starting then, and a lot of engines were unreliable. Funny? Maybe to a few, but not to a modeler. I have had two rockets destroyed by malfunctioning engines, and it's no fun! If Mr. Davis would like to help model rocketry, he ought to try to help the "budding new rocketeer" instead of knocking him.

Charles Russell  
Hilliard, Ohio

Though the article was intended in a humorous vein, we believe that there is a serious point to be made by Mr. Davis' article.

In fact, a large percentage of model rocketeers first get involved in the hobby in order to "hear the whoosh, and see the smoke and fire." This is evident by the number of rocketeers who quit after a year or two, convinced that there is nothing else to be gained from the hobby.

#### Xaverian High School

In keeping with the theme of our By-Laws, "to promote and foster the exchange of information with other societies engaged in model rocket activities," we enclose our first newsletter of the Xaverian High School Model Rocket Society.

We hope that you may find some use of it in your magazine. Many of us receive Model Rocketry and think that it is excellent and has everything that we enjoy most in model rocketry. We also hope to use some of the equations published by Mr. Caporaso in our GE Time Sharing Computer.

Richard Malecki  
Corresponding Secretary  
Xaverian H.S. Model Rocket Society  
Brooklyn, New York

#### Movie Camera Rockets

I simply love your magazine. There is nothing else like it in the whole universe. I just got my February issue from our hobby store. In this issue, I have found an article that interests me very much. The one on the movie camera on the rocket. I would appreciate the address of this Evan Ravitz so that I may obtain information on his rocket to help in my building one.

Steven Karr  
Yeadon, Pennsylvania

*The only address we have for Evan Ravitz is Croton-on-Hudson, New York. You might try writing to him there.*

*Information on another movie-camera rocket is contained on page 212 of G. Harry Stine's Handbook of Model Rocketry available from Follett Publishing Company, 1010 West Washington Blvd., Chicago, Illinois 60607. Good luck on your project, and let us know how it works out.*

### MODEL ROCKET KITS

Designed for NAR events.  
Great for sport flying.

### Competition Model Rockets

Box 7022 M R Alexandria, Va. 22307  
Send 15c for Brochure

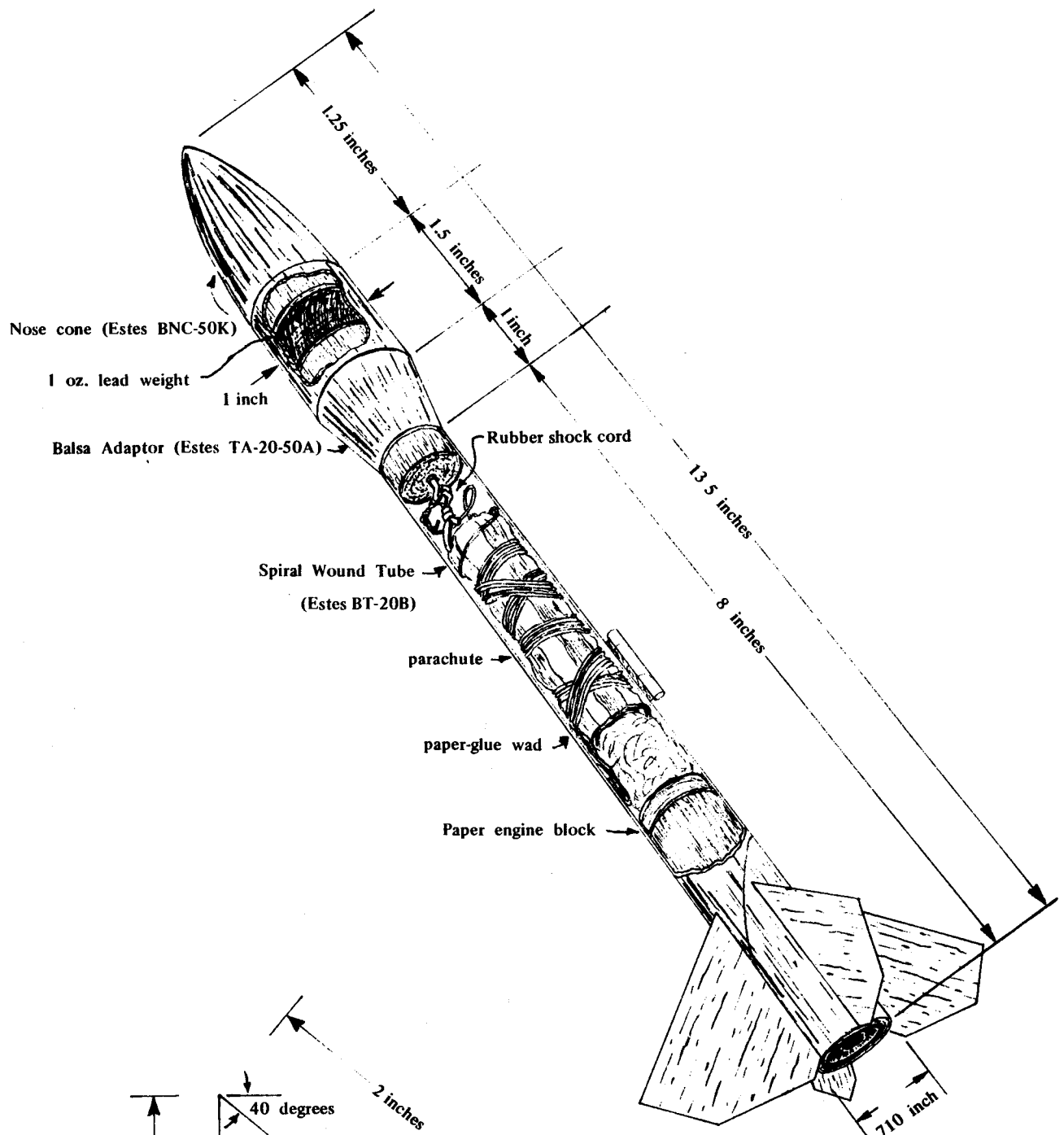

4 fins: 90 degrees apart

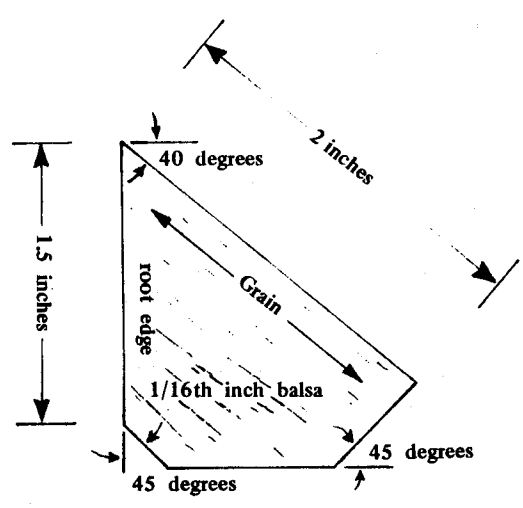

Full Size Fin Pattern

# The R.H. Goddard

## Payload Rocket

by Tancred Lidderdale

The payload competition category is open to models that carry one or more standard FAI-NAR model rocket payloads. In the different classes of competition, for the different size engines, the object is to carry the payload to the highest altitudes. The standard payload is a cylinder of 3/4" in diameter weighing not less than one ounce. It must be totally enclosed within the model, must be removable, at will, must not separate in flight, and cannot have any holes drilled in it to attach it to the model.

Payload competition has lately become a very sophisticated event utilizing only special models. The competition payload model must have low-drag features,

combined with efficiency. The R.H. Goddard model is an excellent example of what is now the ultimate payload design.

Because of the heavy payload weight in the nose, the center of gravity is well ahead of the center of pressure, thus eliminating any stability problem. This does produce a great deal of weathercocking, however. It might even be possible to build a payload bird without fins. The fins are really only required for roll stability.

The number of fins on this model could be reduced to three, if the builder so desires. The design of the fins could also be changed to one's own personal specifications, but I have used this design for years, and I feel it is the most efficient. The relatively small amount of sweep-back provides a very small drag-producing tip vortex.

The optimum of efficiency can be obtained by hollowing out the nose cone and adapter. The most common method is to cut them in half and then carve out the inside. However, you can use a drill to remove the interior so as not to leave a rough, uneven, outer body. If the latter method is used, take care not to get too close to the surface of the nose cone or adapter, because the drill may happen to go through.

The payload shroud should be glued onto the balsa adapter. The nose cone is replaced when the payload is inserted and the cone should have a very tight fit. As an added precaution, if necessary, wrap tape around the nose cone shoulder, until a very tight slip fit is achieved.

The parts shown in the accompanying drawing can be purchased at practically all of the leading model rocket manufacturing companies. An 18" parachute is sufficient for a good landing with a payload inside. The shock cord should be attached to the body by folding a piece of paper (several

times with the shock cord inside).

When you finish the model, the fins and other balsa should first be filled with balsa filler to produce a smooth finish. If a good balsa filler is not available, clear dope can be used, or you could improve this a little by adding talcum powder to the dope. Two or three coats of filler sanded down between coats usually fills the grain of the wood. For competitions such as what this model will most likely compete in, it is best to paint the rocket a fluorescent color. Yellow-orange is the brightest and easiest to see. If you can't get any fluorescent paints then you should use bright red or orange paints.

If you plan to paint the model a fluorescent color, first spray on two good coats of white paint. Then two very light coats of fluorescent paint is sprayed on. To keep the fluorescent paint bright, a final coat of clear dope should be over it. It is best not to add on decals but if you want to add to the beauty of the model small numbers, rivets, and weld details, joint lines, and other markings such as your NAR number can be put on a model using a pen and India ink. A coat of clear dope should be sprayed over these areas to preserve them. A glass-like finish adds to streamlining. Some model rocketeers actually wax their rockets with paste wax to give a very slick finish. This wax also helps if the model lands in wet grass or water. The R.H. Goddard can be flown with a 1/4A, 1/2A, A, B, or C engines. The B14 series engines do not provide the performance that you might expect, so don't cry if someone beats you, using a B6 or B4 engine.

This model is also ideal for entry in the Quadrathon competition. The Quadrathon competition is actually a series of four events: Parachute Duration, Streamer Spot Landing, Class 1 Altitude, and Pee-Wee payload. This event is scored by adding the Parachute Duration time in seconds to the altitude in meters achieved as an altitude model and as a Payload model. The Spot Landing distance in meters shall be subtracted from the score. The entry with the highest number of Quadrathon points is declared the winner. A very exciting contest, I must say, too. The R.H. Goddard model can easily be adapted for use in each separate event.

### PARTS LIST

- 1 BNC-50K nose cone
  - 1 T-50J body tube
  - 1 TA-2050 balsa adaptor
  - 1 T-20B body tube
  - 1 EB-20A paper engine block
  - 1 1/16" x 3" wide balsa wood
  - 1 12" parachute
  - 1 Shock Cord SC-1
  - 1 SE-1 screw eye
- (All parts available from Estes Industries.)

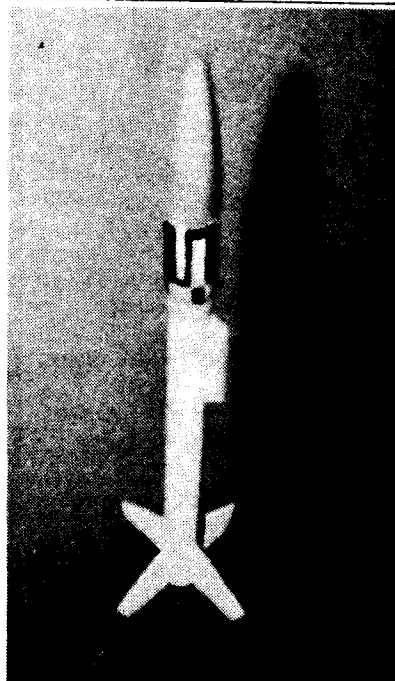

The R. H. Goddard Payload Rocket

# APOLLO 9: As We Saw It!

by Gordon K. Mandell

Mankind took another step toward destiny today with the successful launch from this station of Saturn/Apollo 9. You have by now doubtless read the standard wire-service coverage of the event in your local paper, and our coverage is not intended to duplicate it. Our reporting of the space program is going to be oriented toward giving the readership of *Model Rocketry* some personal insight into the momentous events which mark the Age of Space. I am going to give you a picture of the launch as seen by a reporter who is also a rocketeer.

*Model Rocketry's* coverage of Apollo 9 begins on Sunday, March 2nd. Landing at McCoy Jetport near Orlando, we drive eastward across Florida until we intersect the portion of U.S. Route 1 known as "The Astronauts' Trail" between Cocoa and Titusville. Turning north and proceeding into Titusville, we catch our first glimpse of Kennedy Space Center. There, some twenty-five miles across the mammoth channel joining the Indian River to the Atlantic Ocean, is Launch Complex 39. The gigantic Vehicle Assembly Building, some 500 feet high and encompassing a greater volume than any other structure ever built by Man, is clearly visible despite the predominantly hazy atmospheric conditions. Today Pad A, the closer of the two launch sites in the Complex and the only one as yet fully complete, is in use and the misty majesty of the fully-stacked Apollo-Saturn vehicle soars above the horizon to about three-fourths the apparent height of the VAB. Through 7 x 35 binoculars the high-visibility black-and-white paint pattern is sharply defined and the vertical lettering in red, "USA", can barely be discerned. Though dwarfed by distance, the sight is spectacular to say the least.

Night falls and the launch pad is illuminated by incredibly brilliant xenon lamps. Broken clouds are moving in over Merritt Island and the billion-candlepower beams,

visible for over thirty miles, throw coruscating rays skyward over fifty percent of the heavens' dome. Lest pad electrical power fail, the xenon searchlights are fed from a remote source several miles from the launch site. No other age, no other civilization, no other construction of humanity has ever equalled the pagan pageantry of Pad A this night.

At 8 PM the countdown enters the last of its built-in holding periods. This one will last until 2 AM on the morning of 3 March. Propellants other than the storable hypergolics used in the Lunar Module and the Service Propulsion Subsystem have not yet been loaded, with the exception of the RP-1 used in the first stage -- the S-1C. The high-grade kerosene is normally loaded aboard 126 hours before liftoff and there is no reason I can think of why it could not have been kept on board during the hold initiated on the previous Thursday, 27 February. I decide that it's probably in there, though there is no way to tell simply by looking. Liquid oxygen or liquid hydrogen, were it present, would reveal itself by characteristic steamy clouds venting from pressure relief ports. It is midnight and as yet no such vapors are visible; the first cryogenic loading is scheduled to begin at about 3:30 AM with the admission of liquid oxygen to the tanks of the S-IVB.

4:00 AM, 3 March: *Model Rocketry's* news team awakes. Pad A is still a blazing splendor of light and now, through the 7 x 35's, I can see vapor venting from two locations on the huge rocket. Both the second and third stages are receiving LOX as scheduled. It is still dark; a cloud-yellowed full moon crosses the Indian River with a pallid wedge of light. The ground haze of yesterday has cleared, but the broken overcast may be a problem as the morning wears on.

Down Highway 1 toward the NASA causeway to Merritt Island. Today, because a major launch is imminent, the security checkpoint has been moved from its normal

position internal to the KSC facility on Merritt Island to the causeway station at the Center's outer perimeter. We show our press badges at the causeway checkpoint and proceed, passing the signs reading "Merritt Island Game Preserve", along the roadway to Complex 39. The VAB looms up ahead, a huge, spotlight-studded cliff. Although it is impressive enough from the outside, I am told that its true immensity can only be appreciated by looking down from the upper-level catwalk inside. Time enough for that later; it is nearly 5:30.

Turning in toward the press site, we see the Saturn close up for the first time. There, a scant fifteen thousand feet across the towing basin and down the crawlway, stands the mightiest engine ever wrought by the hand of Man. The gray servicing gantry has been pulled away during the night and all that remains is the red Launch Umbilical Tower, standing to the left of the rocket. Rocket and tower are still enveloped in a pristine xenon glow and the cryogenic venting, startlingly white, is clearly visible to the naked eye. Under 7-power magnification every detail on the vehicle stands out.

The forward perimeter of the press site is bounded by a row of four-by-fours, painted white and driven into the sandy ground. Here we set up our photographic equipment. Although my task is to film the liftoff with a telephoto-lens equipped 16-mm motion picture camera, I have been taking 35-mm stills all along. At this distance a 45-mm lens produces a minuscule image, but I try the pictures anyway. The flightcrew -- James A. McDivitt, David R. Scott, and Russel L. Schweikart -- are awakened at 5:45 and at about the same time liquid hydrogen fueling of the S-II and S-IVB stages is initiated. By 6:00 the Eastern sky is brightening; at 6:30 it is nearly full daylight. There has been no visible sunrise. The 3/10 cloud cover is heavily concentrated in the East, behind and just south of the pad. Just before 7:00 the pad lights, now barely



visible, are extinguished. The flightcrew will soon be leaving their quarters to board the ship.

To catch this part of the prelaunch procedure we must drive several miles back across the base to the News Center, at which special press buses will be waiting to take us to the crew quarters. Model Rocketry Editor George Flynn and I are lucky enough to catch the second bus, which leaves at about 7:30, and so to obtain good positions at the rope barrier surrounding the transport van boarding area. Newsmen continue to arrive and their ranks are swelled by NASA employees until the crowd at the rope totals 150 or so. Still other employees look down from windows in the upper stories of the building in which the crew quarters are housed. The fueling is running about ten minutes late and there is a delay in calling the crew to the pad, during which Alan Shepard, wearing a maroon sweatshirt, comes out to speak quietly with the personnel near the van and a few of the newsmen.

Shortly after 8 AM the door to the building opens; a hundred cameras are raised as one. The flightcrew, clad in suits and helmets, emerge and walk briskly toward the van. The crowd begins to applaud and some of the Grumman Aircraft on-site staff hold up a sign with their best wishes written on it in red crayon. I have the other movie camera (the one without the telephoto lens) grinding away; through the viewfinder I can neither tell the astronauts apart nor identify those who accompany them. About halfway to the van the men wave briefly, then continue through its doors and disappear from sight. After a brief pause the van moves off.

Back at the press site representatives of the media are arriving in increasing numbers. Tripods ring the forward perimeter. I am told that coverage of this flight is going to be relatively light and wonder what *heavy* coverage would look like. About 9 AM the sun breaks through the clouds, raising hopes that we will have clear weather for a launch and bathing the distant ship in golden radiance. Our optimism is short-lived; the clouds begin to close in from the west and by 10 AM we have solid overcast. There is some concern that the launch may be scrubbed.

At 10:01 Launch Control comes on the horn with a report of "go for the mission.... We have a forecast of overcast in the Cape Kennedy, the complex 39 area, but it is acceptable for launch." The ceiling is 4500 feet; this must decrease to 2000 before a launch is scrubbed. The Public Affairs Officer reports that propellant loading is complete, that the spacecraft was completely boarded by 8:40, and that it was sealed at 9:20.

Until this time the countdown has seemed to drag slowly along, with more than enough time between events. Now, as it enters the final hour, its tempo accelerates

tenfold. PA announcements begin coming at intervals of a few minutes: T -49 minutes, T -44, -39, -34, -29. The press site stirs as the newsmen begin making adjustments to their optical and audio equipment. Some have second thoughts about the position of their instruments and run here and there changing the location of their tripods.

T -19 minutes. I am worried about steadying the movie camera during the lift-off and try to find a position in which I have the camera under vibration-free control. Lying on my back at the edge of the perimeter with my head propped up on an overnight bag seems to do the job; at lowest elevation I can just bring the rocket into the field. The sky is still overcast.

T -5 minutes. The press site is growing quiet now; the only activity is final equipment adjustment. The immediacy of launch brings with it a subdued atmosphere, against which the announcements of the PAO are doubly loud.

T -3 minutes, 7 seconds. The automatic launch sequence is in effect. From this moment on, if all goes well, no human hand will command the booster. I find the rocket with the camera again, just for practice. It takes about 20 seconds. For an awful moment I think I've forgotten how to operate the spring motor and fumble with the controls until I relocate the right one. Not a sound now except the voice of the PAO.

"T -55 seconds and counting. All going well, we are coming up on the power transfer. Mark 50 seconds and counting, we're now on internal power with the three stages and instrument unit of the Saturn V."

I start looking for the ship in the finder.

"All propellant tanks in the second stage now pressurized. 35 seconds and counting, the vehicle now completely pressurized, ..."

Where is it? *I can't find it!*

"...vents closed, we are GO, 30 seconds and counting. T -25 seconds and counting, all aspects still GO at this time as the computer monitors."

*There it is!* O.K., keep it, keep it, steady...

"Twenty seconds, guidance release, 15, 14, 13, 12, 11, 10, 9, ..."

A flicker appears at the rocket's base; it grows to a ball of orange flame, then a fiery torrent.

"...we have ignition sequence start, 6, 5, 4, ..."

I start the Wollensak rolling, then realize the Saturn fills more than the full field. *Which end do I want?*

"...3, 2, 1, zero. All engines running. Commit, liftoff. We have liftoff at 11 AM Eastern standard time."

The spaceship rises from the pad, inundating the structure in flame, and makes my decision for me: I will track the after end until the full length is visible. The initial motion is majestic, but the subsequent acceleration is surprisingly rapid. The flame is

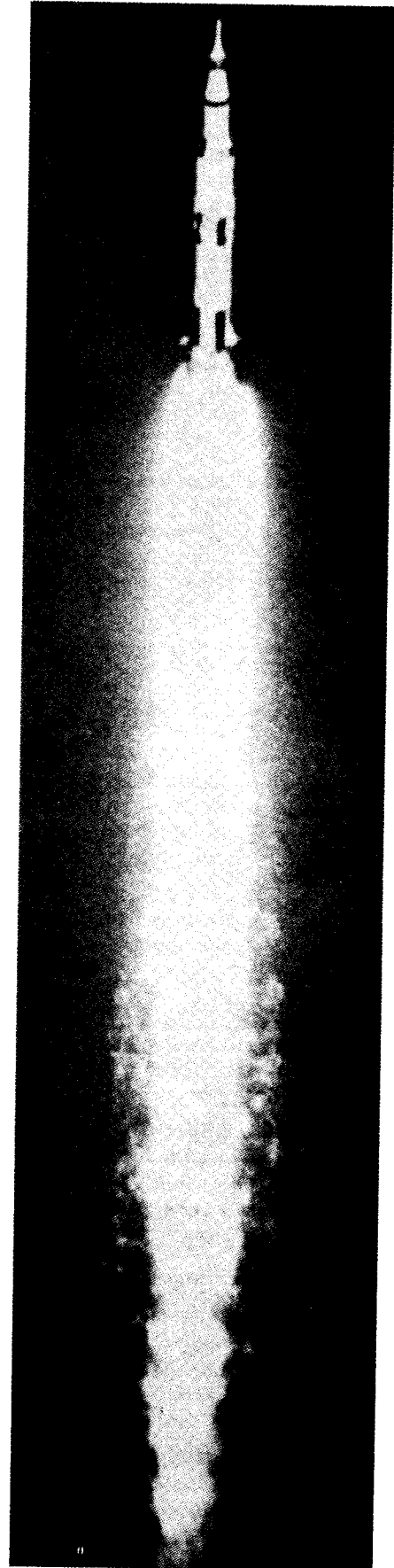

NASA Photo

redder than in any picture I have seen, redder than I expected. I can feel the heat, just barely.

Then the sound hits. Sound isn't the word for it; it's much too intense and its frequency is too low. It's more like a series of closely-spaced shock waves that sounds like a cross between thunder and a powerful stereo set, turned up all the way, with coarse sandpaper being drawn slowly across the needle. It shakes the ground, making it hard to steady the camera; I'm being bounced around like a pebble on a drum-head. The corrugated roof of the grandstand adds its tinny resonance to the din.

The whole bird is in the frame now, the whole bird and the exhaust...exhaust looks about a thousand feet long, more orange and more ragged than I expected. Some of the flame end appears to detach periodically from the main exhaust and stand off in patches. The ship seems to claw its way skyward, assaulting the heavens. Noticeably foreshortened, it is rolling slightly and tipping from the vertical.

"...Plus 17 seconds, the roll and pitch programs are in now to put Apollo 9 on the proper flight azimuth and attitude. Half a mile high, roll is complete."

*It's GONE!* Gray oblivion has traversed the length of the vehicle; in two tenths of a second it has erased the ship from nose to tail, lighting the sky in a brief flash as it swallows the exhaust. After twenty-three seconds of visible flight, the rocket has passed through the clouds. The thunder of the exhaust momentarily increases, then begins to drop off again, fading into the distance as her mighty engines drive Apollo 9 on to orbit.

Drifting slowly northward from Pad A is a huge cloud of black kerosine smoke from the ignition; a fainter trail towers from the pad to the base of the clouds. Nothing else remains to mark the rocket's passing.

## q & a

Please print a circuit diagram for a simple model rocket ignition system.

**Paul Karanevich**  
Brooklyn, New York

Since you asked for emphasis on the circuitry system, I have prepared the diagram using standard electrical symbols rather than just drawing a picture of a rocket hooked up to an electrical firing system.

If you are going to use a car battery to fire your rockets, you will need some means of attaching the wires going out to the rocket to the large terminal posts of such a battery. Large copper "jumbo clips" available in hardware stores and from some

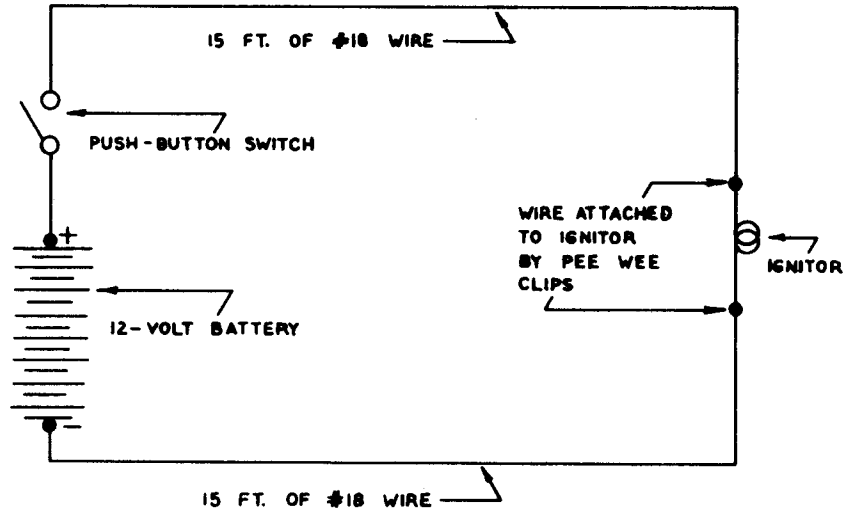

model rocket manufacturers are good for this purpose. From one of these clips run a length (15 feet or so) or No.18 AWG insulated wire out to the rocket, soldering a "pee wee" clip to the end of the wire that will be out at the rocket. The pee wee clip, a small alligator clip with flat jaws, is needed to attach the wire to the thin wire of which the rocket ignitor is composed. From the other jumbo clip run a short length of wire to one terminal of a push-button switch. This switch should be the type that closes a circuit when pressed, but returns to the open-circuit position when released. Such a switch is referred to as "SPST, normally-open." From the other terminal of the push-button switch run another length of No.18 wire out to the rocket, soldering a pee wee clip to the rocket end of this wire also.

This is a rather simple system, and for extra safety you should leave one of the jumbo clips unclipped from the car battery when hooking up a rocket to fire. To fire a rocket with this system, prepare it and insert the ignitor according to the manufacturer's instructions. Two short lengths of thin, bare wire will now be protruding from the nozzle of the rocket motor. Place the rocket on its launcher and attach one of the pee wee clips from your firing system to each of these ignitor ends, taking care that the ignitor ends don't touch each other, the pee wee clips don't touch each other, and neither pee wee clip touches any metal part of the launcher. Now attach the jumbo clip which you have left unclipped to its terminal of the car battery, so that each jumbo clip is attached to one of the battery terminals. From this point on you must remain in the vicinity of the battery and push-button switch and must not approach the rocket, for the circuit is armed. In order to fire the rocket, announce to anyone in the vicinity

that the circuit is armed and a firing is imminent; then give a five-second count-down and press the push-button switch. This will close the circuit and cause current to flow through the ignitor. The ignitor, which is a resistance element, will then become hot and ignite the propellant grain of the rocket motor.

The system I've described is just about the simplest and least expensive one imaginable (unless you're going to buy the car battery!), but it is by no means the only arrangement possible. Many refinements, described in past issues of **Model Rocketry** can be added to the basic firing system to increase its safety, reliability, and firing capacity. Many different batteries can also be used; a car battery is not the only possibility and is in fact probably not the best way to go for a single-launcher firing system. Four photo-flash batteries in series, the 6-volt system used in prefabricated launchers, also work fine as does a 6-volt "hot-shot" lantern battery or four sintered nickel-cadmium cells in series. There are also some very fine lead-acid wet-cell rechargeable batteries on the market which are much smaller and lighter than car batteries yet powerful enough to launch many rockets before they need recharging.

Watch the pages of **Model Rocketry** for the latest advances in ignition technology.

*Any questions submitted to this column and accompanied by a self-addressed, stamped envelope will be personally answered. Questions of general interest will also be answered through this column. All questions should be submitted to:*

*Q and A*  
**Model Rocketry Magazine**  
Box 214  
Boston, Mass. 02123

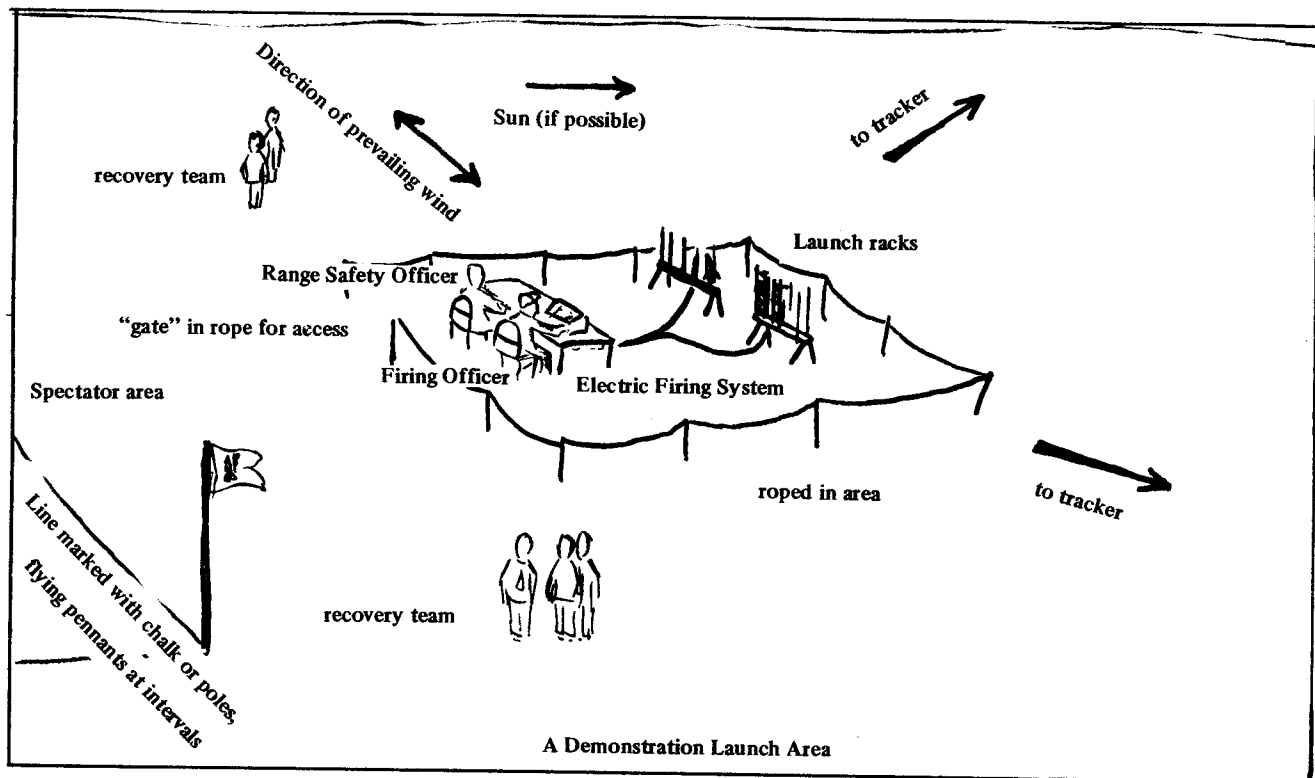

# How to Run a Demonstration Launch

by Tom Milkie

Demonstration launches are held by many clubs from all over the country. There are many reasons for running a demonstration. It may be to help with a membership drive. Sometimes a demonstration is just the thing to convince people of the *safety* of model rocketry. If your club has to convince school officials to become a recognized activity, or convince your police department or fire chief of safety, a well run demonstration is ideal. Even if you have lots of members, are recognized by the law, and have a large launch site, it would still help your club's public relations to put on a show. You might even convince some person or organization to pay for your new wind tunnel or launch equipment.

Where should you hold a demo? At any major outdoor public gathering you will already have a crowd and probably a good launch site. At picnics, social festivals, football or baseball games (before or after the

game—maybe even as a half-time attraction). However, try to steer clear of carnivals where you might get an image of a bunch of kids playing with fireworks. And of course, *never launch as a Fourth of July attraction!*

If you are ambitious enough your club can run a launch completely separate from any event. For this you will need plenty of advertisement. Announcements should be placed in the local newspaper, your school paper, or on a local radio station. Really flashy posters can be put up at school and in store windows if they are permitted. If you can get a few adults interested it might be possible to get a civic club to advertise and run your launch for you.

Your launch site can be any moderate sized field, for you won't be launching in high winds or shooting for high altitudes. A football field, complete with bleachers for the crowd is ideal, and there is one at nearly every high school. Bleachers available in

sporting fields are a great help in controlling the crowds also. If you are really stuck, a large shopping center parking lot is usually vacant on Sundays and holidays and can be used.

Regardless of where you launch, be certain to get an official OK from the law and the owner of the property. The launch area should be a good distance from the crowd and *must* be roped off. To help draw attention to the restricting rope and make it look flashy, short pieces of streamer material or plastic banners can be attached. Someone must be appointed Range Safety Officer. He should stop the launch at any time that an unsafe situation arises, such as when a child wanders out into the launch area.

The rockets used in the demonstration are very important. Every one should be *stable, reliable, and have flown before*. A 7 engine 3 stage cluster may have worked the

last time you launched it but the risk of something going wrong is not worth the showyness of the flight. You will probably find that even with simple rockets a public demonstration always follows Murphy's Law: "Whatever can go wrong, will go wrong." Don't attempt to launch any high altitude rockets—the crowd will have to follow the small rocket and, more importantly, your club will have to recover it when it comes down. Use rockets that are painted well for visibility and to impress the crowd. Scale birds would do nicely if they are reasonably stable.

All rockets should be ready for launch so as not to keep the crowd waiting. Engines should be selected, taped for fitting, and igniters installed beforehand. Parachutes should not be stuffed into the rockets until soon before the launch. Otherwise the plastic will stick to itself and the chute will not open. The ignition should be checked over before the show to insure against electrical failure when everyone's waiting. (remember Murphy's Law.) The igniter clips should be well sanded and sanded before every launch. The power supply really should be a storage battery, well charged, to insure good ignition of clusters.

Even with all safety precautions don't forget that you're putting on a show. If your club doesn't have one you should make a flag with your club's emblem on it. If your club members have club shirts they should of course all wear these. A display booth with experimental rockets, competition trophies, samples of engines and explanations of how everything works should be set up outside the ropes. The PA system run by the launch officer adds the finishing touches with a warning and short countdown before each launch.

(New Product Notes continued)

capsule. This scale model designed to be powered by a single engine, comes with a historical data booklet for \$3.00. The Saturn IB, standing 26.8 inches tall, has the same easy construction features as the Little Joe II. Quick change engine mounts and removable display nozzles make this model suitable for either display or flight. The Saturn V model, also designed to the exacting standards of a display model but fully outfitted for flight, is 43.6 inches tall and powered by 3 engines. A historical Saturn data booklet accompanies each of the Saturn models. The prices are \$8.95 for the Saturn IB and \$15.95 for the Saturn V.

For boost-glide enthusiasts, the Swift front engine, pop-pod boost glider was introduced. This rocket, with a 16 inch wing span, is recommended for the experienced modeler. The price is \$1.95. For those who like the unusual, build the Point — an 8 inch long, cone shaped rocket with a maximum body diameter of 3.9 inches. This kit comes with a pre-painted body skin and an astronaut cockpit for only \$1.50.

## The Underground Songs of The NAR

*The Underground Songs of the NAR were snatched from an underground song sheet and from hidden tape recorders at NARAM-10. The persons, places and events described are purely fictional (unless you know otherwise). From time to time Model Rocketry will publish selections from the underground song sheet.*

### BARROWMAN

(Tune: "Green Back Dollar")

When I was a little baby

My mam said, "Hey, son,

Travel where you will and grow to be a man,

But watch out for Barrowman, poor boy,

Watch out for Barrowman!

And he don't give a damn about his own calculations,

Adds 'em as fast as he can.

For a 2 and a 3 make a definite 7.

Watch out for Barrowman, poor boy,

Watch out for Barrowman!

Maybe it was the computer,

IBM or RCA,

But if you fly a rocket built by that method

Better take cover I say, poor boy,

Better take cover, I say!

And he don't give a damn about his own calculations,

Adds 'em as fast as he can.

For a 20 and a 12 make a definite 18,

Watch out for Barrowman, poor boy,

Watch out for Barrowman!

The CP's in front of the nose,

The CG's behind the fin

That's the result on a little WAC Corporal,

My scale is out on a limb, oh boy!

My scale is out on a limb!

And he don't give a damn about his own calculations,

Adds 'em as fast as he can.

For a 50 and a 90 make a definite 72,

Watch out for Barrowman, poor boy,

Watch out for Barrowman!

When you pick up all the pieces

And shovel them into a pail,

Then you've finally realized that

A fool-proof system can fail, and how!

A fool-proof system can fail!

And he don't give a damn about his own calculations,

Adds 'em as fast as he can.

For a hundred and a 20 make a definite 43,

Watch out for Barrowman, poor boy!

Watch out for Barrowman!

# PHOTO GALLERY

*Readers are invited to submit photographs of their model rockets for publication on this page. Our staff will select those photographs having superior quality and composition for inclusion in the Model Rocketry Photo Gallery. Send your photos to:*

*Photo Gallery  
Model Rocketry  
Box 214  
Boston, Mass. 02123*

Photos by Charles Walker

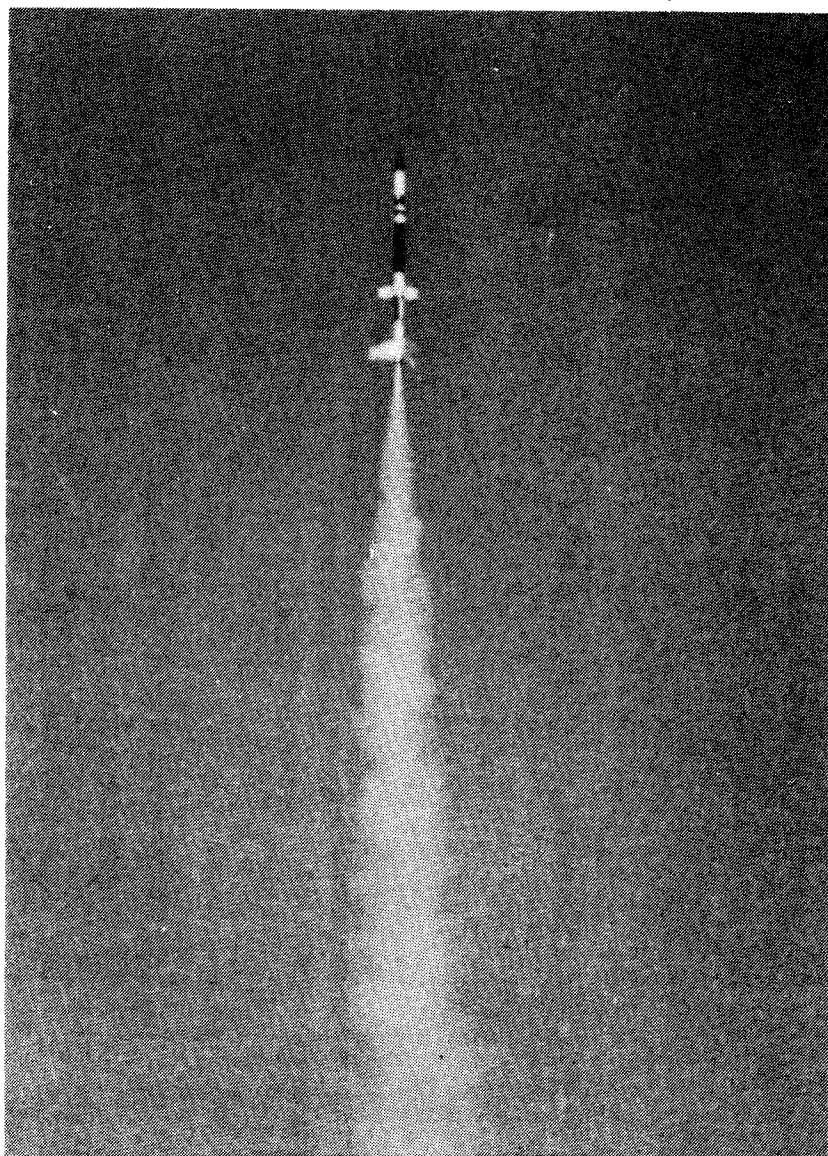

Nose cone (Centuri BC-70)

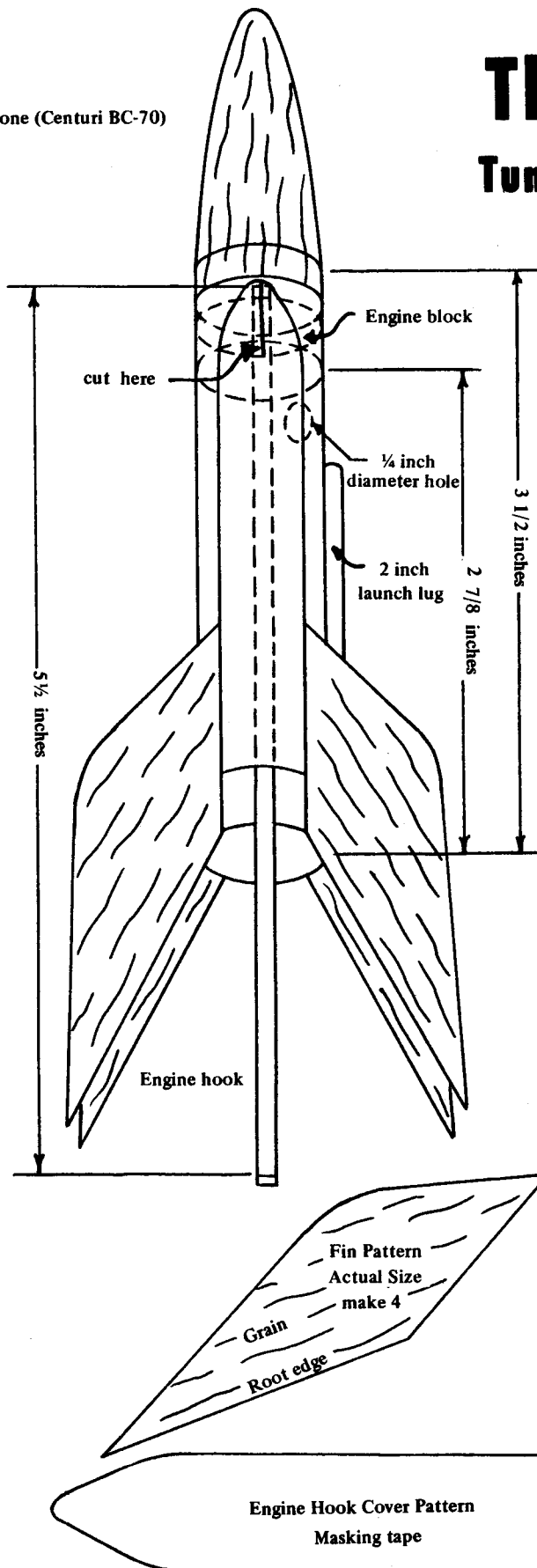

# The SKYRAY

## Tumble Recovery Bird

by Anthony Pasqualoni

The "Skyray" is a high-altitude tumble-recovery model rocket. Tumble recovery in this model is accomplished by moving the CG of the rocket rearward. After burnout and coasting, the ejection charge forces the engine back against the engine hook. This shifts the CG rearward. Now since the CG is now behind the CP, air pressure is greater up front of the rocket, and so the rocket starts tumbling. This causes the rocket to slow up enough to permit a safe recovery.

This design was accomplished by the use of Estes Industries Technical Report No. TR-9, **Designing Stable Rockets**. The design was tested before flight by using the "string method" described in Estes Industries Technical Report No. TR-1, **Rocket Stability**. The rocket was test-flown, and performed beautifully.

### ASSEMBLY INSTRUCTIONS

- 1) Cut a straight 6 inch piece of wire from a wire hanger. With a pair of pliers form a ¼ inch long right angle hook on each end.
- 2) Punch a hole in the body tube 1/8 inch down from the top of the tube with the end of the engine hook.
- 3) Apply glue to a depth of ½ inch inside the top end of the body tube. Insert the engine block into the top end, and insert the nose cone on top of it.
- 4) Using the engine hook, punch a hole in the nose cone through the hole in the body tube. Withdraw the hook, squirt glue in the hole, and replace the hook, lining it up parallel with the body tube.
- 5) Cut a 2½ inch piece of ½ inch wide masking tape. Lay it over the engine hook and wrap it around the tube ½ inch from the bottom.
- 6) Trace the engine hook cover pattern onto heavy typing paper and cut it out. Cut a ¼ inch long slit in the tapered end of the cover, apply glue to the back, and place it over the engine hook with the slitted end even with the top of the tube.
- 7) Trace the fin pattern onto the 1/8 inch balsa fin stock. Cut out the fins. Round all edges of the fins except the root edge, which should be squared. Glue the fins to the tube and, after the glue has dried, apply two heavy glue fillets to the fin-

body joint.

- 8) On the side of the body tube opposite the engine hook, and about 1 inch down from the top of the tube, cut a 1/4 inch diameter hole. This allows the ejection gases to escape after the engine has been forced rearward.
- 9) Glue the launch lug to the body tube.

#### FLIGHT INFORMATION

Recommended engines for this model are 1/4A3-2, 1/2A6-2, A5-4, A8-3, B4-4, B6-4, and C6-5. Insert the engine without friction-fitting. Use a standard 1/8 inch diameter rod. Use 1/2A6-2 for normal flying.

#### PARTS LIST

- \*3 1/2 of .736" diameter body tube
- \*Centuri BC-70 nose cone
- \*1/8"-thick sheet balsa
- \*2 1/2" launch lug
- \*Engine block
- \*1/2"-wide masking tape
- \*Heavy typing paper
- \*A thin wire hanger
- also
- \*Pliers
- \*Extra-sharp modeling knife
- \*Scissors
- \*Extra-strong white glue
- \*Sandpaper

Say you saw it in

# Model Rocketry

## SOLICITATION OF MATERIAL

In order to broaden and diversify its coverage of the hobby, MODEL ROCKETRY is soliciting written material from the qualified modeling public. Articles of a technical nature, research reports, articles on constructing and flying sport and competition models, scale projects, and material relating to full-scale spaceflight will be considered for publication under the following terms:

1. Authors will be paid for material accepted for publication at the rate of two dollars (\$2.00) per column inch, based on a column of eight-point type thirteen picas wide, for text, six dollars fifty cents (\$6.50) for drawings, and two dollars (\$2.00) for photographs accompanying text. Payment will be made at the time of publication.

2. Material submitted must be typewritten, double-spaced, on 8 1/2 by 11 inch paper with reasonable margins. Drawings must be done in India ink and must be neat and legible. We cannot assume responsibility for material lost or damaged in processing; however our staff will exercise care in the handling of all submitted material. An author may have his manuscript returned after use by including a stamped, self-addressed envelope with his material.

3. Our staff reserves the right to edit material in order to improve grammar and composition. Payment for material will be based on the edited copy as it appears in print. Authors will be given full credit for published material. MODEL ROCKETRY will hold copyright on all material accepted for publication.

Those wishing to submit material should send it to:

Editor

Model Rocketry Magazine

P.O. Box 214

Boston, Mass., 02123

# The Chicago Trade Show Capers or Secret Agent 002 Strikes Again

Each year, the Hobby Industry Association of America (HIAA) holds its annual trade show at the Sherman House in Chicago. Here, all the hobby manufacturers reveal their super-secret new products for the coming year. It attracts over 5000 hobby wholesalers and dealers, includes every major hobby manufacturer in the world, and is practically impossible to get into. The general public is not permitted past the gimlet-eyed armed guards blocking the doors. You gotta be a member of the HIAA— which restricts its membership to manufacturers, wholesalers, dealers, and manufacturing representatives— or a legitimate hobby dealer.

However, by dint of superhuman effort, your hard-working spy, otherwise known as Secret Agent 002, slithered through an air-conditioning duct, self-destructed his tool kit, donned a hobby dealer's suit, and proceeded to spy.

HIAA has a new Model Rocket Division headed by Tim Skinner of Model Rocket Industries as Chairman; Vern Estes as Vice-Chairman (obviously, the best man to put in charge of vice); and Frank Voigt of Laurel, Maryland (a hobby dealer) as Secretary. This year, they set up a special Executive Committee headed by Leroy Piester of Centuri Engineering Company to work with the NAR in the development of a joint NAR-industry Safety Code. So, us model rocketeers do have a voice in HIAA affairs.

But it was the Trade Show that attracted our spying eye. It covered one whole floor of the hotel, and part of another— including the Grand Ballroom, the lesser ballroom, and anyplace else they could manage to jam in another display booth. Just being in the same place with all those goodies would drive any model builder off his bird, believe

me! Kits, parts, accessories...it was like the world's biggest and most complete hobby store. Glorious! Except, even if you had a million bucks you couldn't buy a thing! Everything is for display only. If you want to order 300 gross of something, a manufacturer would gleefully write up your order and promise rapid delivery upon the release of the kit next October!

In fact, sometimes a kit item shown at the HIAA Trade Show is simply a mock-up. The manufacturer may not have even designed the final product yet! And he may never do so, if he doesn't get enough orders for it at the Trade Show. After all, there is no sense in spending the money to put a kit on the market if you haven't got any orders for it, is there?

We prowled through the displays, trying to act like somebody who would buy 300 gross of something. Because, if we had said, "Oh, we're just looking," we might have been heaved out. We were particularly interested in anything that had to do with rockets, astronautics, or space.

And there was plenty of it this year!

MRI (Model Rocket Industries) was the only model rocket manufacturer displaying this year. Mike Bergenski and Ron Day have developed some interesting new products for 1969— a new launcher and firing system, for example. Due for release in April, this futuristic design shows that model rocketry has come a long way from the days when a launcher was a rod stuck in a block of wood. In the way of models, MRI will add to their line with the 3-stage Microsonde model in March, the Megas cluster payload model in April, and a 2-inch diameter Saturn V scale model in June. Also new from MRI are two "customizing kits" which contain enough materials, components, and

MRI-created plans to build three complete and different models...and the modeler will also have the option of designing his own futuristic models with these customizing kits. This, of course, is following the trends established in model aeronautics and model cars. For 1969, MRI also promises new nose cones, body tube sizes, adapters, etc.

In the area of non-flying or "static" kits, the big plastic manufacturers pretty well dominate the scene. Some firms are dusting off the molds of the old plastic rocket and missile kits they brought out a decade ago, putting them in new boxes, and calling them by new names. We saw a lot of old kits that are being released again. In some cases, these cannot be made to fly, but lots of them can...and the NAR Plastic Model Event is probably going to be given a shot in the arm, so to speak, by this.

Revell is coming out in November 1969 with a huge 1/96 scale model of the Saturn V; this monster will be nearly 4 feet high! Chances are that it can be converted to fly with large engines, or clusters of smaller ones. In August, Revell will release a 1/24 scale model of the Soviet Vostok space capsule (not the entire rocket). Revell's president Lew Glaser was non-committal about reviving the Revell V-2 kit, however.

But there *is* a German V-2 kit available, if your hobby dealer can obtain Faller kits. This German plastics firm has had a combination kit of the V-1 plus the V-2 in 1/100 scale available for some time. It is Faller Kit Number 1944, and sells for \$2.50. In 1/100 scale, it is too small to fly with any current model rocket motors, but the kit makes a fine static display model.

By this time, you've probably seen Monogram's 1/144 scale plastic model of the Saturn V. The corrugations around the S-1C and S-II stages are not exactly correct, and the engine cluster on the S-II leaves something to be desired, but it's a nice kit and should be fairly easy to convert for flight. Monogram is also dusting off and revising their 1959 Missile Arsenal Kit, eliminating some vehicles and adding some new ones, to create their 1969 Space Vehicles kit; most of these are too small to fly because the scale is 1/128.

Model rocketeers will be delighted with AMT's manned space vehicle kits. In 1969, they will release scale static plastic kits, all in the same scale, of the Mercury-Redstone, Mercury-Atlas, Gemini-Titan, Apollo-Saturn-Ib, and Apollo Saturn V. There were only mock-ups of these kits on display, so it

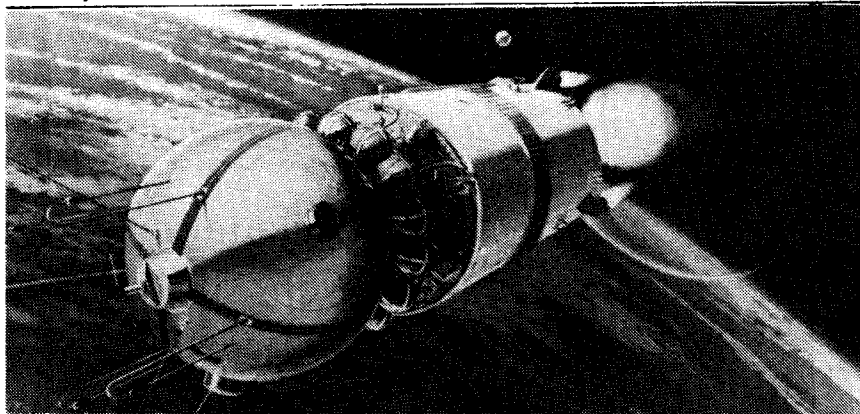

Revell's Vostok Reproduction



was impossible to tell whether or not they could be flight-modified. Hawk, of course, revived their 1/48 Jupiter-C kit in 1967, and this is still available in 1969; it modifies for flight easily, especially for the new Estes C6-5 motors. Hawk has a number of static models of interest to rocketeers--the Japanese Oka (Baka), the German V-1 in 1/48 scale, the Explorer 18 and Vanguard satellites, and the revived MOL kit based on Krafft Ehrlicke's manned Atlas orbiting lab of 1959.

The big whoopee-twang gee-whiz kits for 1969 seem to be nutty space vehicles customized from leftover slot-car equipment, and these will be good for thousands of belly laughs in the local model rocket club. However, Aurora Plastics is bringing out the Space Odyssey "Moon Bus" plus some vehicles from popular TV shows such as the "Voyager" from "Fantastic Voyage", and the spaceship from "The Land of the Giants." Have fun!

There was some equipment on display in Chicago that is intended for use in model aviation or other areas that would be great for model rocketry. For example, Bersted's Hobby Craft, Box 40, Monmouth, Illinois 61462 displayed its "Sabre-Lathe," a 3-speed miniature lathe that would be just great for custom model rocketry work, since it could turn nose cones, boat-tails, or entire model bodies with its 18-inch bed and 4-inch swing. It goes for about \$50.00, which is cheaper than the more elaborate Uni-Mat by a factor of 3, and is probably the cheapest small lathe now available.

For those of you who like to build scale launch complexes and gantries, you can now get scale structural shapes molded in plastic from Plastruct, Inc. at 1621 North Indiana Street, Los Angeles, California 90063. These are various-sized I-beams, angles, hat sections, z-sections, etc., extruded from plastic that is lots stronger than shaped wood and much easier to assemble than brass shapes. The plastic can be bonded with nearly any plastic glue and can even be bonded to wood and paper with ordinary glues. By using a contact cement such as Pliobond, it can be bonded to metal. Because of the type of plastic used, these shapes can be painted with ANYTHING, including dope. You can also get scale piping, valves, etc., which will add to the appearance of your launchers. This stuff has been used for years by professional model-makers and architects, and it has just become available to hobbyists such as ourselves.

Top-Flite's MonoKote is probably the answer to a model rocketeer's prayer. You can get an absolutely perfect finish on a model in nearly nothing-flat. Now, Top-Flite has come out with metallic colors, as well as transparent colors. The various types of MonoKote are also great for making your own decal-like details, because you can cut the shape out of MonoKote or Super MonoKote and stick it on. Good news includes

the availability of smaller pieces of MonoKote so that you don't have to buy a whole \$3.50 sheet of the stuff at once. As you probably know, one big sheet of MonoKote will cover approximately 14,564.85 average model rockets.

Finishing Touch Decals are coming out with more and more types of decal sheets, and confied to Secret Agent 002 that they were considering decal sheets for various space vehicles and rockets, too. However, you can stick your NAR number on your models with any of the various number decal sheets now available from Finishing Touch.

Good news for those of you who have been looking for a battery-operated public address amplifier to put in your club firing panel, or searching for communications equipment so that you can set up tracking stations. All kinds of electronic kits are now becoming available. Solid-state electronic kits from EicoCraft that will be of interest to modrocketeers include the EC-600 light flasher, the EC-100 Siren, the EC-200 battery-operated intercom, and the EC-300 2-watt PA Amplifier. EicoCraft also makes the EC-2400 Bullhorn. From Mod-U-Kits of Roselle, New Jersey, there is the CBT-1 Citizen's Band transmitter kit (could be flight modified), the IA-2 intercom amplifier kit, the MPA-5 mobile power amplifier kit, various tiny receiver kits, and a slug of power supply kits.

The general interest in model rocketry in the hobby industry is very great and growing all the time. A number of very prominent firms have expressed an interest in "getting in." As your secret agent man, I intend to keep spying on them. Model rocketry could be set back several years, if a fast-talking outfit "got in" and swamped the discount stores and serve-yourself hobby operations with completely pre-fabbed, shake-the-box-and-fly-it model rockets that might be unsafe in flight. As a matter of fact, it could be quite troublesome for all us modrockers if new manufacturers do not follow the NAR standards all the way.

By and large, the hobby industry has not really changed very much in the past decade; there are just new products. But we're probably going to see a lot more model rocketry in the hobby business from now on. Part of it is due to the fact that many people and firms are looking around for something to replace slot racing, something to keep their former slot racing factories humming, something to replace the dollar volume of sales they lost when slot racing died in 1967. They think they've found it in model rocketry, but I think they've got to think twice about this. Don't you?

Your mission, should you decide to accept it, is to continue to police the hobby of model rocketry and to keep its safety record good, just as you've always done. This article will self-destruct in five seconds...Four...Three...Two...One...



Another new company has entered the model rocket field. Competition Model Rockets, located in Alexandria, Virginia, is introducing a complete line of kits and supplies designed especially for NAR competition events. Their kits feature built-up, light-weight fins and employ special "pop" launch lugs to decrease the drag of the models. Available for immediate delivery are: The Manta B/G for \$2.75; the Break-Away, a 15 inch long parachute duration rocket priced at \$2.95; and the Hyper, a two-stage, high-performance rocket for altitude and payload events. Also available is an adjustable body-tube cutter at \$1.00. On the drawing boards from Competition Model Rockets are a scale model D-Region Tomahawk kit; a wind tunnel kit; a portable, two-rail professional launch system; and tracking theodolites.

Several new products are reported from Estes Industries. A scale model Mercury-Redstone, the vehicle which carried Alan Shepard on America's first manned space flight, has been introduced in 1:42 scale. The 23½ inch tall rocket weighs 2.1 ounces and flies with an A8-3, B6-4, or C6-5 engine. The detailed kit comes complete with a decal sheet and is priced at \$2.75.

The Orbital Transport, a futuristic design for orbital space travel, is also new from Estes. The transport lifts off under rocket power provided by a B6-4 engine. At ejection the separable reentry vehicle glides back to earth while the booster is recovered by parachute. The Orbital Transport is priced at \$2.50.

The first plastic kit of the Apollo/Saturn V vehicle has been introduced in 1:144 scale (1 inch to 12 feet) by Monogram Models. This model of the Saturn V and Apollo spacecraft is precisely scaled from information supplied by NASA. The model stands 30-3/8 inches high, and comes complete with a display base. All stages separate from each other to demonstrate a simulated flight. A leaflet describing Project Apollo is included in the \$6.00 kit.

The new Centuri 1969 catalog is out, and contains many new products worthy of the attention of all rocketeers. For scale modelers, Centuri has produced an entire 1/100 scale Apollo series -- the Little Joe II, Saturn IB, and Saturn V. The 10.5 inch tall Little Joe II comes complete with a corrugated metalized skin, pre-printed roll patterns, pre-shaped fins, and a molded plastic (continued on page 10)

# Inertias by Torsion Wire

by Gordon K. Mandell

Time-honored experiment needs no wind tunnel, provides unparalleled accuracy in the determination of moments of inertia...

Those readers who have followed our technical series on model rocket dynamics, which concluded last month, are by now doubtless aware that the longitudinal and radial moments of inertia of a model rocket have an important influence on its behavior in flight. Those who read Part IV of that series (*Fundamentals of Dynamic Stability Part IV, Measuring the Dynamic Parameters, in Model Rocketry* February 1969) will also recall the wind tunnel experiments I described by which the moments of inertia, as well as the aerodynamic corrective and damping moment coefficients, could be determined.

Since that installment was written, I have completely reduced the data taken during extensive use of the equipment therein described, and I would be less than honest if I did not flatly state that the experiments were found to be insufficiently accurate in determining the radial moment of inertia. Those experiments provide, in fact, the poorest possible numerical situation for this determination. It will be recalled that the rolling resonance experiment (Experiment 3) provides a measurement of  $(I_L + I_R)$  where  $I_L$  is the longitudinal moment of inertia and  $I_R$  is the radial moment of inertia. The characteristic response measurement (Experiment 2) gives a value of  $I_L$  alone.  $I_R$  is then computed by performing a subtraction:

$$I_R = (I_L + I_R) - I_L$$

Unfortunately,  $I_R$  is on the order of 2 per cent of  $I_L$  for most model rockets. This requires the incredible accuracy of *two tenths of one percent* in the determination of both  $(I_L + I_R)$  and  $I_L$  for us to have any hope at all of getting  $I_R$  accurate to within 10 per cent (the worst acceptable accuracy for model rocket work). This you will never be able to attain, I assure you. I have tried many times, but have never obtained consistent accuracies better than 5 per cent in the value of  $I_L$  or that of  $(I_L + I_R)$ .

Upon searching around for a way to extricate two large, foul-tasting, engineer boots from my mouth, I came immediately upon the torsion-wire experiment. Torsion wires have been used by professional indus-

try for many years and are the standard technique for determining the moments of inertia of such things as the rotors of electric motors and the movements of aircraft instruments. While first working on the problem of devising experiments for model rocket dynamics, I had passed the idea up because it seemed to me, at that time, that the motions of a model rocket on a torsion wire would be too highly damped for the experiment to be practical. Now, upon actually trying it, however, I have found that the experiment works beautifully, providing rapid, precise, and independent determinations of  $I_L$  and  $I_R$ . It's really the perfect experiment for model rocketeers with limited time, funds, and equipment, too— it requires no wind tunnel, its apparatus costs less than fifty cents, can be built in twenty minutes, and the measurement can be made using the actual flying model rocket, so that there is no need to build a special vehicle just for testing.

The heart of the system is the torsion wire itself, a three-foot length of thin music wire. The one I used had a diameter of .018 inch, but for most model rockets, any diameter from .010 to .020 inch, inclusive, will do just as well. You may even wish to use an .010-inch wire for measuring the radial moment of inertia of your model and an .020-inch wire for its longitudinal moment of inertia, as this refinement will reduce the difference in the rapidity of the torsional oscillations which must be observed to determine the respective moments of inertia.

The last inch on each end of the torsion wire is bent over, twisted around, and soldered to the center of a two-inch length of .045-inch music wire, forming a "T" at each end of the wire. These "T" fittings are the means by which the instrument is secured to the test rocket at one end and the mounting structure on the other.

Figures 1 and 2 show the complete torsion wire system set up for measuring the longitudinal and radial moments of inertia, respectively, of a model rocket. The upper "T" fitting is clamped or otherwise secured

to an overhanging beam mount. The beam itself can be a simple two-by-four with its other end clamped to a shelf or any other structure that will allow the suspended rocket to clear the floor of the room in which the experiment is being done (you should do the experiment indoors to avoid stray air currents which might otherwise ruin the accuracy of the determinations). If you wish to build a permanent mounting frame, it will give your setup a more professional appearance; however, I found that the simple two-by-four-and-C-clamp mounting system, besides being easy to build and inexpensive, is readily portable, highly adaptable, and gives the same accuracy.

Also needed to calibrate a newly-built wire system is a reference standard. The standard must be some object having a simple shape and a known, uniform density or mass, so that its moment of inertia can be *computed* from a simple formula. One of the best standards I have found is an aluminum rod one-half inch in diameter and about one foot long, suspended with its long axis parallel to the floor (like the rocket in Figure 1), so that its longitudinal moment of inertia will be effective about the axis of the wire. The rod's moment of inertia  $I_s$  is then:

$$I_s = M \left[ \frac{R^2}{4} + \frac{L^2}{12} \right] \quad \text{gram-cm}^2$$

where  $M$  = mass of rod in grams  
 $R$  = radius of rod in centimeters  
 $L$  = length of rod in centimeters

Now a rod a half inch in diameter has a radius of 0.635 centimeters. If such a rod composed of aluminum alloy No. 6061 is cut to a length of 29.7 centimeters, it will have a mass of 101.8 grams, and thus a moment of inertia of precisely 7500 gram-cm<sup>2</sup>. If you use a rod of different length or diameter, or one composed of different material, you will have to weigh it on a laboratory gram balance or else know the density of the material of which it is composed in order to find its mass and moment of inertia.

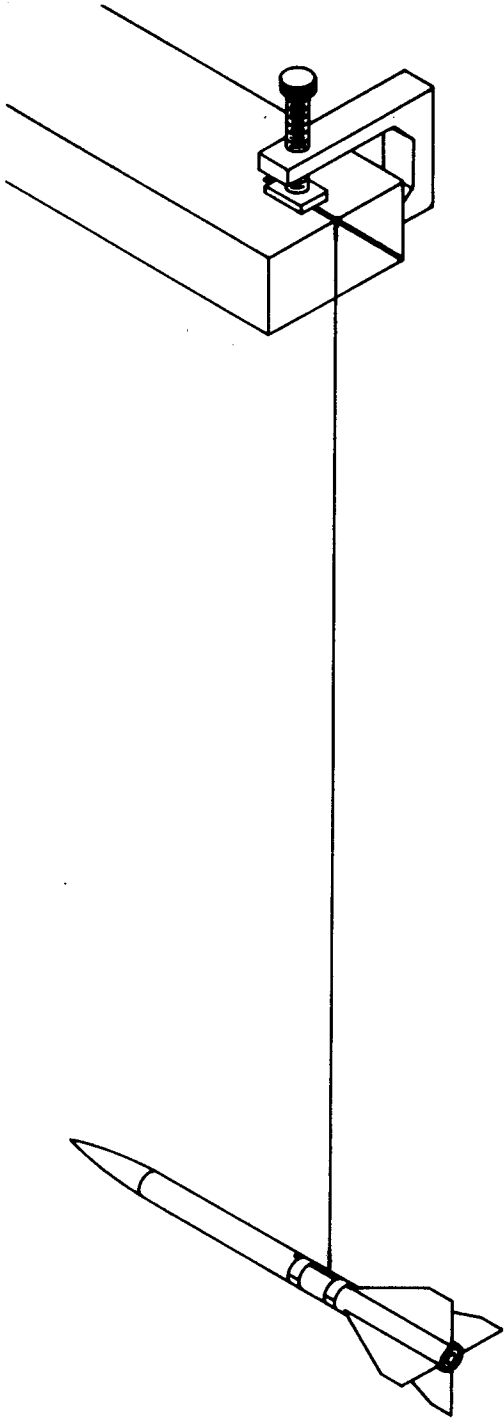

Figure 1. Model rocket suspended on torsion wire in position for measuring its longitudinal moment of inertia.

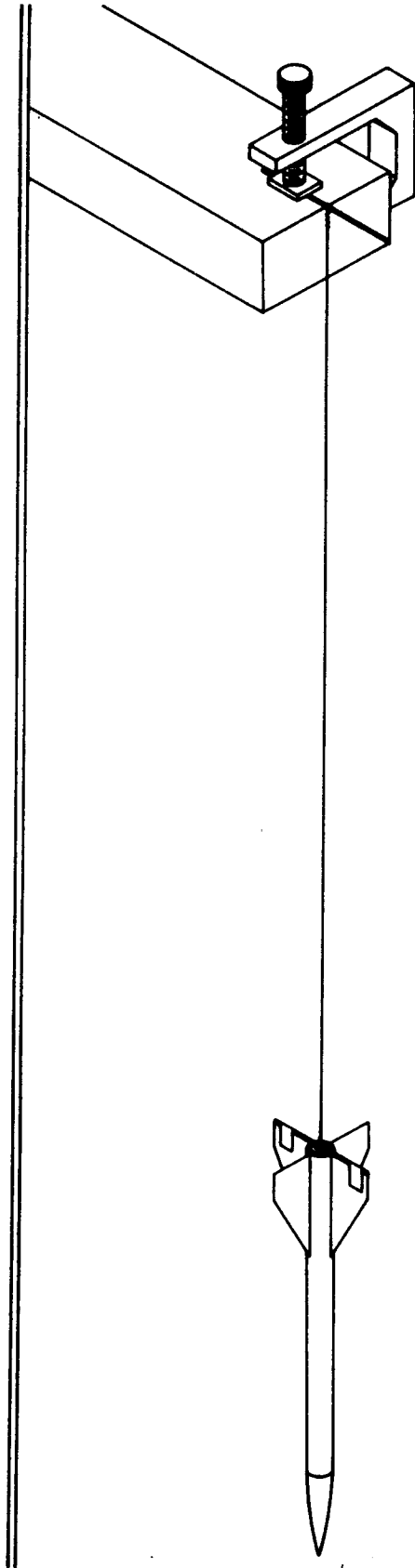
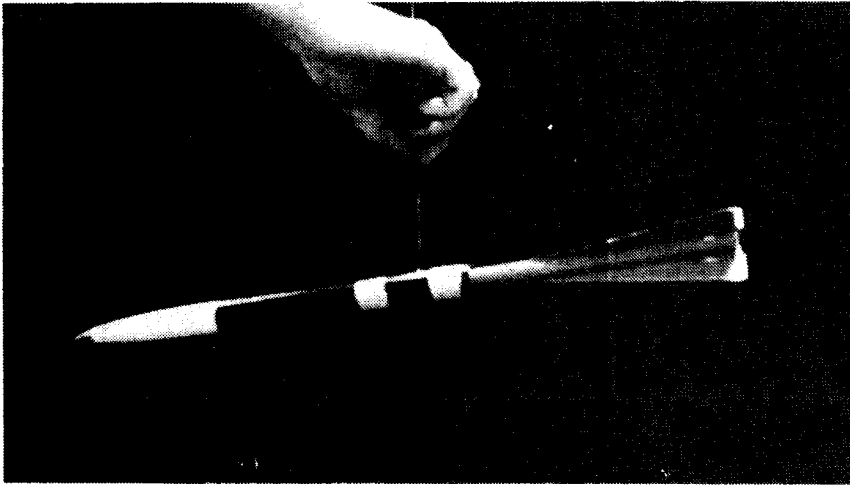

Figure 2. Model rocket suspended on torsion wire in position for measuring its radial moment of inertia.



An actual torsion wire experiment in progress, showing the method of starting the torsional oscillations.

Photo by George Flynn

A timing device completes the experimental apparatus required. While an ordinary wristwatch with a sweep second hand is adequate for this purpose, better accuracy is obtainable from a stopwatch or an electric laboratory stopclock. If a timing device accurate to a hundredth of a second is used, the experiment yields moments of inertia repeatable to better than 2 per cent.

#### Calibrating the Wire

A torsion-wire determination works by measuring the *period of torsional oscillation* of a model rocket suspended from the wire and comparing it with that of the reference standard. The wire must therefore be calibrated by measuring the period of the reference standard before any experiments with actual model rockets are done.

To determine the period of the reference standard, tape it to the torsion wire "T" in a horizontal position, like the rocket in Figure 1. Then twist the wire between your fingers until the reference standard makes nearly one full revolution and release it again, being careful not to start the whole arrangement swinging like a pendulum in the process. The reference standard will begin to turn slowly about the wire axis first in one direction, then the other, twisting the wire this way and that. You have established a torsional oscillation. The *period* of the oscillation is the time in seconds taken for the suspended object to execute one complete *cycle*; that is, to turn from one extreme of the oscillation to the other *and back again*. For purposes of accuracy, you should measure *ten* such periods, starting the timing device when the reference standard is at one extreme of its torsional oscillation and stopping it when the reference standard returns again to that extreme for the tenth time. Divide the time thus measured by ten and you will have a much more accurate determination of the period than you could get by measuring a single cycle. Write down the

period thus measured in seconds, denoting it by  $T_S$ . Save it in your permanent records, for it is your calibration measurement for that particular wire. If you keep permanent records of  $I_S$  and  $T_S$  you need never perform the calibration of that wire again.

#### Performing the Experiment

In order to perform a torsion-wire experiment remove the reference standard from the wire and affix the model as shown in Figure 1 for determining the longitudinal moment of inertia, or as shown in Figure 2 for determining the radial moment of inertia. Start the oscillations and measure the

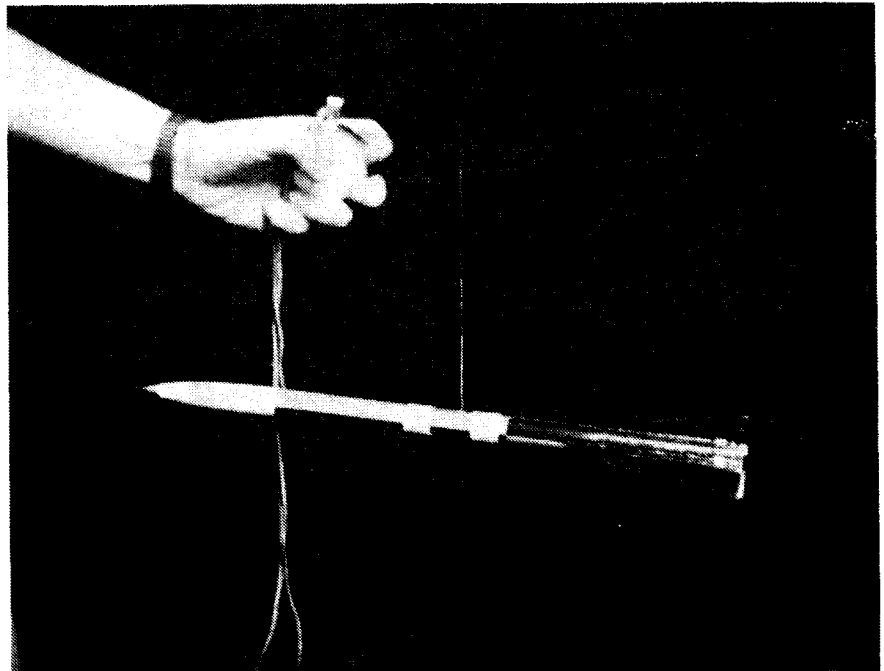

The timer is started when the rocket is stationary at one extreme of its oscillation. The rocket must contain its engine, payload, and all recovery systems components— exactly as it will when it is flown.

Photo by George Flynn

rocket's period in each mounting configuration, just as you did for the reference standard. The diameters of torsion wire I have specified produce relatively slow oscillations which are easy to measure with a high degree of accuracy and which are very lightly damped. It should thus not be difficult to observe the oscillations of both the model and the reference standard for a full ten cycles. Write down the period of the rocket mounted as in Figure 1, calling it  $T_L$ , and the period of the rocket mounted as in Figure 2, calling it  $T_R$ .

#### Reducing the Data

You now know  $T_S$ ,  $T_L$ , and  $T_R$ , which you have measured, and  $I_S$ , which you have computed from its formula. You can therefore determine the longitudinal moment of inertia of the rocket according to the equation:

$$I_L = I_S \left( \frac{T_L}{T_S} \right)^2$$

Similarly, the radial moment of inertia of the model is given by:

$$I_R = I_S \left( \frac{T_R}{T_S} \right)^2$$

That's really all there is to it. These two simple calculations determine the inertial properties of a model rocket quickly, easily, independently, and accurately. Furthermore, you may use these same values of  $I_S$  and  $T_S$  for all subsequent experiments you do with a given wire, once you have calibrated it. Of course, if you measure the longitudinal moment of inertia with one wire and the radial moment of inertia with a thinner wire, you must remember to calibrate *both* wires with the same standard.

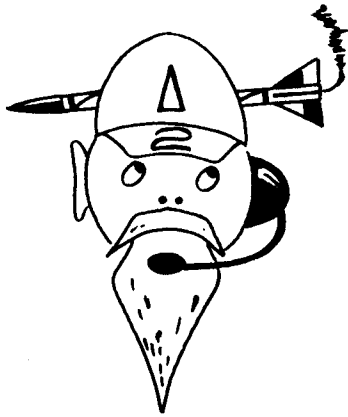

# The Old Rocketeer

by G. Harry Stine NAR#2

Over 6000 ARCAS vehicles have been flown as of 1969.

## Astroscale ARCAS

### History

(NOTE: *Astroscale* is the copyrighted name of highly detailed and thoroughly researched rocket vehicle drawings and data compiled by G. Harry Stine for use by astromodelers, astrohistorians, and other persons interested in rocket vehicles.)

### General Description

The ARCAS Rocketsonde is a single-staged, solid-propellant sounding rocket manufactured by the Atlantic Research Corporation of Alexandria, Virginia. ARCAS is a registered trademark of Atlantic Research Corporation. The ARCAS rocketsonde is available in several "off-the-shelf" versions and is widely used by all three armed services of the Department of Defense and by NASA. There are two major production versions: (a) The "standard" ARCAS whose primary flight mission is the gathering of synoptic wind and temperature data for meteorological purposes to altitudes of 60 kilometers carrying as a payload the ARCASONDE 1A radiosonde which transmits upper atmosphere temperature data to standard AN/GMD-1 or AN/GMD-2 radiosonde

ground receiving stations. Wind data is obtained by radar track of the descending parachute or by the AN/GMD-2 if a transponding sonde is used. The USAF designation of this vehicle is PWN-6A. (b) The ARCAS-Robin whose primary flight mission is to carry the USAF Cambridge Research Laboratories ROBIN payload to 250,000 feet for the purposes of determining winds and atmospheric density. The ROBIN payload is a 1-meter diameter inflatable balloon made of metalized 0.5 mil MYLAR weighing 122.8 grams. This is carried in the ARCAS nose cone and ejected from the ARCAS and inflated at peak altitude, where its subsequent descent is tracked by radar. The USAF designation of this vehicle is PWN-7A. Many other types of payload have been flown - ozonesondes, cameras, water for ice crystal experiments, biological payloads, inflatable shapes for determining air density, and chemical payloads. Basically, the ARCAS is a well-developed, highly reliable, low-cost, general purpose sounding rocket. All North American rocket ranges and many other ranges throughout the world presently have ARCAS vehicle launchers and flight experience.

The ARCAS development program was undertaken by Atlantic Research Corporation in January, 1958, to fulfill the need for an inexpensive rocket vehicle for conducting atmospheric soundings to altitudes of 200,000 feet or more. The ARCAS was specifically designed and developed to provide a reliable, easy-to-use, and inexpensive tool for the meteorologist.

The ARCAS was developed by ARC under the joint sponsorship of the Office of Naval Research, the Air Force Cambridge Research Center, and the U.S. Army Signal Missile Support Agency, with additional support contributed by the U.S. Army Signal Research and Development Laboratories and the U.S. Navy Bureau of Ordnance.

The first ARCAS rockets were flight-tested in November 1958. A fully-qualified system was in field use by August 1959. By December, 1960, over 400 ARCAS vehicles had been flown.

There have been few external changes in the basic ARCAS propulsion system since the original vehicles, but the external shape of the nose has undergone several changes. The original vehicle in 1958 was equipped with a comparatively blunt 1.36-caliber secant ogive. By 1960, this had been re-

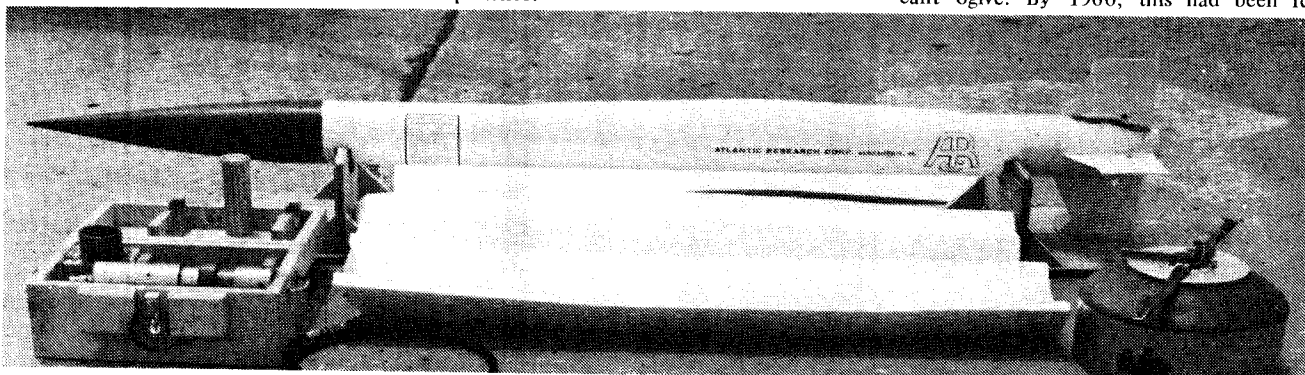

An ARCAS-Robin PWN-7A assembled and ready for installation of igniter (on top of box at left) and launcher piston (on ground at right). Although launched by NASA at Wallops Station in 1962, this ARCAS-Robin PWN-7A is the U.S. Navy version called ARCAS Mk.2 Mod.0. This vehicle is serial number 114543.340 manufactured on August 27, 1961. Modifications were made to the leading edges of the fin tips as shown to change the roll rate because at that time some problems were being encountered in the ARCAS vehicle as a result of roll-yaw coupling and resonance, a dynamic stability problem.

NASA Photo

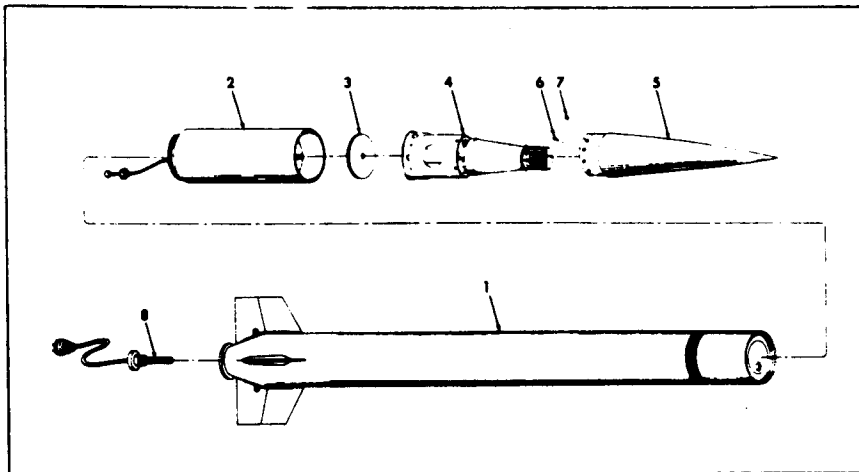

Assembly view of the ARCAS PWN-6A rocketsonde. Key: 1 - MARC 2B2 rocket motor; 2 - parachute cannister; 3 - parachute shock cushion; 4 - ARCASONDE 1A; 5 - ARC No. 5A nose cone; 6 - ARCASONDE mounting screw; 7 - nose cone retention ball; 8 - igniter. (From USAF T.O. 11A11-14-7)

placed with the ARC "Number Five" secant ogive 18.1 inches long with a small ridge around its base. By 1968, the ARC "Number 5A" secant ogive, without the ridge around the base, and fabricated of asbestos-phenolic was in use. Some ARCAS vehicles have been flown with slightly altered fin shapes, but the majority of the vehicles have used the standard production fins.

#### Operation

The ARCAS vehicle in its PWN-6A and PWN-7A versions comes packed in shipping crates and requires two men to remove the components and assemble the vehicle. The basic ARCAS motor is shipped with fins attached and aligned by the factory; the electrical igniter is packed in the same shipping container as the rocket motor, but is not installed in the motor. For the

PWN-6A, the parachute container, ARCASONDE, and ogive are packed separately, and are checked out and assembled just prior to launch. The PWN-7A ARCAS-Robin payload is completely pre-packaged in the nose ogive and needs be merely assembled to the ARCAS rocket motor.

A unique feature of the ARCAS rocketsonde system is the closed-breech launcher that employs the entrapped exhaust gases of the rocket motor to accelerate the vehicle in the launcher by piston action. An aluminum piston is attached to the aft end of the vehicle during travel through the launching tube and separates as the vehicle leaves the tube. The vehicle is supported and positioned in the launching tube during launching by four lightweight foam plastic spacers that are stripped away by aerodynamic forces after the entire assembly leaves the tube at launch.

This closed-breech launcher imparts a

nominal launch velocity of 170 feet per second with an acceleration of 29 g to the PWN-6A. An auxiliary solid-propellant gas generator may be affixed to the launcher and is capable of increasing the launch performance to as much as 260 ft./sec. and 67 g acceleration. This closed-breech launcher permits launching in winds up to 30 m.p.h. and decreases flight dispersion due to weathercocking.

The ARCAS is ignited electrically, is boosted out of its closed breech launcher, and is accelerated by its low-thrust, long-duration end-burning solid propellant rocket motor producing 336 pounds of thrust for 29 seconds. Burnout velocity is approximately 4200 ft./sec. at an altitude of 42,000 feet (with 10-pound payload). At burnout, a pyrotechnic time-delay element in the forward portion of the ARCAS rocket motor is initiated. At approximately 105 seconds after burnout — this time delay may be increased or decreased as desired and programmed into the time delay prior to launch — a separation and ejection gas generator charge is ignited, expelling the payload and parachute — if any — from the vehicle. The parachute is ejected from its cannister in a protective bag which is stripped off, permitting the parachute to deploy. The parachute is a 15-foot diameter hemispherical silk canopy. The ARCASONDE telemeters temperature to the ground and requires over an hour to descend under its parachute to 50,000 feet. No attempt is made to recover the ARCASONDE or parachute.

In the PWN-7A ARCAS-Robin, no parachute is carried. The ejection charge separates the ROBIN payload and ogive from the rocket motor and permits the ROBIN balloon to deploy and fill. No attempt is made to recover the ROBIN.

The empty ARCAS rocket motor casing is permitted to free-fall after separation from its payload and no attempt is made to recover it.

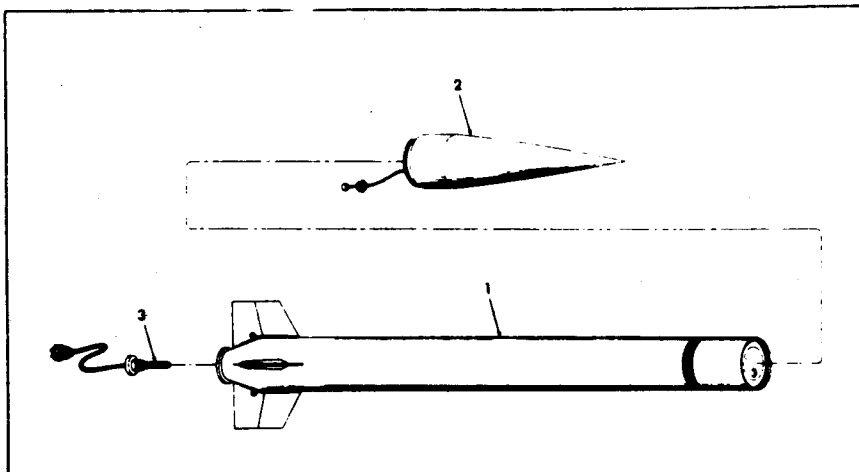

Assembly view of the ARCAS-Robin PWN-7A rocketsonde. Key: 1 - ARC MARC 2B2 rocket motor; 2 - MXU-343/A Ogive with ROBIN payload; 3 - igniter. (From USAF T.O. 11A11-14-7)

#### Weights

ARCAS PWN-6A: Motor and fins, 65.0 lb.; parachute & container, 4.1 lb.; ARCASONDE 1A, 4.5 lb.; nose cone, 2.0 lb.; gross weight at launch, 75.6 lb.; propellant weight, 41.0 lb.; burnout weight, 34.6 lb.

ARCAS-Robin PWN-7A: Motor and fins, 65.0 lb.; ROBIN payload and nose cone, 8.0 lb.; gross weight at launch, 73.0 lb.; propellant weight, 41.0 lb.; burnout weight, 32.0 lb.

#### Performance

ARCAS PWN-6A: (with 10-lb. payload launched from sea-level with gas-generator

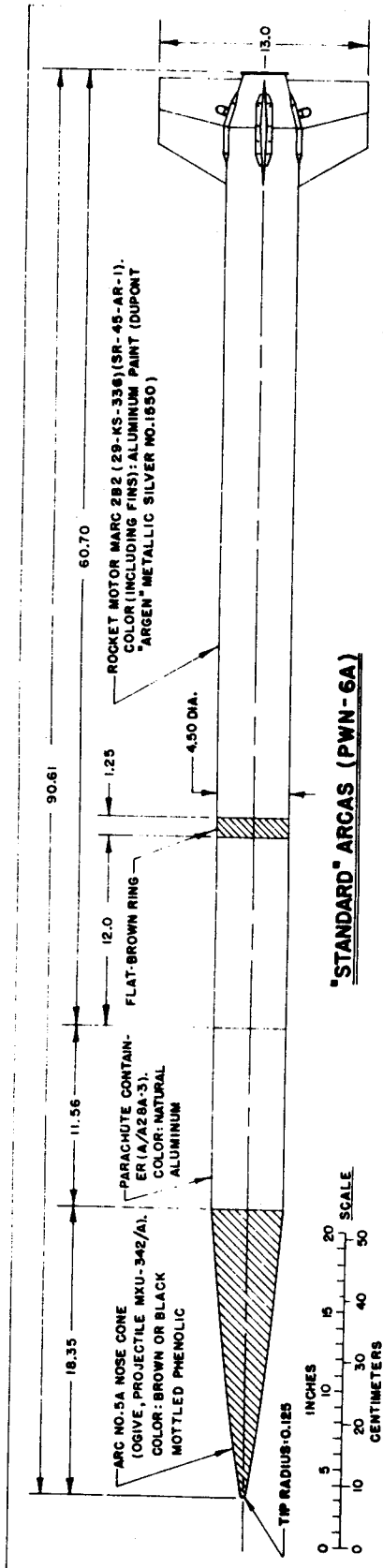

ALL DIMENSIONS IN INCHES

**"STANDARD" ARCAS (PWN-6A)**

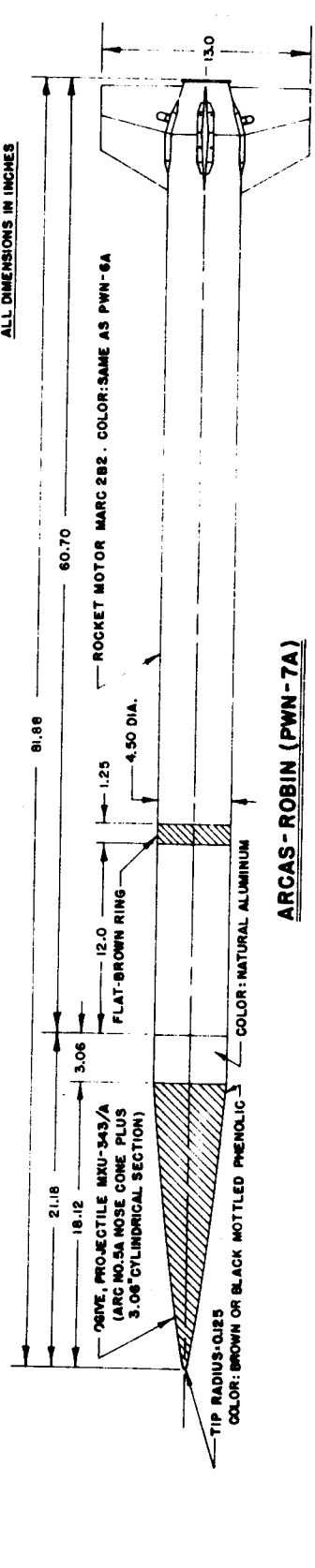

**ARCAS-ROBIN (PWN-7A)**

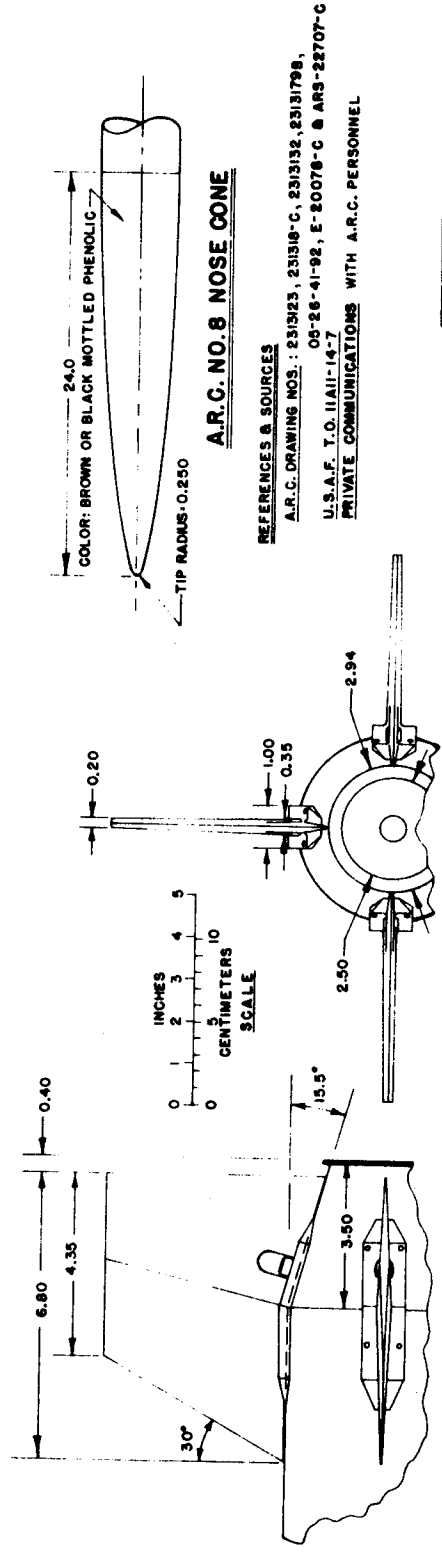

**A.R.C. NO. 8 NOSE CONE**

REFERENCES & SOURCES

A.R.C. DRAWING NOS.: 231923, 231918-C, 231912, 23191798,  
 05-26-41-92, E-20076-C & ARS-22707-C  
 U.S.A.F. T.O. 11A11-14-7  
 PRIVATE COMMUNICATIONS WITH A.R.C. PERSONNEL

REAR PARTIAL VIEW

SIDE PARTIAL VIEW

FIN & BOAT-TAIL DETAILS

**ARCAS**

**ROCKETSONDE**

"ARCAS" IS A REGISTERED TRADEMARK OF ATLANTIC RESEARCH CORP.

DRAWN BY G. HARRY STINE JULY 2, 1968

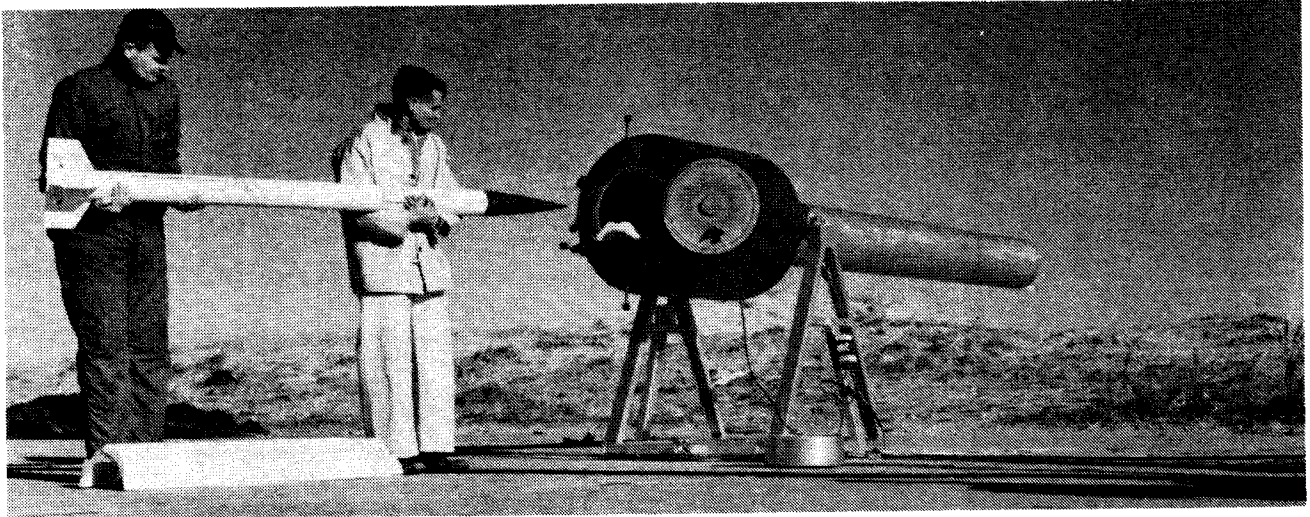

NASA Photo

Technicians load an early ARCAS PWN-6A into the closed breech launcher at NASA Wallops Station in 1960. Note foam plastic spacers for centering vehicle in launcher tube. Vehicle is painted flat white with mottled black phenolic ARC No. 5A nose cone.

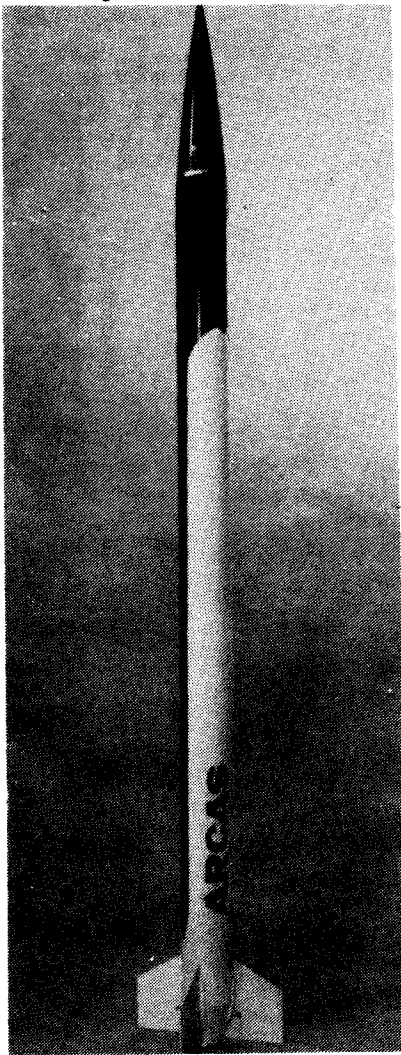

ARC Photo

ARC factory photo of the standard ARCAS PWN-6A painted for company display and advertising purposes with gloss white body and fins and gloss red nose cone, parachute container, and motor trim stripes.

launch boost augmentation and launch angle of 87 degrees) apogee altitude, 224,000 feet; time to maximum altitude, 132 sec.; burnout altitude, 42,000 feet; burnout velocity, 4200 ft./sec.; ground range at apogee, 50,000 feet; nominal spin rate at burnout, 20 rev./sec.

#### Propulsion

Atlantic Research Corporation rocket motor MARC 2B2; (performance data for 70 degrees F.) thrust, 336 lb.; action time, 29 sec.; total impulse, 9089 lb.-sec.; chamber pressure, 1020 psi; nozzle expansion ratio, 13:1; propellant, Arcite 373D composite solid.

#### Color Data

The color data shown on the drawing is the production color scheme in which all ARCAS PWN-6A and PWN-7A vehicles are delivered from the factory. Some ARC MARC 2B2 rocket motor assemblies have stencilled on them forward of the brown ring the data plate shown to the left. Some vehicles have been repainted in the field for optical tracking purposes. ARC often paints its display ARCAS vehicles gloss white with gloss red nose cones and gloss red stripes down opposite sides of the rocket motor.

#### Data Sources

ARC Drawings Number 2313123, 231318-C, 2313132, 2313179B, 05-26-41-92, E-20078-C, and ARS-22707-C.

U.S.A.F. Technical Manuals T.O. 11A11-14-1 and T.O. 11A11-14-7.

ARC Data Sheet 3M-6-67.

"ARCAS, All-purpose Sounding Rocket," by Roland C. Webster, and W.C. Roberts, Jr., Atlantic Research Corp., American Rocket Society Paper No. 1418-60.

Private communications with ARC personnel.

Visit to ARC offices and discussions with ARCAS personnel on June 13, 1968.

#### Note to Modelers:

The ARCAS PWN-7A can be modeled using the Estes Industries, Inc. ARCAS Kit No. K-26, and the scale of this model will be 1:3.396. Since there have been some changes in this kit to conform with newly discovered scale data, the BT-55 body tube should be 17.745 inches long for a scale

<b>ATLANTIC RESEARCH CORP.</b>	
<b>ALEXANDRIA, VIRGINIA</b>	
ROCKET MOTOR	<input type="text"/>
SERIAL NO.	<input type="text"/>
GRAIN NO.	<input type="text"/>
DRAWING NO.	<input type="text"/>
IGNITER DRAWING NO.	<input type="text"/>
STORAGE LIMITS	<input type="text"/>
FIRING LIMITS	<input type="text"/>
DATE LOADED	<input type="text"/>
GROSS WEIGHT	<input type="text"/> LB.
<b>CONFIDENTIAL</b>	
<b>U.S.</b>	

Reproduction of the stencil or decal used on the ARC MARC 2B2 ARCAS rocket motor. Full size is 6"x7" in black.



PWN-7A. To convert the Estes K-26 into an ARCAS PWN-6A, two pieces of BT-55 are required – one for the MARC-2B2 rocket motor and the other for the parachute container – and these should be 16.844 inches and 3.40 inches long respectively. The ridge around the bottom of the Estes BNC-55AC nose cone must be removed to alter it to a current ARC No. 5A nose cone. The small ring around the extreme rear end of the boat-tail does not appear in the Estes kit and can be fabricated from thin strips of Paper Reinforcing, Estes PRM-1, wrapped around the boat-tail to build up the ring. Or the ring can be turned from bar plastic on a lathe such as the Uni-Mat. Note the bolt-holes in each fin; the bolts can be simulated in the model by pieces of 1/8-inch dowel (Estes WD-1). Note also the fin root supports have a rectangular cross-section rather than a rounded one as shown in the kit.

The ARCAS PWN-6A and PWN-7A may appear to be easy scale models to build with very little degree of difficulty. Their apparent simplicity belies the difficulty in achieving a model ARCAS with good appearance. Because of its apparent simplicity, every little flaw in construction, every blotch or run in the paint job, every over-daub of glue, and every little imperfection stands out starkly.

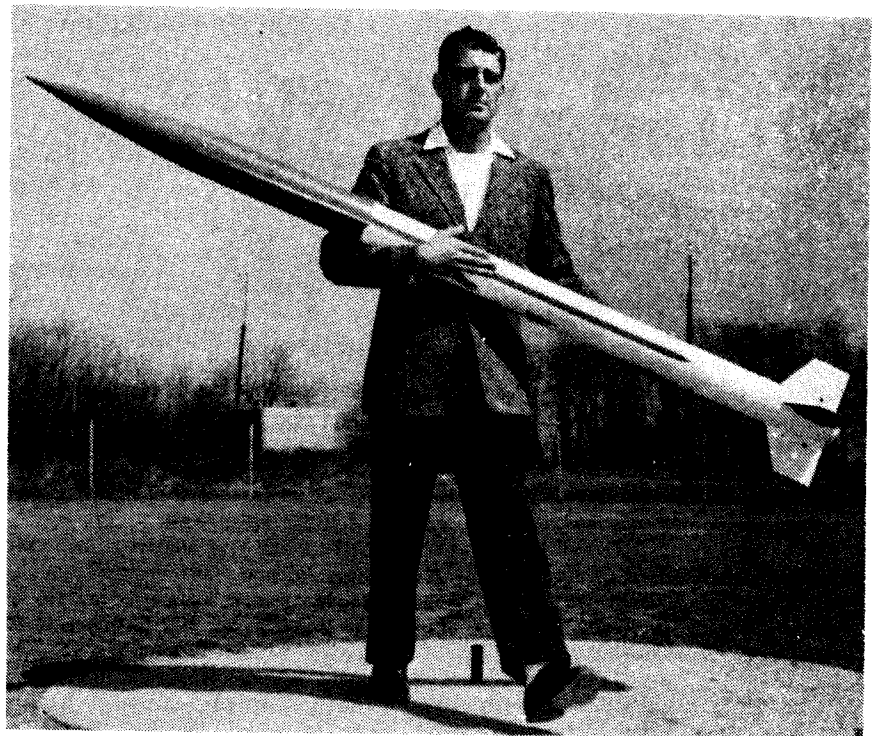

ARC Photo

A standard ARCAS PWN-6A vehicle in the ARC display and advertising color scheme of gloss white body and fins and gloss red nose, parachute container, and motor stripes. Sometimes body stripes go aft in line with fins, sometimes between fins.



Gordon Wood, Atlantic Research Engineer, (left) points out scale details on ARCAS PWN-7A models built by Ellie Stine (center) and U.S. Junior National Champion Connie Stine (right) as they compared their models against the real thing at Atlantic Research Corporation following NARAM-10.



Photos by Stine

Ellie Stine, NAR No. 1955, loads her scale ARCAS-Robin PWN-7A on the launch rod at NARAM-10, NASA Wallops Station.

# Technical Notes

George Caporaso

In response to many letters to this column, this month I will discuss the extension of the altitude approximations (Model Rocketry October 1968) to the case of multistaged rockets. The detailed derivation of the extensions is given in the accompanying box.

To calculate multistaged performance, one still uses the basic differential equation of motion shown in the figure. The only things that have been changed from the single-staged case are the various *limits of integration*.

To better conceptualize the reason for the limits shown, consider the second stage at the instant it separates from the booster. The initial momentum at that point is just the second stage mass times the burnout velocity of the first stage. We must integrate its final momentum which is the second stage burnout mass times the second stage burnout velocity.

The thrust acting on the second stage is integrated from zero to the second stage burning time to calculate the impulse added to the second stage. In addition, the weight of the second stage is integrated over the

second stage burning time to find its negative contribution to the momentum.

The drag is integrated over the second stage burning time also, but it is *integrated from the initial, non-zero drag of the second stage to the final drag of the second stage*. With the approximations previously discussed in the October 1968 article (*Model Rocket Altitude Calculations*), the approximate drag integral becomes  $kxv$  (as defined in the box) which must be taken from the burnout altitude and velocity of the first stage times the second stage drag  $k$  to the final altitude achieved by the second stage multiplied by the second stage burnout velocity and the second stage drag  $k$ .

The accompanying graph will perhaps shed some light on the reasons for choosing the drag limits.

The generalization for three or more stages now becomes clear from the second stage formulae; just replace the first stage burnout altitude and velocity by their second stage values in order to calculate the third stage performance.

(1)  $\frac{dp}{dt} = P(t) - m(t)g - kv^2$        $p = \text{momentum, } P(t) = \text{thrust}$   
 $m(t) = \text{mass, } k = \text{drag constant}$

(2)  $\int_{t_1}^{t_2} \frac{dp}{dt} dt = \int_{t_1}^{t_2} P_2 dt - \int_{t_1}^{t_2} m_2 g dt - \int_{t_1}^{t_2} k_2 v^2 dt$

(3)  $\int_{t_1}^{t_2} k_2 v^2 dt = k_2 xv \Big|_{x_1, v_1}^{x_2, v_2} - \int_{x_1, v_1}^{x_2, v_2} xadt(k_2)$

(4)  $\int_{t_1}^{t_2} k_2 v^2 dt = k_2 xv \Big|_{x_1, v_1}^{(x_2 + K), v_2}$

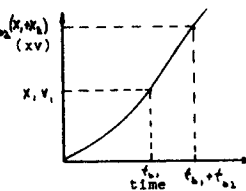

$k_2 = \text{second stage drag constant}$   
 $P_2 = \text{second stage thrust}$        $t_{b2} = \text{second stage burning time}$   
 $m_2 = \text{second stage mass}$        $x_2 = \text{altitude gained by 2nd stage}$   
 $v_{b2} = \text{2nd stage burnout velocity}$        $v_{b1} = \text{1st stage burnout velocity}$

Putting (4) into (2) yields

$$v_{b2} = \frac{m_2 v_{b1} + k_2 x_1 v_{b1} + t_{b2} (P_2 - m_2 g)}{m_2 + k_2 x_1 + k_2 x_2} \quad (5) \quad \text{and}$$

$$x_2 = \frac{-(m_2 + k_2 x_1) + \sqrt{(m_2 + k_2 x_1)^2 + 2k_2 t_{b2} [(m_2 v_{b1} + k_2 x_1 v_{b1}) + t_{b2} (P_2 - m_2 g)]}}{k_2} \quad (6)$$

Back issues of Model Rocketry are available at 35 cents (plus 15 cents postage) each while the supply lasts. Feature articles include:

## October 1968

Dragstab: A finless rocket .....  
 Wallops Station..... Model Rocket  
 Altitude Calculations... Apex I:  
 A high altitude rocket.....  
 Egglifter II..... Fundamentals of  
 Dynamic Stability, Part I.....  
 Bomarc B Scale Design .....

## November 1968

Model Rocket Recovery by Extensible Flexwing..... High Quality Aerial Photography, Part 1..... Calculating Drag Coefficients..... Scale: MT-135..... Project Apollo..... XR-5C: Three Stage Cluster Rocket Design..... Fundamentals of Dynamic Stability, Part 2..... The Versitex: A payload rocket .....

## January 1969

The Stygion: A Rocket with Card-board Fins..... Designing a Club Launch Panel..... Using Super Monokote..... High Quality Aerial Photography, Part 2..... Scale Design: Viking IV..... Fundamentals of Dynamic Stability, Part 3..... Sounding Rockets..... A Minimum Resistance Launch Panel..... Avenger II: Two Stage F-engine Altitude Rocket.... A Problem in Stability .....

## February 1969

Zeta Single Stage Sport Rocket Plans..... The Flight of Apollo 8..... Fundamentals of Dynamic Stability, Part 4..... Non-Vertical Trajectory Analysis..... The Old Rocketeer..... Cosmic Avenger: Construction for Class E Engines..... Scale Design: Nike-Deacon..... Model Rocketry for the Depraved..... World Championship Scheduling Report .....

Send your back issue orders to:

Back Issues  
 Model Rocketry  
 Box 214  
 Boston, Ma. 02123

# The Wayward Wind

by Gordon Mandell

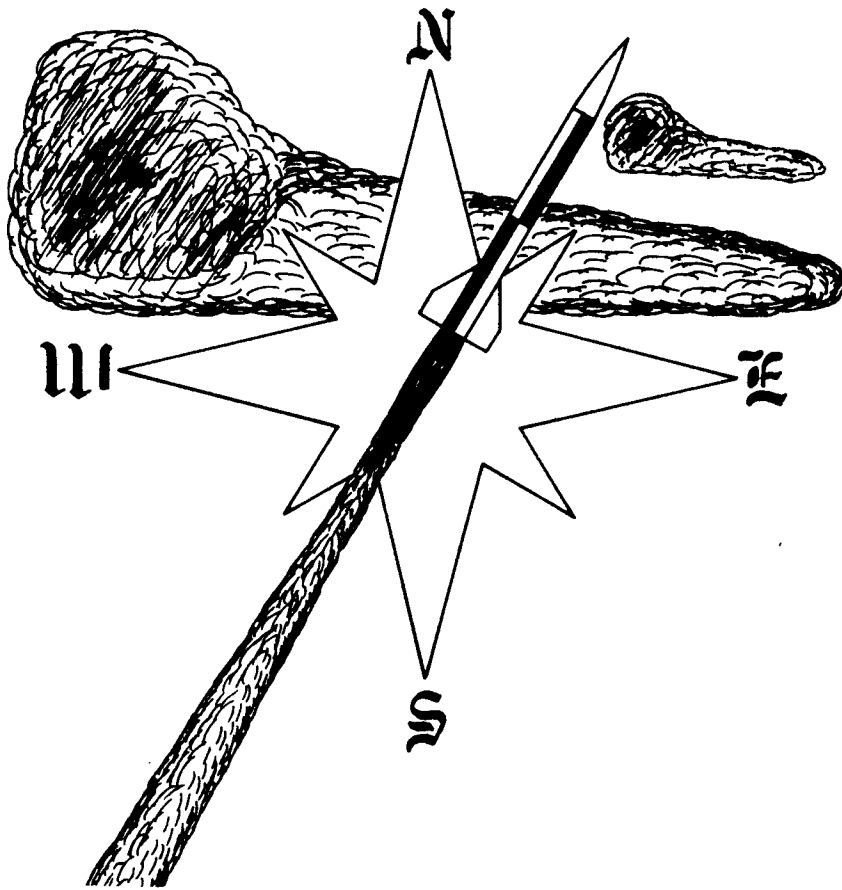

This month begins what is to become my regular column in *Model Rocketry*. As the name suggests, I intend to wander over a wide range of topics in the course of writing it, treating matters of technology, competition, design, and construction, people, places, and events.

In particular, I'm going to try to give you a view of these topics as they appear in historical perspective. I feel that there is a great need for this kind of treatment in our hobby, since our chronic turnover problem results in our being confronted with an almost totally new group of model rocketeers every two to three years. The basic reason for this (as we've editorialized) is that the hobby has offered insufficient challenge—there just haven't been enough advanced topics and projects to keep juniors interested in the sport as they grow up. This problems, of course, is what we at *Model Rocketry* are trying to alleviate with our technical articles.

As a corollary to this major difficulty, communications within model rocketry have been poor and sporadic. They lack continuity. An idea is born and starts to spread, but before it gets very far from its source, the communications network along which it is travelling shrivels up and dies. Result: a dormant idea. Five years later, along comes somebody else who wastes a lot of time and effort duplicating the first guy's work and wonders "why nobody ever thought of this before"—and then the

whole thing happens all over again. By presenting topics in their historical context and providing this missing continuity, I hope to be able to bridge the "generation gap" that today plagues our hobby and prevents the free flow of ideas that we must have for our healthy growth.

You, the model rocketeers of today, can help me in this task by sending me any idea you have ever had about anything. I will tell you whether or not it's new to me and, if not, use these pages to write down as much of its complete history as I know. I date back to 1959 as a model rocketeer, and back to 1961 as a member of the NAR, so my recollections should be fairly complete—but where there are gaps, I won't hesitate to tap the memories of real alte Kaempfer like Harry Stine to complete the record.

This month's topic:

## Bring Back Those Towers!

Just this last month, we received a photo in the mail from the ARC-Polaris Rocket Club in New Mexico, which showed a large model rocket taking off from a tower. It's

been so long since I've seen a launching tower in use that the picture started me thinking..... whatever happened to towers, anyway? They seem to have virtually disappeared as a means of launching model rockets. The towers—and all other means of launch guidance—appear to have been totally displaced by the ubiquitous launching rod. Why?

In the case of the tower, I think, it must have been a combination of economic factors, handling considerations, and technological trends. Although the earliest model rockets of the 1956-1957 period were rod-launched, towers made their appearance early in our history, too. The first tower designed specifically for launching model rockets was a scale Pogo-Hi launcher constructed of wooden rails and brazed steel rod, designed by G. Harry Stine of (at that time) White Sands Proving Ground in New Mexico. About three feet high, the Pogo tower could take any three-quarter-inch rocket and appeared with an Aerobee-Hi model in the 1957 *Popular Mechanics* articles through which the American public was first introduced to model rocketry.

Model Missiles, Incorporated—the first model rocket manufacturing firm—got into the tower business early with their 42-inch-high, steel-angle tower. This launcher was available either in kit form or pre-assembled and could be built to fit either three-quarter-inch or one-inch rockets. From the time it first became available in 1958, the

MMI tower became a standard item in model rocketry. I got mine late in 1959 at its then-current kit price of \$9.95 (I still have it) and, at the time I joined the NAR late in 1961, the standard section multiposition launch rack contained two of these things, one on either end, with four rods in the middle.

Shortly thereafter, though, MMI closed up shop (the last time I remember seeing MMI at a manufacturer's demonstration was NARAM-4 in August of 1962). The remaining stock of MMI towers was sold to Estes Industries, production was discontinued, and the last MMI tower was sold off some time during the winter of 1962-1963. It was the end of an era in launcher design. With the demise of the MMI tower, independent tower designs also became few and infrequent. The towers in use, for the most part, fell into disrepair and were left in the basements of former section range officers who have long since departed from the hobby. Some were handed down from section administration to section administration, and some (like mine) are still owned by individuals—but by and large, their use has become so infrequent that it is cause for comment when one of them shows up on a rocket range.

Not that MMI's people were the only ones who did anything in the way of tower design. The early years of model rocketry were also years of great creativity in launcher design on the part of clubs and individuals. The Peak City NAR Section of Colorado Springs, notably, built a number of launch towers having adjustable guide rail spacing to enable the launching of rockets of various diameters around 1958. Some difficulty was experienced with these in the form of "play" in the adjustable rails, but in all they served admirably and were still in service at the 1962 Nationals. I don't know what has happened to them since, but presumably someone out there still has



them.

The big Coaster engines (ancestors of today's Centuri Mini-Max series) were just beginning to receive NAR certification at this time, and some big towers to fly these birds from were in the works. I know the history of at least one of these things, which I built during the winter of 1961-1962, at a cost of about \$75.00. This was the launcher for the Pegasus sounding system, a ten-foot-high, all-aluminum tower with four guide rails containing a rocket three and one-eighth inches in diameter. Unfortunately, the Pegasus rocket was over the weight limit and never flown. Although modifications to the Pegasus tower which would allow the launching of smaller-diameter rockets were planned, they were never carried out, and to this day the Pegasus launcher resides, in brand-new condition, in my basement.

The most magnificent model rocket launcher I ever saw was the work of the team of Len Fehskens and Hank Isaacs of the Fairchester NAR Section on the Connecticut-New York border. In 1964, these two built an exact scale model, in wood, of the Aerobee-Hi launching tower at White Sands. Standing 16.5 feet high, the tower served as the scale launcher for the two-staged, Prodyne-powered Aerobee in what was then called the USAF Aerospace Systems Competition. The Aerobee tower came to grief at NARAM-6 while on display at NASA's Wallops Station, when a gust of wind pulled up the stakes used to hold it in place, and brought it crashing down. The last I heard, Len and Hank were still paying warehouse fees for the storage of the damaged tower.

That was about the end of the line for tower development. From then until we received the ARC-Polaris photo, I never saw another one built. As I said, I think economics had something to do with it. The decision of the major manufacturers to discontinue towers must have been based on a conviction that they wouldn't sell because they were much more expensive than a rod which served the same purpose. They were also heavier, more difficult to transport, erect, and load, and needed more skill to construct. Ergo, they were a bad investment.

In the case of the larger towers, the handling and transportation problem was indeed acute. If you didn't have a big station wagon, forget it...and setting one up with a rocket inside was a two-man job, at least.

But most of all, I think, it was the trend of our technology that killed the towers. In 1962, model rocketry was just starting to discover lightweight components and the boost-glider was coming into its own as a competition vehicle. The rocketeers proceeded to go hog-wild for lightweight construction, taking out every last bit of weight, caring nothing about drag, and winding up with tail-heavy birds needing

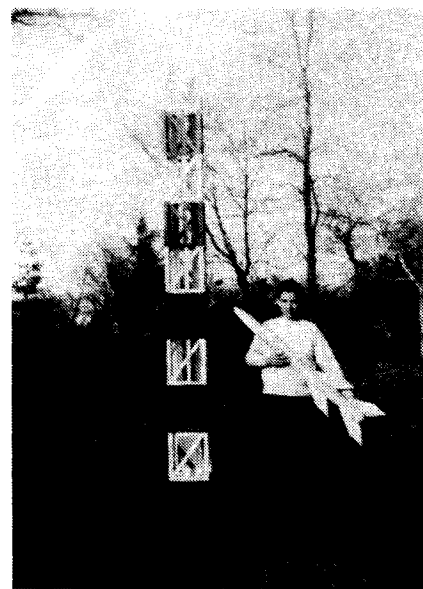

huge fins that half the time wouldn't fit in a tower. Since they cared nothing about drag, they cared nothing about care in structure or finishing, so the other half of the time, the rockets were such garbage that they weren't *straight* enough to go into a tower. And, of course, boost gliders by their very nature, could not be flown from a tower. And the launch lug needed for rod flight? Well, rumor had it even then that the launch lug might increase drag quite a bit—but, then, quite a bit of something that didn't seem to matter much was...something that didn't seem to matter much, so the rods swept the field and won the day.

In 1966, though, the technological pendulum began to swing back in favor of more balanced design. Jim Barrowman showed that we could get by with smaller fins than had previously been thought possible. Between 1966 and 1968, Len Fehskens, Doug Malewicki, and George Caporaso showed that drag has a *dominant* influence on the altitude capabilities of model rockets, and that there is an optimum weight for a model that is *not* the lightest weight to which it can be built.

This being the case, it would seem that towers—or at least some form of launchers eliminating the need for a launch lug, have their place in model rocketry after all. Rods and rails, because of their convenience, light weight, and low cost, will certainly remain standard for sport flying and boost-glide competition. But lugless launchers, I think, will be coming back into use in all forms of altitude and payload-altitude competition. So take heart, *ye alte Kaempfer*—dust off that old tower. The end is not yet! And those of you who have more recently joined our ranks—get out that drawing board. The variety of tower designs possible, especially with the new rail sections available through Estes, is virtually infinite. Lugless launch, far from being a ghost of the past, is the Way of the Future.

# Reader Design Page

Each month Model Rocketry will award a \$5.00 prize for the best original rocket design submitted by a reader during the preceeding month. To be eligible for this prize, entries must be suitable for offset reproduction. They should be carefully drawn in black ink on a single sheet of 8½ by 11 paper. Sufficient information should be contained in the drawing so that the rocket can be constructed without any additional information.

Submit entries to:  
 Rocket Design  
 Model Rocketry  
 Box 214  
 Boston, Mass., 02123

This month's rocket is a 2-engine cluster design for lifting payloads. Richard Watson of Salem, New Jersey, submitted this design.

The rocket employs an Estes BT-50, with part of the lower side cut away. The engines fit in BT-20 tubes, and these are protected on the outside by a dummy engine casing cut in two halves.

The type of payload is optional, but Rick suggests using some sort of payload because of the heavy tail end.

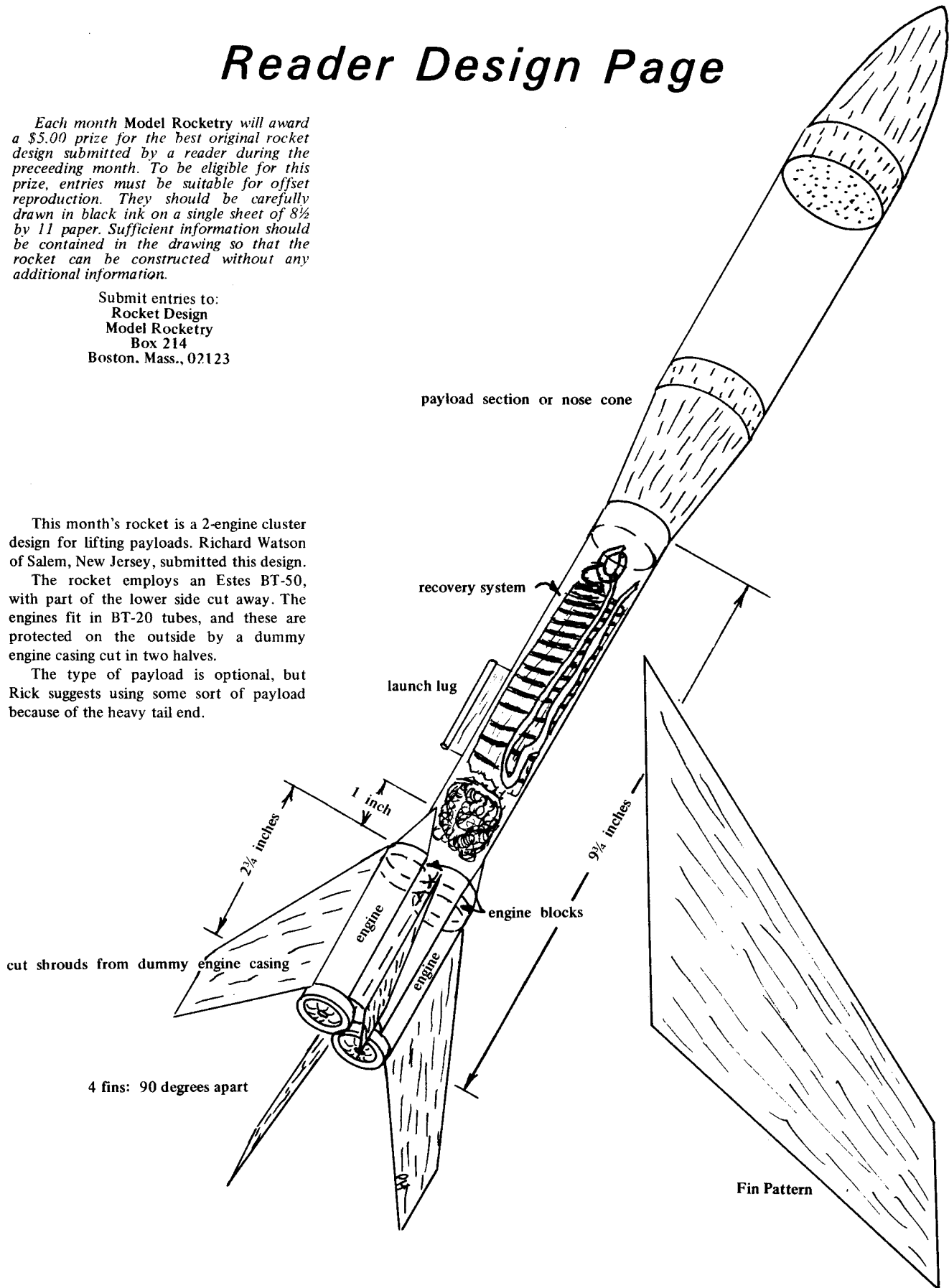

# Fundamentals of Dynamic Stability: Corrections to Symbols and Equations

Last month *Model Rocketry* concluded its five-part series on the dynamic stability of model rockets a serialized treatment in which the rotational dynamics of slender projectiles subject to aerodynamic forces was investigated from the standpoint of basic mathematical physics, with a view to improving model rocket design. This treatment necessarily included a large number of mathematical symbols and formulae which could not be typeset and required hand-insertion, for which various techniques were tried. In the process, an unfortunate number of printing errors and omissions occurred.

In order to minimize the inconvenience caused to our readers by these errors, *Model Rocketry* is presenting a complete list of corrections. The list is organized by Part (month), page, column, and line.

## Part I (October, 1968)

Page 22, column 1, lines 58 and 59 should read:

...dyne-cm-sec<sup>2</sup>, or the equivalent form of gram-cm<sup>2</sup>. Provided that the rocket...

Page 23, column 1, footnote should read:

\*Radians, being physically dimensionless, do not appear in the units of either  $C_1$  or  $C_2$ .  $C_1$  is thus given in dyne-cm rather than dyne-cm/rad,  $C_2$  in dyne-cm-sec rather than dyne-cm-sec/rad.

Page 23, column 3, line 5 should read:

...A, D,  $\omega$  and  $\phi$  are constants. A is...

Page 24, column 2, line 9 should read:

...occurs when  $\zeta$  reaches  $\sqrt{2}/2$ , or about...

Page 25, column 1, lines 2 and 3 should read:

... $\omega$  is just  $.707\omega_n$ . As  $\zeta$  approaches 1.0,  $\omega$  approaches zero and when a unity...

Page 25, caption to Figure 11, should read:

A step disturbance of value  $M_s$ . The yawing moment is zero before the origin,  $M_s$  after it.

Page 25, caption to Figure 12 should read:

Undamped step-response, showing the coordinates of the first peak. The rocket oscillates indefinitely about the value  $M_s/C_1$ .

Page 25, caption to Figure 13 should read:

Underdamped step-response, illustrating the coordinates of the first peak. A yaw angle of  $M_s / C_1$  is approached as time increases.

Page 26, column 3, line 12 should read:

...proach the terminal value of  $M_s / C_1$  is...

Page 28, caption for Figure 21 should read:

The variation of amplitude ratio with frequency ratio for rockets having various damping ratios, showing the resonant behavior of those whose damping ratios are less than  $\sqrt{2}/2$ . For damping ratios greater than this value no resonance occurs.

Page 28, column 3, line 12 should read:

... $I_L$ . Adequate values of  $C_1$  and  $I_L$ ...

Page 29, column 2, line 35 should read:

...AR<sub>RES</sub> can be dangerously high. A tiny...

Page 29, column 3, lines 15 through 24 should read:

For all values of  $\zeta$  the phase angle  $\phi$  is seen to decrease from zero toward  $-\pi$  radians as  $\beta$  increases from zero toward infinity, passing through  $-\pi/2$  at  $\beta=1$ . The "sharpness" of the transition increases as the damping decreases, becoming a step at  $\zeta=0$ . Because  $\phi$  is always negative for nonzero values of frequency the response is said to "lag" the disturbance.

## Part II (November, 1968)

Page 26, column 2, line 27 should read:  
...first and second modes, and  $\phi$  and...

## Part III (January, 1969)

Page 30, column 3, lines 23 through 29 should read:

$M_f$ =mass of fin  
 $A$ =lateral area of one side of fin  
 $R_r$ =radius of fin root from centerline of rocket  
 $R_t$ = radius of fin tip from centerline of rocket  
 $a$  = root chord of fin  
 $b$  = tip chord of fin

## Part IV (February, 1969)

There are no errors in mathematical symbols

## Part V (March, 1969)

There are no errors in mathematical symbols



**NEW...**

**MODEL ROCKET KITS  
AND  
ACCESSORIES**

**OTHER KITS AVAILABLE:**

- ASTRO-QUEST
- ALPHA-1
- ALPHA-B
- SWIFT
- SPARTAN
- AJAX

**KIT PRICES RANGE FROM**  
\$1.50 - \$2.00

**ALL KITS FEATURE:**

- HARDWOOD NOSECONES
- EASY TO FOLLOW INSTRUCTIONS
- PROVEN & TESTED DESIGNS
- NEW & DIFFERENT

**ALSO AVAILABLE:**

- PLASTIC NOSECONES PLAIN & CHROME-PLATED

**DEALERS' INQUIRIES WELCOMED**  
WRITE FOR MORE INFORMATION TO.....



**PHOENIX**

- EASY TO BUILD
- 21 INCHES LONG
- HIGH PERFORMANCE

**\$ 2 00**



**BO-MAR**  
DEVELOPMENT COMPANY, INC.  
534 KENWICK DRIVE, SYRACUSE, NEW YORK 13208

# Relativistic Model Rocketry

by George Caporaso

## The Ideas of Einstein Form a Unified Model Rocket Theory

In recent years, the appearance of highly efficient, high-total impulse engines on the model rocket market has led to flights whose trajectories have shown significant deviations from the equations of Malewicky and Caporaso. In vain attempts to remedy the situation, various researchers have sought variable mass corrections for the altitude equations<sup>1</sup>. The author, however, strongly believes that the observed discrepancies in flight performance are merely the manifestations of special and general relativistic effects on the rocket, and will derive equations of motion for model rockets which are Lorentz covariant with respect to different reference frames.

### CASE I: Special Relativistic Effects

In the high velocity regime, many special relativistic effects will be noticed. The first, and most notable, is the relativistic increase in mass of the rocket with respect to an observer on the "fixed earth." Of course, increased mass will mean an increase in the rocket's weight, and, consequently, in the weight of the propellant. The increased propellant weight exiting from the nozzle increases the thrust in proportion (assuming exhaust velocity is small). Thus, the thrust to weight ratio is an invariant quantity.

There is no gain in total impulse, however, as the time in the rocket's reference frame is reduced by the same factor as the fuel mass is increased so that the product, the total impulse is also an invariant. However, the specific impulse, or total impulse per pound of propellant, is a covariant quantity (i.e., it is different in different reference frames and decreases from its static test value as the vehicle's speed with respect to the earth increases).

Of course, the time dilation effect can account for much of the anxiety felt on the part of unwary modelers who have sent threatening letters to the manufacturers of high thrust engines asserting that they have received engines with shorter burning times than they ordered.

The effect also persists in the coasting phase where it can be particularly disastrous. Since the rate of time in the rocket is slower than that of a "fixed" earth frame, the time delay observed on the ground is somewhat longer than that listed on the engine. Many is the poor rocketeer who has torn his Malewicky report to shreds after seeing the ejection charge of his engine ignite after his high performance rocket has

made a spectacular but ruinous impact into the earth.

Another effect, which is particularly annoying to trackers, is the Lorentz contraction of the rocket. The length of the rocket will decrease in the direction of its motion while its diameter and other dimensions remain invariant. As the model rocket's velocity approaches that of light, the length shrinks to zero, the vehicle becomes two dimensional and the space time continuum shrinks to a singularity at that point. This is a rather desirable effect from the point of view of reducing friction drag, but it renders tracking somewhat difficult.

Of course, one must be careful that his rocket remains statically and dynamically stable because, as the length shrinks, so does the longitudinal moment of inertia and various aerodynamic coefficients, but not the radial moment of inertia. The pressure drag coefficient will also change adversely, as the shape of the model assumes a more blunt appearance.

As a final word on special relativistic effects, it should be noted by the reader that within the framework of known physical science, it is impossible for a material body to achieve or exceed the speed of light. And the reader should be cautioned that the assertions of a certain Mr. Davis, with regard to his 73 F engine, 5 stage cluster breaking the light barrier, are completely groundless and that no further heed should be given the said "researcher's" wild exhortations.

### CASE II: General Relativistic Effects

We now proceed to the consideration of general relativistic effects. It should be noted at this stage that while the great body of the special theory of relativity is accepted by modern physicists, the General Theory is not so well established, and has been criticized by such eminent physicists as Professor Dicke of Princeton, who has proposed an alternate "tensor-scalar" theory<sup>2</sup>. However, the effects to be explained are treated in basically the same manner by both theories.

Before discussing possible general relativistic influences on model rockets, it is advisable to present some basic concepts of the theory. Following the precedent set by the eminent Professor Stine, "I will not go basic on you." Now, let us proceed.

### Force

Einstein rejected the notion of force, or "action at a distance." Instead, he sought to unify the various interactions in nature (gravitational, electromagnetic, nuclear forces) through geometry. He assumed that the presence of a mass or charge *warped* space around the object and that any body in the presence of that mass or charge interacted with it through the warps of space.

And space itself does not obey Euclidean geometry, that is, the geometry of straight lines and planes. Instead, space obeys a curved geometry; either the "positive" curvature of spherical geometry, or the

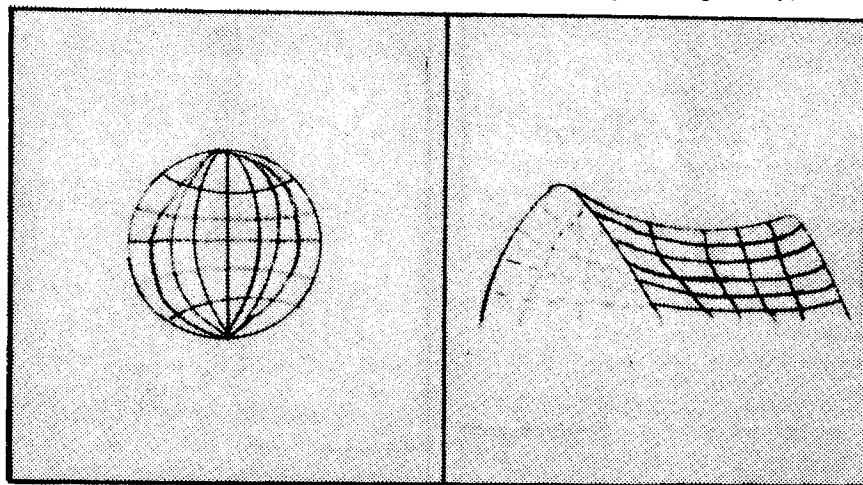

Fig. 1. "Positive" curvature of spherical geometry (left). "Negative" curvature—hyperbolic paraboloid of Bolyai and Lobachevski.

“negative” curvature of Bolyai and Lobachevski. These geometries can be represented by their *metrics*, two of which are illustrated as a sphere and as a hyperbolic-paraboloid in the accompanying figure. The actual metric of space is a four dimensional one consisting of the conventional 3 dimensions and time as the fourth one. It is customarily specified mathematically by its *metric tensor*.

Armed with this knowledge, we are now in a position to understand why some engines exhibit less thrust than claimed by the theoreticians. And, we are also able to clear up the “Krushnic Effect” once and for all.

Drawn in figure 2 is the nozzle end of a rocket showing the *equipotential* lines of constant gravitational potential with respect to the engine. These are lines indicating that in order to move some rocket exhaust goes from the nozzle to any point on an equipotential line. Also, the farther out from the nozzle the exhaust goes, the greater the potential energy it has. Since the exhaust seeks the point of lowest potential as does any physical system, the exhaust is impeded from moving from the nozzle and tends to diverge outward along the equipotential lines. All this results from the fact that the nozzle end of the engine warps the metric of the space-time continuum.

The “Krushnic Effect” can be explained using the same basic principle. For the benefit of those readers not familiar with this effect, a brief explanation will be given. If an engine is recessed in a tight-fitting

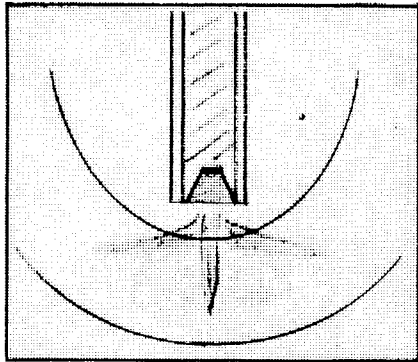

Fig. 2. Illustration showing warped space, equipotential lines and resulting exhaust divergence.

body tube more than about 1/4”, the thrust becomes so small as to be non-measurable. This effect has been erroneously ascribed to nearly everything from ultrasonic waves in the tube to overexpansion of the exhaust and constitutes a perfect example of how intelligent, scientifically trained people can occasionally go overboard on the explanation to a simple, straight-forward problem. The answer to the “Krushnic Effect” should now be obvious to the reader as it follows trivially from the aforementioned relativistic principles.

Figure 3 reveals in fabulous, graphic

detail the true cause of the “Krushnic Effect” and delineates the warped metric of the space-time continuum just aft of the rocket. The unoccupied, extremely dense body tube contributes a non-zero, antisymmetric component to the metric tensor describing the local region of space and bends the equipotential lines (in three dimensions they are surfaces) in the manner shown ever further than in the previous case of a massive nozzle.

The exhaust tends to follow the equipotential lines and directs momentum from the main stream of the gas, thus greatly decreasing the thrust.

There are many other effects that can be explained with the special and General

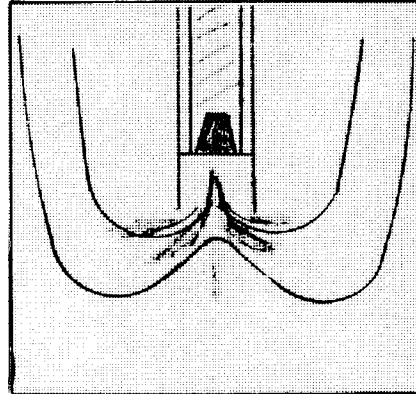

Fig. 3. Illustration showing warped space due to empty body tube and divergence of exhaust along equipotential lines.

theories. For instance, many modelers are dismayed by the blurred aerial photographs they obtain. They are urged to keep in mind that the Lorentz contraction makes the lens thinner while keeping the radius constant. This changes the density of the glass and hence its index of refraction and it also varies the focal length of the lens. Thus, it is not the manufacturer’s fault. To avoid the blurring, use a slow rocket. If you make modifications on the lens, please don’t use a

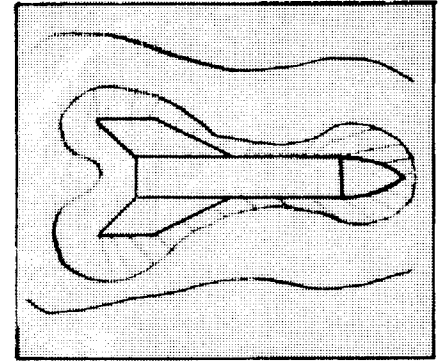

Fig. 4. Illustration showing warped space, warped body tube and resulting expanded boundary layer causing increased drag.

massive glass one, as it will warp its surrounding space and disperse the light somewhat before it hits the film. As is to be expected, massive fins and nose cones (plywood) will cause pressure drag anomalies because they warp the surrounding space and hence the boundary layer; increasing the effective frontal surface area, as is shown in figure 4.

The reader is encouraged to develop these ideas further and to extend the scope of the present relativistic model rocket theory. Relativistic equations, derivations, and references are included for the interested reader.

The author has designed the *Galactic Avenger*, a 6 foot tall rocket, to test his relativistic theory of model rocketry. The first test flight is scheduled for April 1.

1. “Variable Mass Trajectory Analysis; Theory and Experiment” by G.F. Snurdly, Zonal Organization for Weapons, Intelligence, and Espionage.
2. “Search and Discovery,” *Physics Today*, Jan. 1968, Vol. 21, No. 1
3. General Reference: *The Classical Theory of Fields*, by Landau and Lifshitz, 1962 Pergamon Press, Addison-Wesley Pub. Co., Inc.

Riemann Curvature Tensor:  $R^1_{klm}$

$$R^1_{klm} = \frac{\partial \Gamma^1_{km}}{\partial x^l} - \frac{\partial \Gamma^1_{kl}}{\partial x^m} A_l + \Gamma^1_{nl} \Gamma^n_{km} - \Gamma^1_{nm} \Gamma^1_{kl}$$

Equation of the Gravitational Field:

$$R^k_l = \frac{8\pi k}{c^4} T^k_l + \frac{1}{2} \delta^k_l R$$

Time Dilation Equation:

$$t = t_0 \sqrt{1 - v^2/c^2}$$

Mass Change Equation:

$$m = \frac{m_0}{\sqrt{1 - v^2/c^2}}$$



# MODEL ROCKETRY

## DON'T MISS OUT

DON'T MISS OUT on any issues of the new **Model Rocketry** magazine – the only magazine for model rocketeers. Keep in touch with the rapidly expanding hobby-science of model rocketry. Read the latest news on NAR activities – local, regional, and national meets – construction plans – scale info – new materials and methods – math for rocket design – section news – special features – and more!\*\*\*\*\* SUBSCRIBE TODAY!

**Model Rocketry**  
Box 214  
Boston, Mass, 02123

Special Club Rate with 10 or more subscriptions – \$2.75.  
Have your section subscribe!

Please send me (check one):  The next 6 issues \$2.00  
 The next 12 issues \$3.50

Name \_\_\_\_\_

Street \_\_\_\_\_

City \_\_\_\_\_

State \_\_\_\_\_ Zip Code \_\_\_\_\_

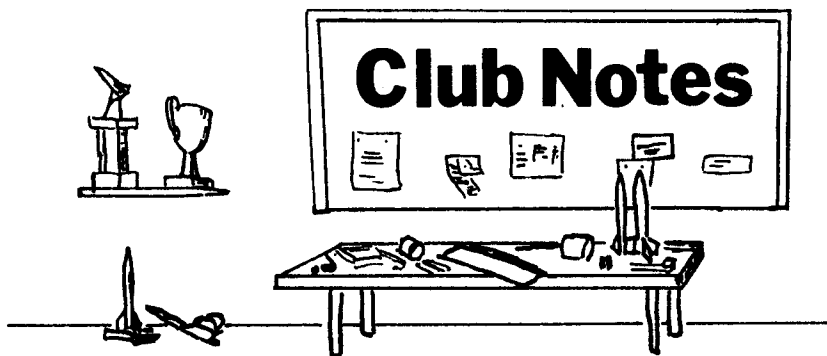

The Xaverian High School Model Rocket Society recently published Volume 1, No. 1, of their newsletter. They report their first section meet will be held towards the end of March, and will include a record trials as well as normal contests. One club member, Stephen Tedesco (NAR 13226), is working on a project to optimize altitude on a two-stage model rocket. He is investigating second stage ignition when peak altitude of the first stage is reached, and second stage ignition when the first stage reaches maximum velocity.

The latest issue of *Igniter Current*, published by the Fairchester Section of the NAR, reports the cumulative contest points for 1969 from that section. Charlie Duelfer leads with 149 points, followed by Rich Sternbach, 113; Jim Bosse, 106; Gary Bump, 80; John Drake, 67; Steve Glines, 54; Bruce Shay, 49; Greg Scinto, 45; John Lane, 14; Jeff Guill, 14; Ninabeth Guill, 4; and Lonnie Mendelsohn, 4. The Fairchester Section also reported that six more contests are scheduled before the Nationals in August.

A new model rocket club, so new it doesn't yet have a name, has been formed in Girard, Ohio, according to information received from William Drescher. Their first contest was held in January. The meet, judged by Jim McCluskin, was won by Bradly Curl, with Bill Drescher second, and Mike Drescher third.

The Rockets Unlimited club of Elkhart, Indiana, is looking for some competition in northern Indiana or southern Michigan. Any group interested may contact Steve Smith, RR No. 6, Box 243, Elkhart, Indiana 46514.

The National Association of Rocketry has announced a contest for the best NAR Section newsletter series published from August 1968 to NARAM-11. Entries should be sent to Miss Elaine Sadowski, 1824 Wharton Street, Pittsburgh, Pennsylvania, 15203. The contest is open to NAR Sections only. A trophy, sponsored by one of the news media, will be awarded to the winning section at NARAM-11.

The first edition of *The Skymasters Newsletter*, published by the SDAR Skymasters, Robesonia, Pennsylvania, reports on the club construction project—the Gamma I. This two-stage rocket, powered by Mini-Max engines, stands 45 inches tall, and is painted white, silver, and black. Construction was completed on November 21, 1968 by Fred Gerhart, James Heist, and Carl Hess. The first public launching of Gamma I is set for May 4, 1969, at Cape Saturn (Womelsdorf RD No. 1, Penna.).

The Skymasters also report the results of the 1968 "Ham on Roll" sale, a unique way of adding to the club treasury. Orders were taken from residents of the towns of Robesonia, Womelsdorf, and Wernersville, on the weekend of August 3. Eight club members collected 558 ham sandwich orders and phoned them in to Mays Sandwich Shop. The club collected \$75 for their efforts.

Send your club or section newsletters, contest announcements and results, and other news for this column to:

Club News Editor  
**Model Rocketry Magazine**  
 P. O. Box 214  
 Boston, Mass., 02123

(From the Editor continued)

space companies, and the hobbyists themselves. The funds collected should be sufficient to send an American team to the World Championships, as well as paying for transportation of the winning modeler in each section to the Nationals.

Only if a clear and workable policy is formulated quickly, will the United States be well represented at the Championships. It is the responsibility of the National Association of Rocketry, as well as all active model rocketeers to meet this challenge.

## HOBBY SHOPS

Your local hobby shops can supply balsa wood, decals, tools, paint, magazines, and many other model rocket supplies.

Mention *Model Rocketry* to your local hobby dealer.

Western New York Headquarters for Rockets and Supplies is  
**GRELL'S FAMILY HOBBY SHOP**

5225 Main St.  
 Williamsville, New York

Open 7 days a week

Phone 632-3165

For all Canada it's

**Dundas Hobbies**  
 811 Dundas, London/Ont.

Sole dealer for Estes  
 Mail Orders Filled

Buffalo and Western New York's  
 No. 1 Rocket Center  
*Estes - Centuri - MRI Rockets*  
**Howard Ruth Hobby Center**

1466 Genesee St.  
 Buffalo, N.Y.  
 Join Our Rocket Club!

Tell your Hobby Dealer you saw it in  
**MODEL ROCKETRY**

Only \$1.00



This full color reproduction, 8½ by 22 inches in size, and suitable for framing can be yours for only \$1.00 (or 6 for \$5.00), plus 25 cents for postage from:

**ASTRO PHOTOS**  
2278 West 6th Street  
Brooklyn, New York

Limited Supply!

Order Your Copy Now!

**ASTRO PHOTOS**  
2278 West 6th Street  
Brooklyn, New York

Full Color Photo

Taken by  
**APOLLO 8 Astronauts**

This spectacular view of the rising earth greeted the Apollo 8 astronauts as they came from behind the moon after the lunar orbit insertion burn. The surface features visible on the moon are near the eastern limb of the moon as viewed from the earth. The lunar horizon is approximately 780 kilometers from the spacecraft. The width of the area photographed is about 175 kilometers at the horizon. On the earth, 240,000 miles away, the sunset terminator bisects Africa.



# ROCKETS

FLIGHTS UP TO 2500 FT.

*Count down with Estes Rockets, and lift off with the very best in model rocketry. Order the Estes Starter kit today. Let the Estes program of model rocketry guide you in the challenge of design, exploration and experimentation in a whole new range of space science interests.*

Ideal father-son activity and hours of fun for all the family

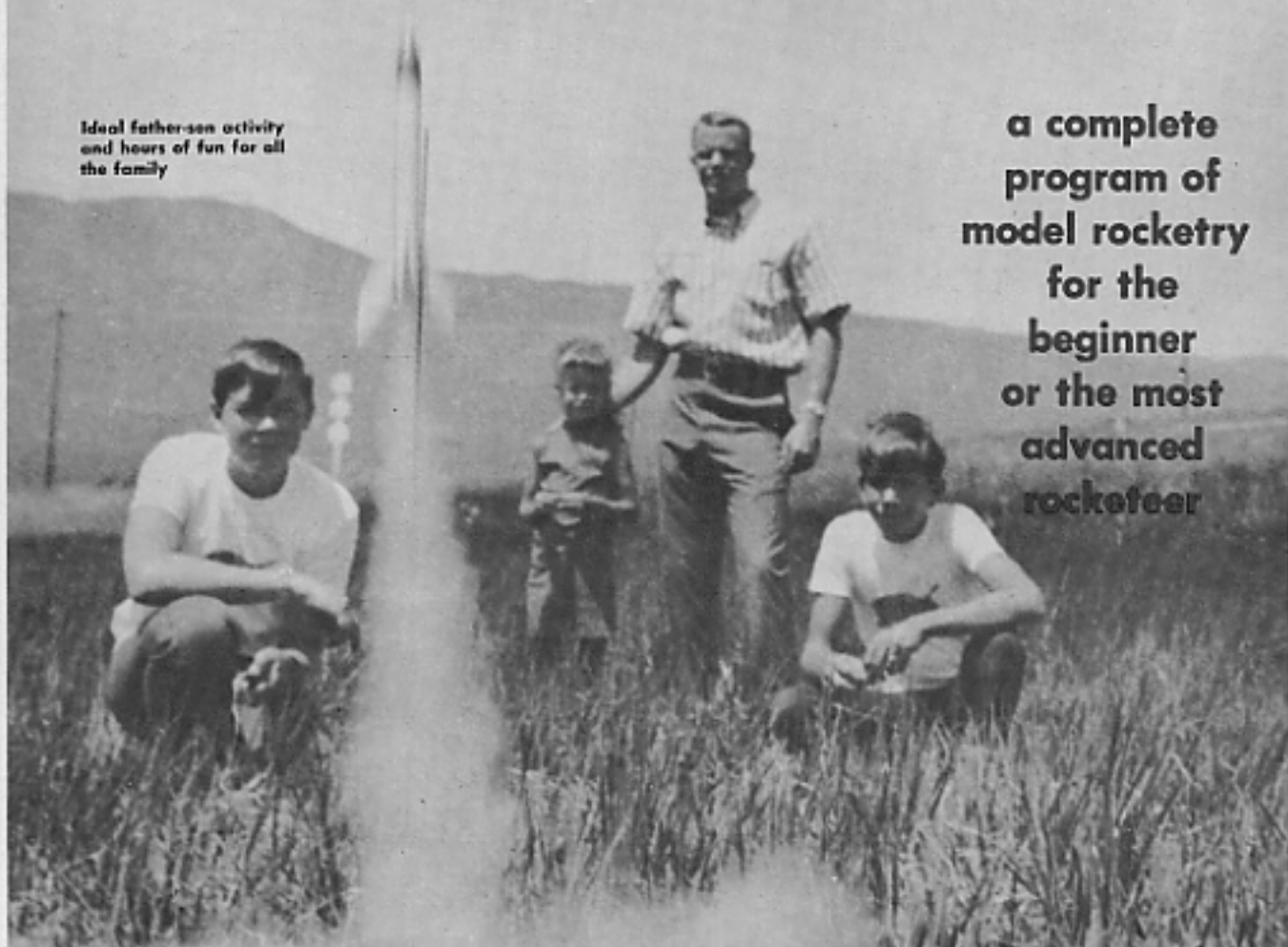

a complete program of model rocketry for the beginner or the most advanced rocketeer

Look for Estes rockets at your hobby store

IF NOT AVAILABLE  
SEND THIS COUPON

Estes Industries, Dept. 31 — Box 227, Penrose, Colo. 81240

Please send me the following:

- Starter Special #DSK-20. Includes high flying Astron Alpha kit, 2 powerful engines, complete instructions and design manual ..... \$2.00
- #DSK-65 — Same as above plus electric launching system, with batteries ..... \$6.50
- Huge, illustrated color catalog ..... (free with kit order) ..... 25¢

NAME ..... ADDRESS .....

CITY ..... STATE ..... ZIP .....