

# MODEL ROCKETRY

March 1969

35 ¢

The Journal of Miniature Astronautics

THE DYNAFLORA

AERIAL PHOTOGRAPHY

DYNAMIC STABILITY

THE BIFURCON

CLUB LAUNCH PANEL

SCALE: GENIE (MB-1)

FINISHING MODROCS

PLUS REGULAR FEATURES

**SATURN-V BUILT BY OTAKAR SAFFEK  
OF CZECHOSLOVAKIA**



**DON'T MISS OUT**

**4th Annual Pittsburgh Spring Convention**  
**March 28-30 Shadyside Academy, Pittsburgh, Pa.**

**Highlights:**

- \*Learn the Latest on R&D, Computer Usage
- \*Explore Scale Models and Boost Gliders
- \*Learn What Makes NAR Championship Models
- \*Learn About the NAR
- \*NASA Demonstrations
- \*NASA Films and Displays
- \*Get the Latest Model Rocket Plans and Info
- \*Model Rocket Launch

The Pittsburgh Spring Convention, hosted by the Steel City Section of the NAR, is designed to bring together model rocketeers of all ages and experience to discuss advances in and ways to stimulate model rocketry. Discussion groups will be led by NASA and NAR officials, model rocket club presidents, and by national championship rocketeers. Topics to be discussed include computer applications, construction techniques, research and development, scale modeling, and boost-glider technology. Talks will also be given on Man in Space, Rocket Propulsion Systems, and Space Medicine. The cost is \$21.00 and includes all fees for the weekend including food and lodging. It does not include transportation to and from Pittsburgh. Space is limited, don't miss out. Reply immediately.

**For more information write: Pittsburgh Spring Convention**

**c/o 1051 N. Negley Avenue Pittsburgh, Pa 15206**

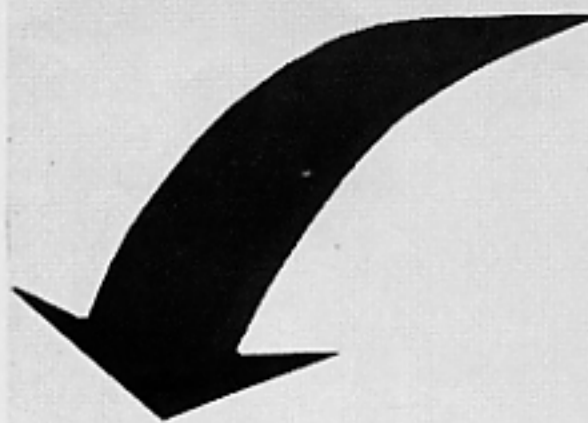

**SPECIAL FEATURES**

- \*Northeast Regional R & D Meet
- \*Guest speakers
- \*Discussion Groups
- \*Launch
- \*2 Banquets
- \*Model Rocketry and NASA films
- \*Computer Demonstrations and Flight Simulations
- \*Technical Report Presentations
- \*Manufacturer's Displays

**2nd M.I.T. NATIONAL MODEL ROCKETRY CONVENTION**

**Approximate Cost for 3 days and Hotel Accomodations—\$25**

**April 12-14, 1969**

For Information, Write to:

George Caporaso  
Convention Chairman  
MIT Branch PO Box 110  
Cambridge, Mass. 02139

# Model Rocketry

Volume I, No. 5

March 1969

Editor and Publisher George J. Flynn  
 Managing Editor Gordon K. Mandell  
 Business Manager George J. Caporaso  
 Distribution Manager Thomas T. Milkie

This month's cover shows the 1:100 scale Saturn-V built by Otakar Saffek of Czechoslovakia for the May 1968 Dubnica Internationals. **Model Rocketry's** exclusive coverage of Saffek's fine model begins on page 6. (Cover photo by Otakar Saffek.)

## From the Editor

Once again, the convention season has arrived. Model rocketeers from many parts of the country will gather together, listen to presentations, and perhaps stimulate each other to look for solutions to some of the common problems of model rocketry. The Pittsburgh Convention in March and the MIT Convention in April will each attract interested model rocketeers from their regions. However, it seems unlikely that many of the young model rocketeers who live a considerable distance from Boston or Pittsburgh will be able to attend a convention this year. It is time that ambitious model rocket clubs make plans for a regional convention in their part of the country for next year.

In order to promote the sport of model rocketry, *communication* between the participants must be increased. Right now, we have the National Championships attended by perhaps 100 rocketeers in midsummer, a small number of conventions in the spring, and an increasing but still small number of area and regional competitions during the year. The vast number of model rocketeers in this country are highly "club oriented" - maintaining close contact with a limited group of rocketeers but ignoring the activities of the tens of thousands of other active hobbyists.

In order to encourage an extension of communication in the hobby, interested clubs and the national organizations have a responsibility to establish regular regional

(Continued on page 31)

|                                                                  |    |
|------------------------------------------------------------------|----|
| The Old Rocketeer: Saffek's Saturn<br><i>by G. Harry Stine</i>   | 6  |
| High Quality Aerial Photography<br><i>by Richard Q. Fox</i>      | 8  |
| The Bifurcon<br><i>by Thomas T. Milkie</i>                       | 10 |
| Constructing a \$25 Club Launch Panel<br><i>by Roger Golub</i>   | 13 |
| How to Finish a Model Rocket<br><i>by Thomas T. Milkie</i>       | 14 |
| Scale Design: Genie (MB-1)<br><i>by George Flynn</i>             | 16 |
| The Dynaflora<br><i>by George Caporaso</i>                       | 22 |
| Fundamentals of Dynamic Stability<br><i>by Gordon K. Mandell</i> | 25 |
| Underground Songs of the NAR                                     | 31 |
| <b>Features</b>                                                  |    |
| Letters to the Editor                                            | 2  |
| News Notes                                                       | 5  |
| Technical Notes                                                  | 9  |
| Reader Design                                                    | 17 |
| Q & A                                                            | 21 |
| Photo Gallery                                                    | 24 |
| Club Notes                                                       | 32 |

Model Rocketry magazine is published monthly by Model Rocketry, Inc., Box 214, Boston, Massachusetts 02123.

Subscription Rates: U.S. and Canada, \$3.50 for 1 year; \$2.00 for 6 months; 35 cents for single copy. Foreign, \$6.00 for 1 year; \$3.50 for 6 months; 60 cents for single copy.

Material submitted for publication should be accompanied by a self-addressed, stamped envelope if return is desired. We can assume no responsibility for material lost or damaged; however care will be exercised in handling.

Advertisers should contact Advertising Manager, Model Rocketry, Box 214, Boston, Massachusetts 02123 for advertising rate cards and information.

© Copyright 1969 by Model Rocketry, Inc.

## SPECIAL OFFER!

Beautiful, full-color photograph of the Apollo 7, Saturn 1B liftoff of October, 1968

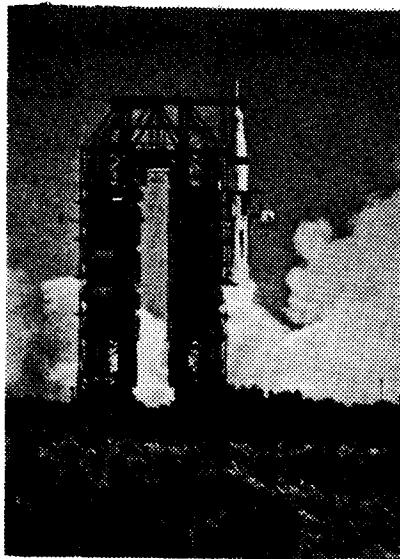

This magnificent photograph of a most historic moment in the history of spaceflight was obtained by Model Rocketry editor George Flynn from an advance position not accessible to most Kennedy Space Center visitors. Showing the moment of liftoff, this 7 by 8 inch full-color print will make an inspiring addition to the album of any space enthusiast.

Full-color copies of the photograph, which is reproduced in black and white above, may be obtained by sending 50¢, or \$1.00 for 3, to:

Saturn Photo  
Model Rocketry  
Box 214  
Boston, Mass. 02123

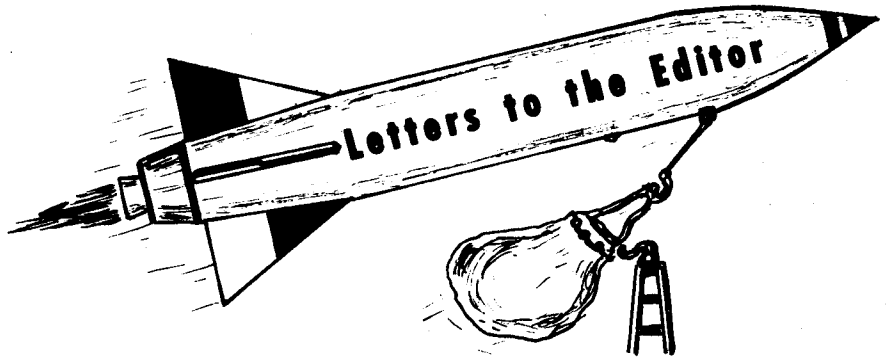

### Careers in Rocketry

In high school I couldn't decide what field I wanted to go into as a career, until in the summer of 1965 when I answered an advertisement in a magazine. Two weeks later I received a catalog from Estes Industries. After that I was hooked on model rocketry and became one of the founding fathers of the Nicolet High School chapter of the NAR. Later I also decided to make Aerospace Engineering my career. Now I'm in my sophomore year at college and I'm determined to graduate. I even have a summer job working for NASA at Edwards AFB, Calif.; working on such sophisticated aircraft as the F-111, the XB-70 supersonic bomber, the HL-10 and other lifting bodies (space re-entry vehicles), and the X-15. I'm also president of the Iowa State University Model Rocket Society which I organized last spring. Today I have a fairly bright future ahead of me because of model rocketry.

I recommend any model rocketeer in high school to seriously consider turning his hobby into his career and become an Aerospace Engineer. I consider model rocketry as *THE* gateway to the future.

Sorry I didn't write to you sooner. I just got back from Calif.

John A. Quandt  
Ames, Iowa

### Rocket Design

Please send me the January 1969 and February 1969 issues of *Model Rocketry* as the first part of my subscription - I had a slight misunderstanding with my dealer regarding these issues and I didn't get them.

I am in the process of designing and building a rocket to test the "coke bottle" shape and need installment three of *Fundamentals of Dynamic Stability* to be able to design the fins.

I have been a rocketeer for about two months, but am very enthusiastic about it. Myself and some friends are in the process of forming a club and getting a permanent launch site. Although new to rocketry, I have been a modeller since age 5 (I am now

20) and am experienced in modeling besides already having some good tools (among them a Unimat which I turn many of my own parts on.)

I am currently a Junior at the University of Santa Clara and am majoring in Mechanical Engineering. Among the things myself and two close friends are working on are: the "coke bottle" shape rocket; a transmitter that *does* fit in about 2½ inches of Estes BT-20; inertial guidance systems; no-lug launching; and sending a mouse up with telemetry on certain bodily functions. I am trying to work model rocketry into a senior thesis project.

Two recent articles that really caught my interest were *Model Rocket Recovery by Extensible Flexwing* and *High Quality Aerial Photography*. I can't wait to try them.

It's really great to have a magazine like yours. It can't help but create even more interest. I wish you much success - the sport needs you!

Dennis Romano  
Campbell, California

*We wish you luck on the projects you are undertaking, and hope you will submit articles on them to Model Rocketry when they are completed.*

### CENSORSHIP

It is with great fear and trepidation that I write this letter. Even its postmark may give the fearsome forces lurking in your domain a clue to my location. . . and should they find me, it means certain doom. But, in the name of righteousness, I find myself morally bound to point out a few facts—to you, and, if by some miracle this manuscript is found by some worthy individual, to your readers.

Last month, an article appeared in *Model Rocketry* entitled: "Model Rocketry for the Really Depraved." It was asserted that I was the sole author of that creation. Indeed, initially I was. But, somewhere between my typewriter and your printing press, a collaborator appeared, totally unbeknownst to me. This collaborator committed a crime so terrible. . . so villainous. . . so atrocious that

I shudder to mention it, but mention it I shall, if for no other reason than to help make the world safe for democracy(sic). That example of blackhearted evil was . . . CENSORSHIP. Yes, the following passage was treacherously omitted from my article:

. . . I fondly remember the good old days when I used to bombard the housing project on the next hill with two-stage rockets, built my first bazooka, or built and fired flare rockets containing an amazing assortment of explosives and incendiaries. I remember one that had . . . (there followed a list of pyrotechnics it serves no purpose to mention here). . . Beautiful!!— ah, but no more.

Now just why would some fiend want to eliminate such an artistic passage. I wasn't sure, so I decided to check your offices. Before I had worked my way past the third chief assistant to the Assistant Chief of Publication, I was halted by an undoubtedly evil creature — perhaps a man— flanked by uniformed guards with sub-machine guns and — as one might guess — rocket pistols. Only later did I discover that these guards were members of an ultra-secret branch of the NAR, the dreaded SS (Safety-code Stompers). It seems that whatever little man (known only as "fearless leader") who sits in some dark corner of your offices and viciously denies freedom of expression to naive young rocketeers had decided that I knew too much. I was to be censored!!! Fortunately, much to the shock of the guards, I was able to zap them with a pocket tesla coil and make good an escape to the roof. By the time they recovered and got up themselves, all they found was some scorched nichrome. I had flown the coop.

I thought I was safe then. . . but little did I know the thoroughness of the plot. Even now, I am still fleeing their pursuit. My only chance is a change of heart at the top. If there is some spark of decency. . . some last vestige of those classic and eternal values of Truth, Justice, and the American Way left in your magazine, please — try to rescue it now. Turn your administration away from the stygian blackness of the deep depths of evil to the glorious light of a bright new literary future. Let there be freedom of expression for all! Your chance is here; the time is . . . NOW! Scientia Omnia Vincit.

Sincerely yours,  
Joel S. Davis  
Pittsburg, Pa.

*We regret Mr. Davis is not happy with our editing of his article. However we should like to explain that the single paragraph was deleted because, as Mr. Davis correctly observes, it contained a list of pyrotechnics it served no purpose to mention there. Model Rocketry will not encourage the construction of bombs of the type Mr. Davis attempted to describe.*

#### Praise

Just a word of thanks to everyone who makes this magazine possible. I've always wanted a model rocketry magazine, and now we've got one! I'm sure you will get many people further acquainted with rocketry, and I know your magazine will be a great success.

Thanks again!

H. Scott Krause  
Cleveland, Ohio

I've been a model rocketeer for five years and I am glad a magazine devoted to the subject has finally been published. Please find enclosed my \$3.50 for a year's subscription.

John R. Lee, Jr.  
Tulsa, Oklahoma

I am glad to see that a magazine has come out on model rocketry. Keep everything you have in it. I am looking forward to the next issue.

Thomas Hendrickson  
South River, New Jersey

*We would like to take this opportunity to thank all of the many readers from all parts of the country who have taken the time to send us words of encouragement over the past few months. Many of you have asked what you can do to help us in our efforts to bring the hobby of model rocketry to the attention of larger numbers of hobbyists. We hope you will show copies of Model Rocketry to your friends and encourage them to subscribe in order to promote communications in the hobby. Also, we hope you will send us your ideas on model rocketry. — These can be in the form of short notes or letters, articles for publication, or just information on what you and your friends are doing in your own area.*

#### Micrometeorology

I recently received the January issue of *Model Rocketry*, and, as usual, immediately read it from cover to cover. I think the sport and hobby of model rocketry has needed a magazine such as your's for a long time.

In the *Letters to the Editor*, I noticed several letters from persons who couldn't cope with some of the higher math used in your fine technical reports. Being only a senior in high school, I was faced with the same problems. However, I feel that I have no right to call myself a serious rocketeer if I don't constantly strive to increase my knowledge of the subject. I've been having conferences with my high school math teacher, and she has been great about explaining some of the computations to me.

The interest that you have expressed in getting more hobbyists to do serious experi-

mentation has had its effect on me. In the *From the Editor* column of the November issue, you made mention of the fact that model rocketry may be used in the field of micrometeorology. I have been thinking on the subject, and doing a little research, and have not been able to come up with anything. If you could please give me a few hints as to how I might be able to apply model rocketry to research in micrometeorology, I would be very grateful.

Once again let me thank you for your contributions to the field of miniature astronautics. You have a great magazine, and I foresee a successful future for it.

David Haley  
Cheraw, So. Car.

*Micrometeorology is concerned with the surface boundary layer of the atmosphere—about the first 50 meters. In this layer, the meteorological measurables wind, temperature, and often humidity vary extremely rapidly with height and with time. However, except within the first meter or two above ground, the magnitudes of these changes are often quite small. Thus, variations ignored in most other branches of meteorology are extremely significant in micrometeorology. Temperatures, for example, must be measured to about 0.1°C. in actual micrometeorological research. The reason for the importance of these tiny fluctuations in the variables is that turbulence—random gustiness of the wind—is very important in this boundary layer, and must be measured. The accuracy required for real research in micrometeorology is currently beyond the state of the art of model rocketry.*

*However, there are some experiments which can be done with model rockets—at least in theory—which could yield some good data. A model rocket can be used to produce a smoke puff at a pre-determined altitude (within about five meters). This smoke puff can be used to trace the winds, by a process of triangulation, similar to that used for altitude tracking, using several observers for best accuracy. Upward and downward motion, and the time required for the smoke cloud to dissipate, will give a relative measure of the turbulence.*

*Also, a rocket with a large parachute could be used to follow the wind pattern (roughly). Irregularities in its descent will indicate total turbulence.*

*Try these experiments at different times of day, and on moonlit nights, to compare the state of the atmosphere at various times. Determine the times of maximum and minimum turbulence.*

*If you are willing to risk some rockets for the cause of science, try some of these experiments near lakes and forests, to observe the differences in wind patterns over different types of terrain.*

*Other measurements in micrometeorology will be a lot harder to perform, and somewhat more expensive. Temperature and humidity data are routinely obtained to*

within 0.1°C. (dry and wet-bulb temperatures) with thermocouples. These devices indicate a temperature difference between the atmosphere and a known reference temperature (like an ice-water mixture) as a voltage. Also, resistance in a regular way with temperature change—give the same accuracy. Since the height of your rocket can be determined at all times after deployment by triangulation (done very carefully, of course!), temperature and humidity as functions of height can be determined using two thermocouples or resistance thermometers, one wrapped in a moistened wick. The following practical problems will arise:

- 1) Lifting the instruments without damaging them
- 2) Deployment of instruments

3) Light-weight radio transmitter to return the data

4) Cost!

And, of course,

5) Murphy's Law.

Also, when an inexpensive and reliable radio transmitter becomes available (one will be described in a subsequent **Model Rocketry** article), it may be possible to do some research in cumulus-cloud-scale and even mesoscale phenomena (especially the behavior of the atmosphere above the boundary layer but below the cumulus cloud base), using techniques developed in micrometeorological research.

You have picked a difficult field to cover inexpensively with model rockets—or anything else, for that matter. However, the

fact that costs may initially be high for anything but smoke-cloud tracer work should provide an interesting challenge. If the results of your work cut the cost of good observations in the boundary layer significantly, that alone will be a valuable contribution to micrometeorology, especially to amateur micrometeorology. Further information on the subject of micro meteorology can be found in **Descriptive Micrometeorology**, by R. E. Munn (*Advances in Geophysics, supplement 1, 1966, Academic Press, New York and London.*). Some portions are quite technical, but the first six chapters are well worth reading.

Good luck, and keep us posted on your progress.  
—Arthur Polansky

## SOLICITATION OF MATERIAL

In order to broaden and diversify its coverage of the hobby, **MODEL ROCKETRY** is soliciting written material from the qualified modeling public. Articles of a technical nature, research reports, articles on constructing and flying sport and competition models, scale projects, and material relating to full-scale spaceflight will be considered for publication under the following terms:

1. Authors will be paid for material accepted for publication at the rate of two dollars (\$2.00) per column inch, based on a column of eight-point type thirteen picas wide, for text, six dollars fifty cents (\$6.50) for drawings, and two dollars (\$2.00) for photographs accompanying text. Payment will be made at the time of publication.

2. Material submitted must be typewritten, double-spaced, on 8½ by 11 inch paper with reasonable margins. Drawings must be done in India ink and must be neat and legible. We cannot assume responsibility for material lost or damaged in processing; however our staff will exercise care in the handling of all submitted material. An author may have his manuscript returned after use by including a stamped, self-addressed envelope with his material.

3. Our staff reserves the right to edit material in order to improve grammar and composition. Payment for material will be based on the edited copy as it appears in print. Authors will be given full credit for published material. **MODEL ROCKETRY** will hold copyright on all material accepted for publication.

Those wishing to submit material should send it to:

Editor

Model Rocketry Magazine

P.O. Box 214

Boston, Mass., 02123

# News Notes

## NARAM-11 Planning Continues

### NAR, Air Force Meet

The 11th National Model Rocket Championships are now scheduled to be held from August 11 through 15, 1969, at the United States Air Force Academy, Colorado Springs, Colorado. Details of the event were worked out in a meeting between officials representing the National Association of Rocketry, the Civil Air Patrol, and the Air Force Academy. Those attending were Bill Roe, representing the NAR; USAF SSgt. Larry Loos, editor of the Model Rocketeer; Vic Cross, from the Metro Denver Rocket Association; George Roos and Glen Osbourne, Flight Systems, Inc.; Lt. John Wilson, CAP; Capt. Harry Kepner USAF, project officer for NARAM-11; Capt. J. M. Koonce USAF, representing the Cadet Model Engineering Club; and Capt. Harvey Brock, Jr. USAF. Vern Estes of Estes Industries, Inc., was unable to attend due to illness.

The Air Force Academy airstrip will be made available as a launching site. Meeting rooms will not, however, be available at the

airstrip, they will be located some distance away in an Academy building. No quarters will be available at the Academy, so the Contest Director—William Roe—will make arrangements for hotel or motel rooms in the Colorado Springs area. There will be limited bus transportation to and from the quarters. Range equipment for NARAM-11 will be requested from the Civil Air Patrol, model manufacturers, and NAR sections. Since the Academy also hosted NARAM-4 in 1962, past experience should facilitate preparations for this competition.

### There's Been a Change

... in the address of the Bo-Mar Development Co., Inc., the new model rocket manufacturer doing business out of Liverpool, New York. Their corporation has been reorganized and they can now be reached at 534 Kenwick Drive, Syracuse, New York 13208.



Photo by Walt Good

To commemorate man's flight to the Moon, a presentation of a model of the Saturn-V moon rocket was made to Charles Hennecart, Secretary General of the Federation Aeronautique Internationale (left), by the Chairman of the FAI Rocketry Subcommittee, G. Harry Stine of the United States (right). The FAI certifies all international space and aeronautics records.

Back issues of Model Rocketry are available at 35 cents (plus 15 cents postage) each while the supply lasts. Feature articles include:

### October 1968

Dragstab: A finless rocket .....  
Wallops Station. .... Model Rocket  
Altitude Calculations. . . . Apex I:  
A high altitude rocket. ....  
Egglofter II. .... Fundamentals of  
Dynamic Stability, Part I. ....  
Bomarc B Scale Design . . . . .

### November 1968

Model Rocket Recovery by Extensible Flexwing. .... High Quality Aerial Photography, Part 1. ....  
Calculating Drag Coefficients. ....  
Scale: MT-135. .... Project Apollo  
..... XR-5C: Three Stage Cluster  
Rocket Design. .... Fundamentals of Dynamic Stability, Part 2. ....  
The Versitex: A payload rocket . . . . .

### January 1969

The Stygion: A Rocket with Card-board Fins. .... Designing a Club Launch Panel. .... Using Super Monokote. .... High Quality Aerial Photography, Part 2. .... Scale Design: Viking IV. .... Fundamentals of Dynamic Stability, Part 3. .... Sounding Rockets. .... A Minimum Resistance Launch Panel . . . . . Avenger II: Two Stage F-engine Altitude Rocket. .... A Problem in Stability . . . . .

### February 1969

Zeta Single Stage Sport Rocket Plans. .... The Flight of Apollo 8. .... Fundamentals of Dynamic Stability, Part 4. .... Non-Vertical Trajectory Analysis. .... The Old Rocketeer. .... Cosmic Avenger: Construction for Class E Engines . . . . . Scale Design: Nike-Deacon . . . . . Model Rocketry for the Depraved. .... World Championship Scheduling Report . . . . .

Send your back issue orders to:

Back Issues  
Model Rocketry  
Box 214  
Boston, Ma. 02139

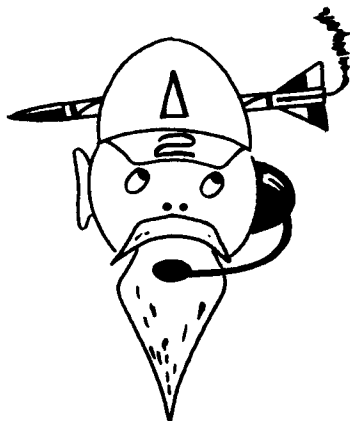

# The Old Rocketeer

by G. Harry Stine NAR#2

## Saffek's Saturn

The Second International Model Rocket Competition was held in Dubnica nad Vahom, Czechoslovakia in May 1968. This time, the USA was not able to get a team there to compete. But we got a rather complete report from Otakar Saffek, the Chairman of the CSNAR (Czechoslovak National Association of Rocketry).

A Scale event with rules based on those in the NAR's U.S. Model Rocket Sporting Code was flown for the first time in Europe, and Scale competition caught on quickly over there.

The photos accompanying this article show Otakar Saffek's fantastic Saturn V

entry built to a scale of 1:100.

When your reporter was in Prague in February 1968 during the Winter Olympics, a set of NASA's Saturn V plans available from NAR's Technical Services found their way into Saffek's hands.

Five months later, Saffek had built the Saturn V model in the photos... *FROM SCRATCH!*

Most of us in the USA are really spoiled when it comes to model rocketry. We have the world's best balsa wood to use. Manufacturers make available a wide variety of body tubes. We can find various plastics for use in models by looking in the yellow

pages of the telephone directory. Or we just take the lazy man's way out and buy a pre-fabbed kit.

This isn't the way it is done in Europe. They don't have the materials, equipment, and facilities that we take for granted. A modeler over there is a *real* modeler. He builds from scratch, taking the basic raw materials and fabricating them to his wishes.

There isn't a pre-fabbed part in Saffek's Saturn V. The various body tubes were all hand-rolled. Details were cut and shaped from blocks of rather poor balsa or hardwood. The corrugations around the interstage structures, for example, were made by gluing string and thread down on the paper or wood part! All details were hand-painted on the model or, in the case of

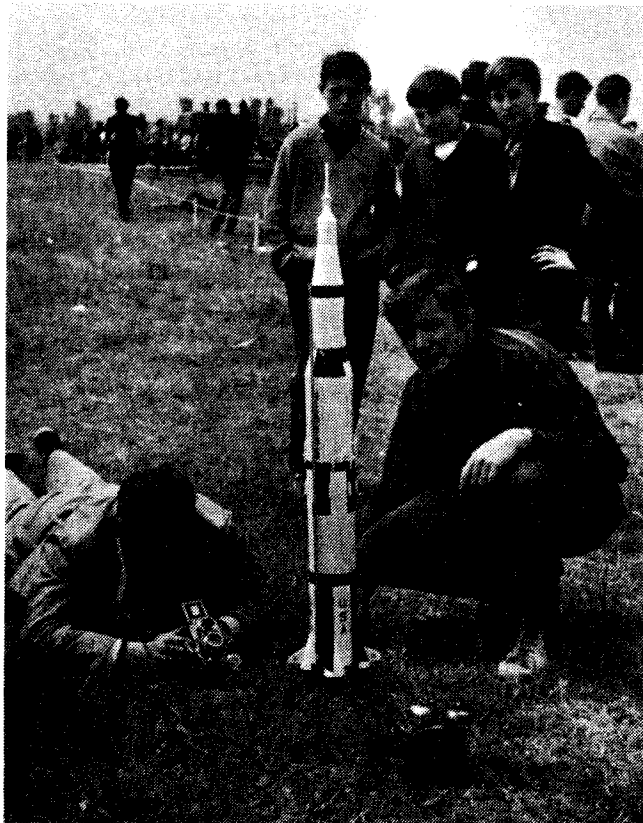

All photos by Otakar Saffek.

The true size of the 1:100 Saturn V is shown here. Otakar Saffek kneels to the right of the model.

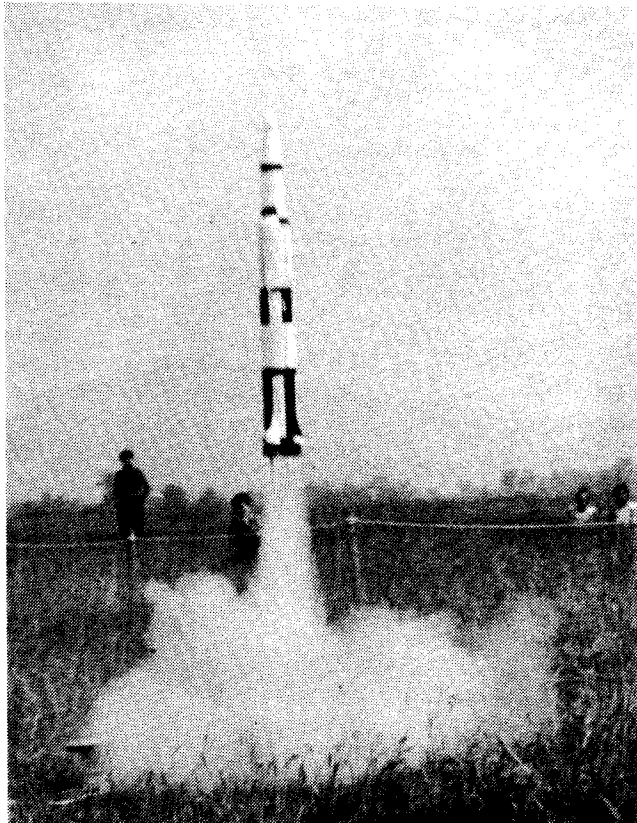

Liftoff! Saffek's Saturn V lifts off from the airfield at Dubnica nad Vahom during the Scale event of the Second International Model Rocket Competition in May 1968. All five ADAST motors ignited.



very small details, put on with *hand-made* decals. (Saffek once told me how to make decals; it is a long, time-consuming, gut-tearing mess!)

Saffek's Saturn V was powered by a cluster of five ADAST RM 5/5 rocket motors. Each of these is equivalent to our USA Type B6-4. Saffek installed the motors in replica scale nozzles of the F-1 engines in the S-1C first stage. The model flew with a total of 25 Newton-seconds of total impulse and achieved an altitude of about 100 meters. The recovery system used two 18-inch Estes plastic chutes as shown. Unhappily, this wasn't enough chute area for the 500-gram model, and it landed rather hard. Some of the tail section was cracked, and the Apollo LES tower was bent up.

"But everything is now fixed," Otar wrote later.

When Otar sent the photos, I had a copy made and sent to Dr. Wernher von Braun in Huntsville, Alabama. Dr. von Braun graciously autographed one of the photos of the model which I forwarded on to Saffek.

This was *before* August 22, 1968.

But you can't keep good modelers down, and we must admit after studying these photos that Saffek is a good modeler indeed. Could *you* build a Saturn V like this from scratch?

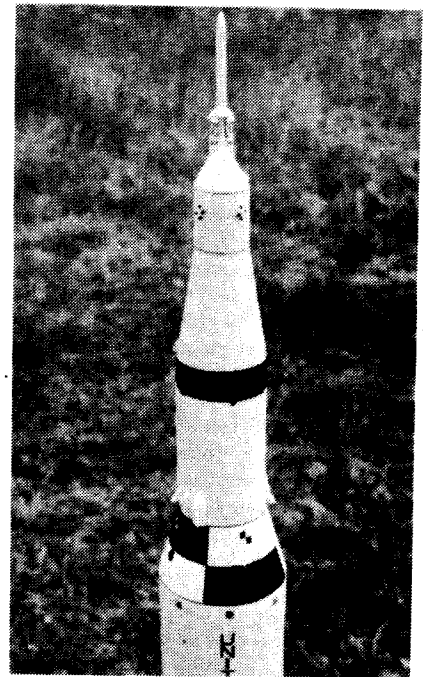
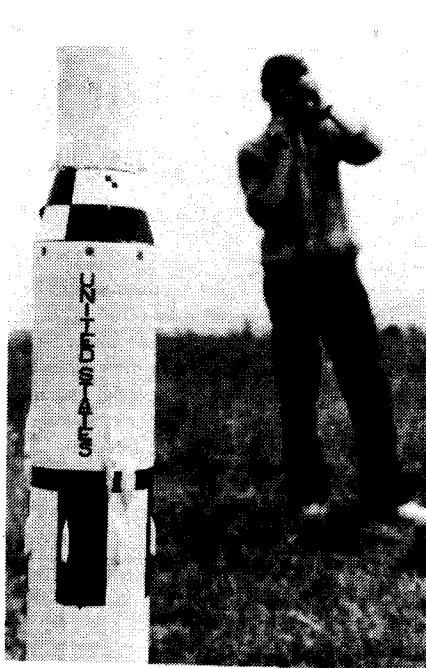

All of the intricate details on the S-II stage and Interstage structures of Saffek's Saturn V model were made from basic materials from scratch with no pre-fabbed parts. Decals and lettering are hand-made.

The detailing around the Apollo payload of Saffek's Saturn V was all done by hand, including the little RCS modules and nozzles. Note the corrugations on the service module and the S-IVB stage.

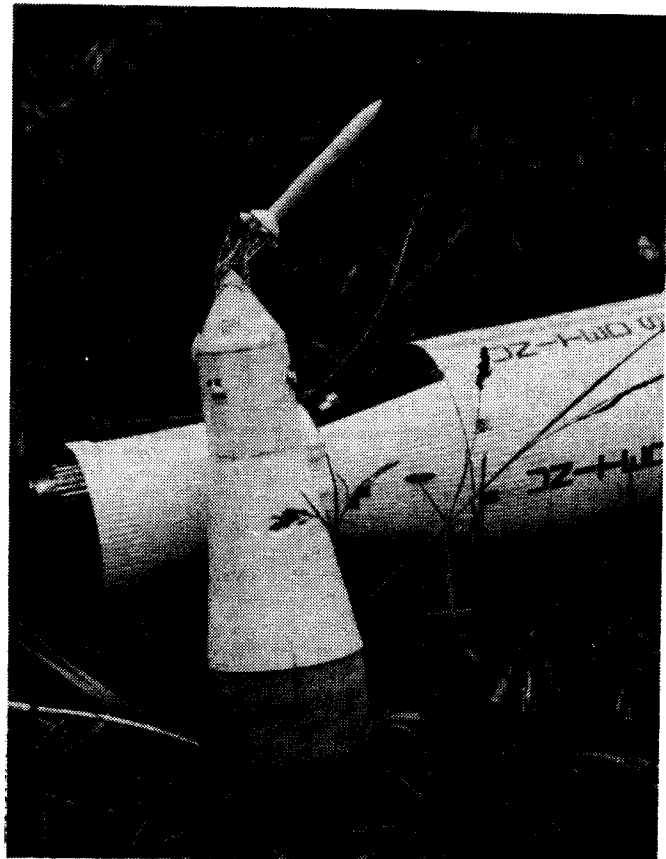

Recovery of Saffek's Saturn V using two Estes 18-inch plastic chutes. Tail section was damaged by hard landing due to rapid descent with small chutes...in spite of Dubnica's tall grass.

A scale modeler's nightmare! The LES tower of Saffek's Saturn V was slightly bent during its hard landing at Dubnica. Saffek reports it is fixed now.

# High Quality Aerial Photography

## Part III Adding a Haze Filter to the Camroc

by Richard Q. Fox

The first installment of this series discussed the basic principles behind the operation of the Estes Camroc, and how to cut and develop film for the Camroc. The second article gave a detailed description of how to install a high quality glass lens in the Camroc. A Camroc using a glass lens and film developed at home can produce pictures which are sharp even when they are magnified six times. However, close inspection of these pictures will reveal that the detail lacks contrast. Frequently, the cause of this problem is not the Camroc itself, but rather haze.

Kodak Tri-X film is sensitive to ultra-violet light (which the eye cannot see), and ultra-violet light is affected by haze in much the same manner as visible light is affected by fog. As a result, a Camroc picture taken on a hazy day will not be sharp, unless the ultra-violet light is screened out.

Aerial photography cameras have been equipped with haze filters for a long time, and in fact these filters are available at any photography store. The Wratten type A and F filters are designed for haze reduction. Filters A and F cannot be used with the Camroc, because they are too dense. In fact, the A filter reduces the effective film speed by a factor of 6. The G filter, on the other hand, is less opaque. It reduces the film speed by a factor of only two. A Camroc

equipped with a glass lens can take well exposed pictures through a type G filter.

There are several ways to mount a haze filter in the Camroc. One method would be to cut out a disk from a sheet of type G filter material and use the disk instead of the plastic nose window. Another, simpler method, is to mount a commercial camera filter on the inside of the Camroc nose cone. A Kodak Series V Wratten G filter (No. 15) fits the inside of the Camroc nose cone very

nicely (See Fig. 1). The filter can be glued in place without any trouble.

The additional weight of the filter may reduce the altitude that the Camroc reaches by as much as ten percent, but the increase in detail of the resultant photographs is very noticeable, as can be seen in the two photographs below. Aerial photographs taken with an Estes Camroc equipped with a glass lens and a haze reduction filter are probably the best that model rocketry has to offer.

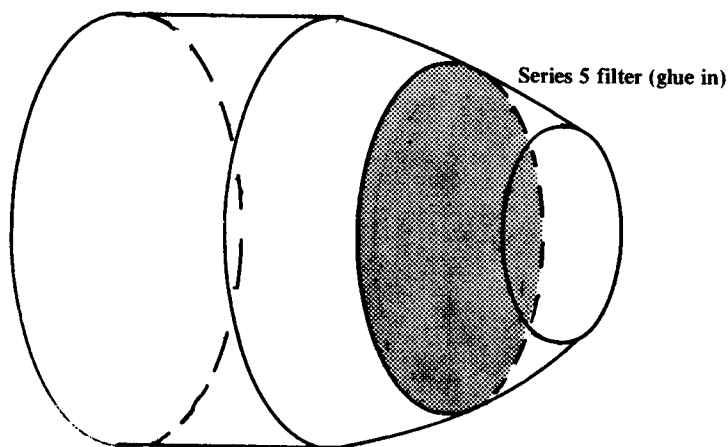

Glue Series 5 filter in the nose end of the Camroc, as far forward as possible.

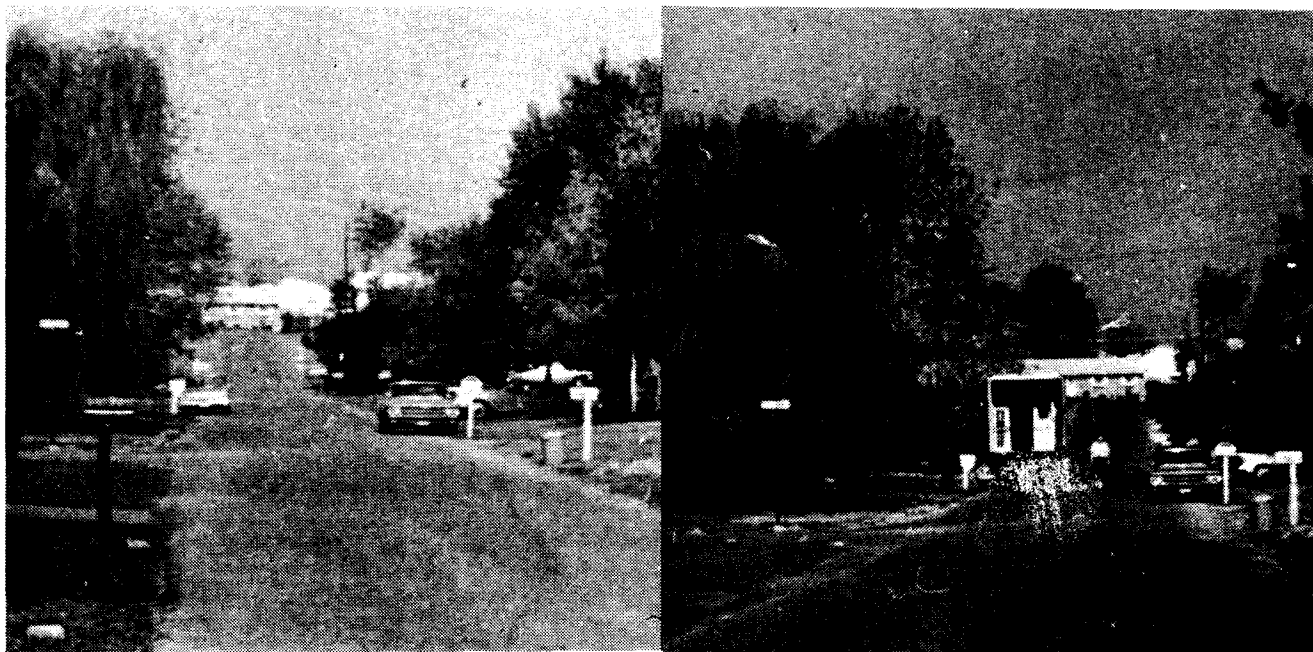

Six power magnifications of Camroc photos showing (left) the image obtained using an Edmund lens, and (right) using an Edmund lens and a Series 5 haze filter.

# Technical Notes

George Caporaso

This month's column will consider the need for reliable tracking equipment in model rocketry. Anyone who has been to an NAR competition or any other altitude meet is well aware of the problem of tracking altitude rockets. According to NAR rules, there must be two optical trackers separated by a suitable base line. Each tracker must compute the altitude separately and compare the two. If the figures don't come within ten (10) percent of each other, or if one or both of the trackers loses sight of the rocket, the track is declared "lost" and no altitude figure is recorded for the contest.

This method of tracking obviously presents great problems for competition and design. It means simply that in order to win an altitude competition a rocket does not necessarily have to reach the greatest altitude, it must merely achieve the greatest trackable altitude. In addition, it must fly slow enough to be seen. Perhaps your 0.8 ounce rocket will go higher with a B3-5 than with a B.8-6 but the trackers may never see it with a B3-5.

Those are some of the problems; now let's consider some possible solutions and alternate methods.

Perhaps the present system would be much more successful if a long burning brightly colored smoke charge could be incorporated into model rocket engines. A charge that burned for 30 seconds would most likely be more than enough to track.

A second modification of the present system that has been proposed is that of a *man-aiding* system. That is, better optical equipment, better tracking mounts, etc. The telescope, monocular or binocular, would still be the heart of the system. It might possibly be made with a "richest field" lens or one with an equally wide field of view. The magnification should be of the "zoom" type, i. e., one where the power can be varied continuously by elongating or compressing the viewing tube instead of by changing eyepieces. The mounts should be of a ratchet type; ones that stay in whatever position they are placed in until moved again by the tracker.

These improvements and modifications might possibly make the present system much more effective, but it still cannot completely solve the problem.

The second general class of systems that might replace the present ones are the

*man-replacing* systems. That is, those that would use electronic and mechanical sensors, tracking mechanisms, computers, etc.

Probably the most considered and most talked about system of this class is that of radar. Unfortunately, there are two major problems with using radar to track model rockets. First of all, most radars are notoriously unreliable at short distances (the range of a model rocket), and the second is that it would require a monstrous amount of input power to the transmission stage of the radar in order to get any power back into the receiver stage because the model rocket has such a small cross-sectional area with which to reflect the radar waves. And since the returning power varies inversely as the range to the fourth power, it would require at least a megawatt of input power. Most airports and government installations have such equipment, but model rocketeers generally don't.

A second electronic method that has been under consideration for some time has been that of a transponder. A transponder is a device that receives a radio signal from a ground base and sends another signal back to the same base as soon as it receives the first. The time between transmission of the signal and receipt of the signal at the ground base is measured on a triggered sweep oscilloscope or other device. The distance from the base to the rocket can be determined by dividing the time in half and multiplying by the speed of light. This is a sound principle and has been used widely in professional rocketry. Such a transponder is highly complicated since it must contain a receiver and a transmitter and a special time lag circuit to shut off the receiver in the transponder while the transmitting stage is on or else the transponder will receive its own signals. I have designed a circuit for a transponder but didn't bother to build it

since even using micro-circuits instead of transistors, its weight came out to about three ounces with the battery. *Most model rockets carrying that wouldn't go high enough to merit tracking anyway!*

Among other methods that have been suggested was that of a laser tracking system. One of the problems with that is developing a mechanism to move the laser to follow the rocket. That problem can be solved but it requires knowledge of sophisticated electronic and mechanical techniques and plenty of money. The laser is no small problem either. They can either be purchased for several hundred dollars or they can be built for about a hundred dollars and many, many hours of work. Either way, it's as impractical as building your own megawatt radar.

Another suggestion has been to make the launch lug into an ultrasonic whistle so that the doppler shift in the pitch of the sound can be detected on the ground and electronically integrated to yield the altitude. It's a cute idea. Perhaps it could work, but it would undoubtedly require very expensive ground support equipment which, of course, would require a relatively vast expenditure (by my meager standards, anyway).

It seems unfortunate in the last analysis, that the only practical, workable tracking system seems to be the present optical one and that no other, usable system is in sight (as far as this near-sighted author can tell).

This is unquestionably one of the most important tasks that can be done in rocketry today. Reliable experiments for altitude, drag and oscillation work can not be performed until this problem is adequately solved.

As always, I will gladly print the results of any rocketeer who has done reasonable work on this or any other technical problem. If there is enough material to your research, you are invited to submit full length articles for publication at our new juicy rate of \$2.00 per column inch (approximately \$50 for a full page of copy). If you have any questions, comments, criticisms or technical news or information about this column or the technical state of model rocketry, please write to:

George Caporaso  
Technical Notes  
Model Rocketry  
Box 214  
Boston, Massachusetts 02123

Join the.....



**National Association of Rocketry**

1239 VERMONT AVE. N.W.  
WASHINGTON, D.C. 20005

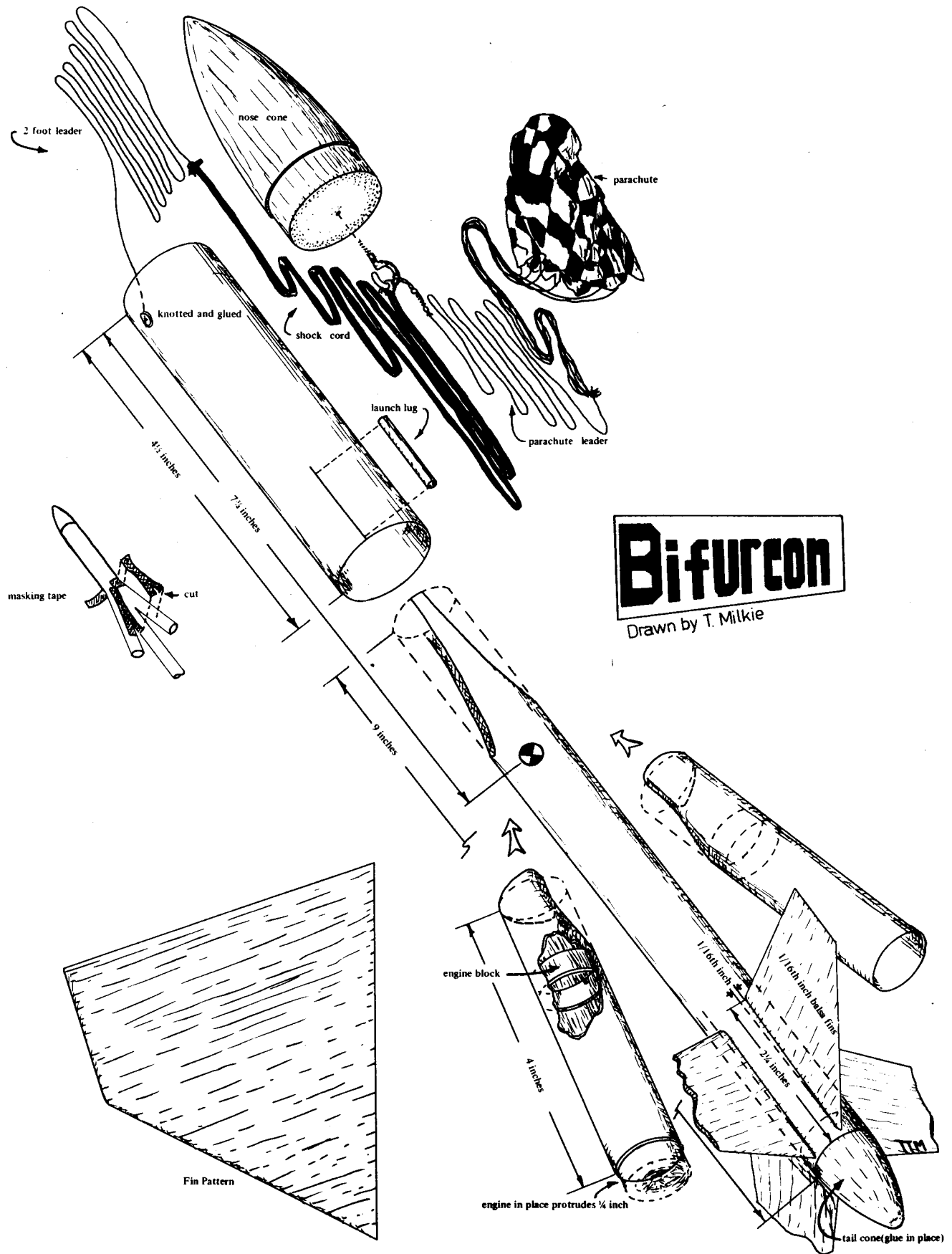

Are you launching more and enjoying it less? Do all your rockets look like the one the little kid down the street put together? Well, break out of that rut, and build the Bifurcon! This design employs side mounted engines canted outward from the body tube. With the engines far forward of the fins, stability is quite easy to establish. The position of the CG in the diagram is that for a loaded rocket built as described. No attempt was made to reach a maximum position for the CG (far forward), nor are the fins of optimum size for just adequate stability. Space for the recovery system is very generous, with the 1 inch diameter body tube, 4 inches long, at the top. These factors make this missile easy to assemble and launch.

If designed and developed for optimum efficiency, a bird of this configuration may prove superior to ordinary cluster engine methods. The upper body tube could, with a little more work, be formed of engine size body tube (Estes BT-20, Centuri No. 7, RDC G-18, Semroc B-2). It could also be shortened (or better yet, the engines could be raised on the tube). To find the optimum fin size, however, I have no suggestions other than trial and error. The effect of the branching body tubes on center of pressure location must be terribly difficult to determine.

Despite the "different" look of the Bifurcon, the engine placement on the side of the rocket is not something new under the sun. I believe Pat Artis once won a NARAM R & D competition with a design which placed 2 engines at the front of a rocket, parallel to the body tube.

The fins (four of them for the needed symmetry) are not placed 90 degrees apart. Instead, the angle between fins which straddle the exhaust gases from the engines is 120 degrees and the other two angles are 60 degrees. Experimentation with the .7 inch diameter engines (¼ A through C size engines) shows that the charring effect of the exhaust when it heats the rocket body or just deposits exhaust matter on the body tube) is effective in a cone of angle 27 degrees from the rear of the engine. This is a maximum figure, and in flight is undoubtedly smaller yet. The tail design and the separation angle of the engines (15 degrees from the aft fin body tube) is adequate to insure against damage to the fins or body tube caused by the engines. Test flights prove this fact out successfully.

### CONSTRUCTION

Cut the body tubes first. The aft body tube is 9 inches long and the engine tubes are each 4 inches long. These tubes are cut from .7 inch diameter body tube material. The forward tube is 4½ inches long and is cut from 1 inch diameter tube.

Cut out the two parabolic areas shown from one end of the aft body tube. A sharp knife is your best tool. The cutting is

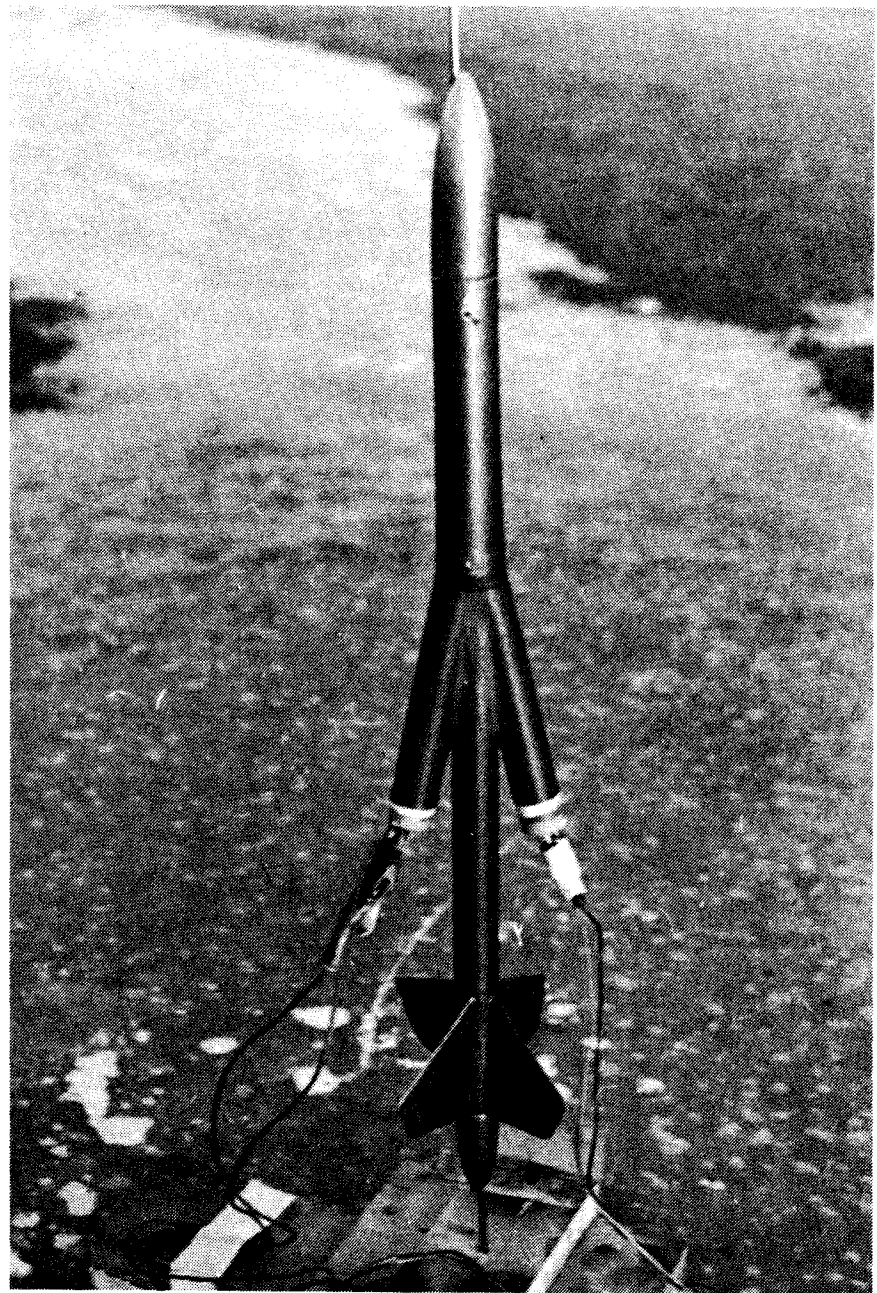

Photo by Steven Schuster

awkward, but it is not necessary to be exact. This cut will not show. It is a nice coincidence that when a 0.7 inch body tube is properly pinched, it will exactly take up ½ of a 1 inch body tube. (The area of a small body tube is  $\pi r^2$  or  $\pi$  times .49. The area of a large body tube is  $\pi$ ). If you believe this then it might be easier to cram the 2 engine tubes into the upper body tube, because you know it's possible. To prevent the entire tube from getting squeezed, it is advisable to stick an old engine casing in the engine tubes so that the end of the engine is just slightly outside the engine tube.

When you feel that the tubes are able to fit the larger tube, apply a generous supply of white glue around the inside of the forward tube, insert the engine tubes

about ¼ inch in and place this structure flat onto the angle alignment guide. By sighting along the side of the tubes, align all of the tubes for the appropriate angles to each other. Using lots of glue again, place the aft body tube in its place. The longest parts of the end of this tube should be the major gluing surface. These tabs should slightly overlap the engine tubes on top and bottom.

You may realize that because the larger and smaller tubes are attached together when both are lying flat on your table, the smaller tubes will not be placed exactly in the center of the larger tube or will be angled slightly out of the center. This is insignificant both in flight characteristics and esthetically.

Although it is not necessary, you may want to place the alignment guide on a

wooden surface and use pins beside the tubes to insure alignment. Weights may also be used.

While the body tubes are drying, cut and shape four fins using the fin guide, from 1/16th inch balsa. Apply any number of coats of sanding sealer to the shaped fins, nose cone, and tail cone, sanding between coats, until the desired finish is achieved.

Assemble a parachute and tie it to a leader. This in turn is tied to the screw eye in the nose cone, as is the shock cord. The other end of the shock cord is tied to a 2 foot length of string. When the body tube is ready punch a small hole in the top of the body tube 1/2 inch down from the top and pass this line through, from the inside out. Knot the string outside and glue the knot over the hole on the tube.

When the body tube structure is dry it should be fairly sturdy. Strength and improved looks are added by placing strips of masking tape along the joints as shown. Also wrap 2 layers of 1/2 inch tape around the joint between the engine tubes and the forward tube.

The fins are not spaced evenly around the body tube so use the fin marking guide to mark the tube. Remember! The smaller angle between fins (60 degrees) must be on the side between the engine tubes. Mark straight lines 2 1/4 inches long from these marks, then make another mark at the end of this line 1/16th inch around the tube. Now draw a new line between this mark and the first mark on the end of the tube. This is where the fins will be glued to produce spin. This corresponds to about 2 degrees for fin angle. Make sure all of your fins are angled in the same direction!

Glue on a launch lug so that it is on a side away from the engine tubes. It should be glued to the upper body tube, on top of the masking tape attaching the engine tubes. This is to allow adequate clearance for the launch rod, so that it won't bind.

Engine blocks in the engine tubes are needed to prevent inserting the engine too far into the tube and to help stiffen the "squashed" end of the tubes. Put a good amount of white glue into the tube and insert the engine block, using an engine casing. Place it so that engines will be completely inserted with 1/4 inch protruding.

Apply clear dope, especially over the masking tape, after sanding the body tubes with fine paper. Then finish the model to suit your tastes.

#### LAUNCHING

A design like that of the Bifurcon leads to some problems at launches. Two sets of leads, attached together in parallel, are needed to reach both engines. The wide fin separation helps in keeping the leads out of the way but care must still be taken when setting up. A good, strong battery supply is necessary, as with all cluster ignitions.

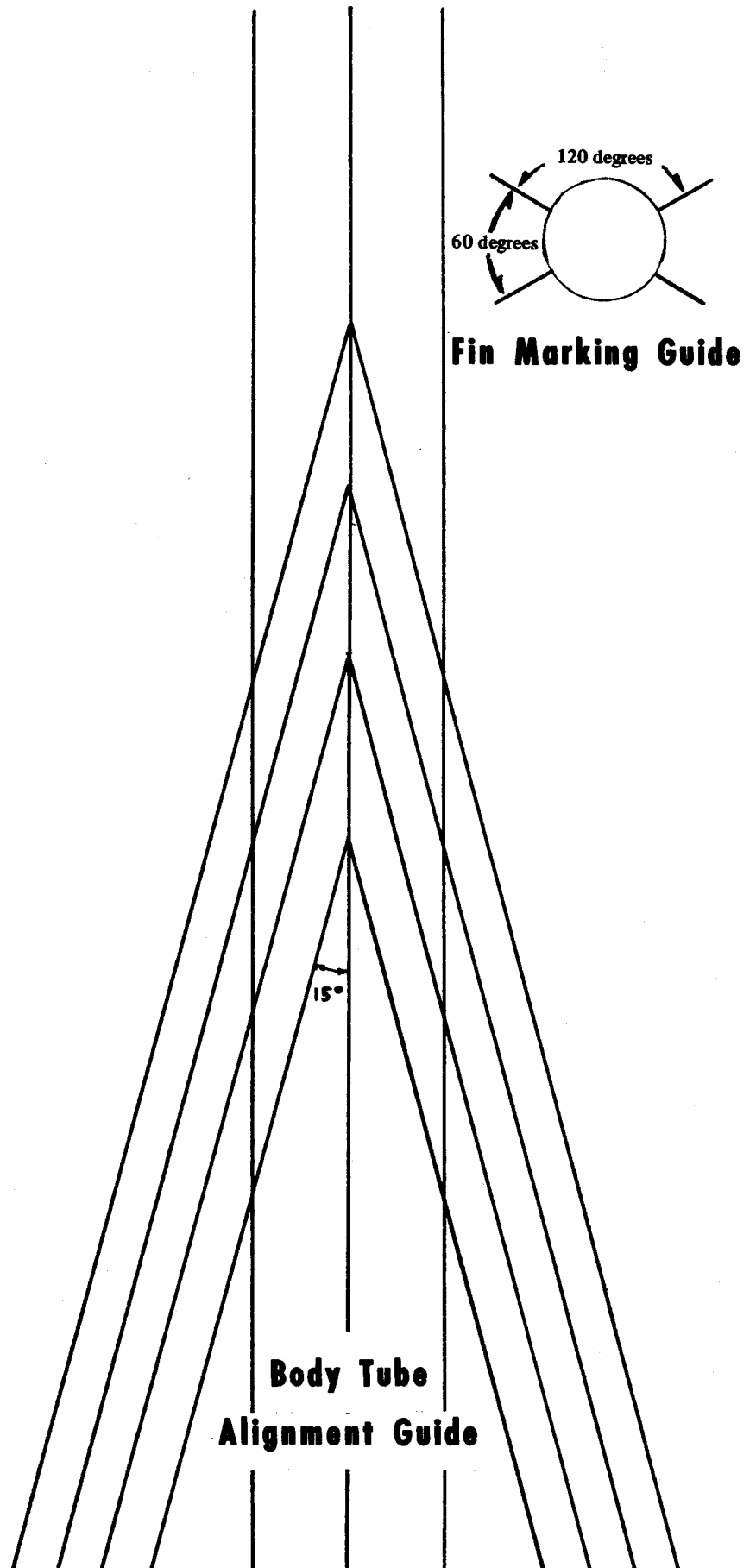

# Constructing a \$25

# Club Launch Panel

by Roger Golub

The Club Launching Panel, described in the January 1969 issue of *Model Rocketry* was a step forward in group model rocket launching. This design however has several drawbacks. First it is very expensive, a smaller club might not be able to afford one, second, the panel armed warning systems are lights. This could present a problem on bright sunny days, or to people working on the launch rack, some distance away from the panel. In this design a 12 position rotary switch takes the place of the 12 individual toggle switches with a considerable savings in cost. The second problem can be alleviated by using a "Sonalert" audible alarm module in place of the lights. This module delivers a loud whistling sound when the panel is armed. This whistle can be heard by spectators and anyone else in the vicinity. Since the Sonalert module is self contained it needs no speaker or amplifier, just have it connected to 6-28 volts DC. (This permits a wide range of battery voltages).

When you build this panel be sure to use very heavy wire to reduce the loss of power through cable resistance. Terminal Strip 1 (TS-1) is the battery input terminal. Be sure to observe correct polarity or the meter and the Sonalert will not work. M1 is a 0-30 amp DC meter. This is a change from the original circuit which used a voltmeter. An Ammeter is used because ignition depends on the amperage more than the voltage. Switches S1 and S2 are key lock

| Circuit Designation | Description                          | Allied Stock No. | Price     |
|---------------------|--------------------------------------|------------------|-----------|
| TS-1                | 2 Terminal Barrier Strip             | 47 C 1800        | .23       |
| TS-2,3              | 12 Terminal Barrier Strip            | 47 C 1806        | .89 each  |
| S1,2                | Lock Switch                          | 56 C 4156        | 1.94 each |
| S3                  | SPST Switch                          | 56 C 4250        | 1.37      |
| S4                  | Momentary Switch                     | 56 C 5028        | 1.75      |
| S5                  | 12 Position Rotary Switch            | 45 C 4351        | 1.02      |
| A1                  | Sonalert Module                      | 60 C 8983        | 5.50      |
| M1                  | 0-30 Amps DC Meter Type RF-2C        | 52 C 6047        | 2.60      |
|                     | Black Sloping Panel Cabinet<br>6x6x7 | 47 C 7467        | 4.40      |

## Parts List

Available From:  
**Allied Radio Corp.**  
 100 N. Western Ave.  
 Chicago, Illinois 60680

switches to prevent accidental arming of the panel. S3 is an on-off toggle switch. When this switch is closed the panel is armed and the Sonalert module sounds. S4 is the firing switch, when it is depressed the rocket engine should ignite. The area around S4 should be painted a bright yellow or orange to make sure it is not accidentally depressed. S5 is the 12 position rotary switch. This switch selects the launcher to

use. You will notice that with this set-up you can launch only one rocket at a time. There is generally no necessity to launch more than one at a time. To use the launcher take the lead from the positive buss with the corresponding lead from the negative buss and attach it to the igniter, arm the panel and launch! The panel is housed in a black sloping metal cabinet and can be assembled for about 25 dollars.

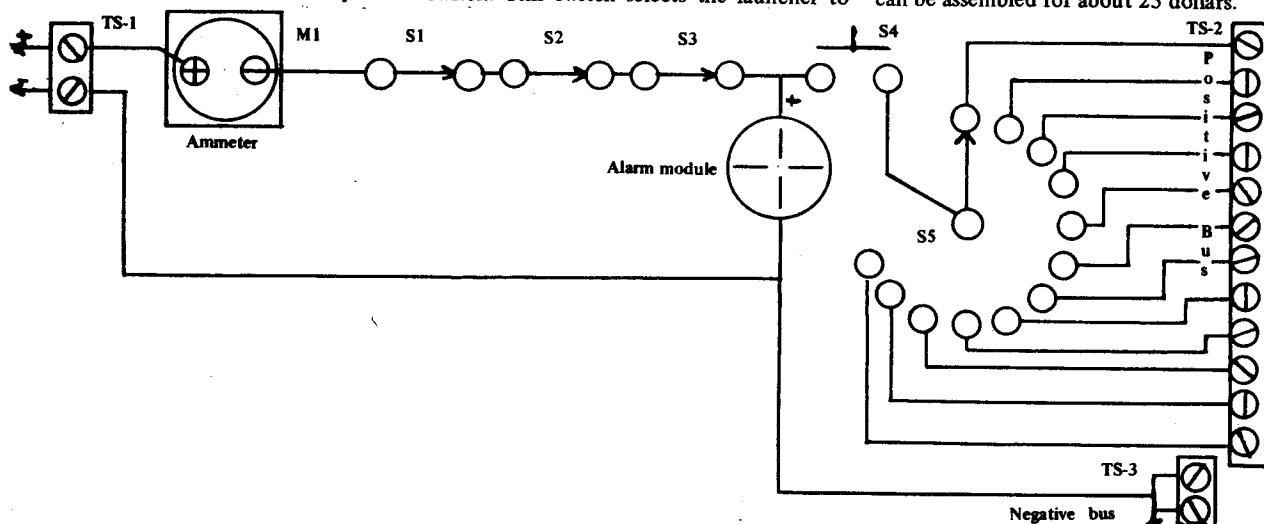

# How to Finish Model Rockets

by Thomas Milkie

What happens to your models after that last fin is glued on and it can stand up by itself? Does it go out to the launch site the next day, looking like pieces of balsa wood glued to a cardboard tube? If it does it may be hard to observe the rocket in the sky or find it on the ground. It will begin to look ugly after awhile and in any case, will not be kept on your trophy shelf. If it is a competition rocket, it will not fly as high as it would when properly finished, and it is more apt to become damaged.

## WHAT COLOR SHOULD YOU PAINT IT?

There are a complete rainbow of colors available today in spray enamel, lacquer, dope, brush bottles, and epoxy mixes. There are even some colors that aren't in the rainbow. Aside from the basic red, yellow, green, etc., there are also many colors designed for model cars and other flashy

paint jobs. Candy colors, pastel colors, way-out purples and greens, metallic colors, and metalflake paint are available. Many companies sell phosphorescent colors that really make your bird stand out from the grass after it lands. More conservative colors with a large selection are available in department stores, sold as auto touch-up paint or home repair paint in enamel and lacquer. Silver, gold, and other metal base paints are available in hardware stores. Some of these are flameproof to boot. Translucent colors and clear coatings can also be used on your modroc. To touch off that paint scheme a variety of decals (or decal sheets of colors, checks, etc.) and colored trim tape can be obtained at your local hobby store.

Don't let the large selection overwhelm you, though. Remember, your birds have to do something other than sit on a shelf and look impressive. Also, you can not mix lacquer, enamel, and dope without getting

into trouble. All white or blue rockets lose out big when the trackers try to find them in the sky. The same is true for green, brown, or black rockets on the ground. (Even with a bright streamer or chute, what happens when it is not fully deployed or comes off at ejection?) A few unfortunate fellows once decided that yellow was the ideal color, and bought a large supply of spray yellow enamel. Unfortunately, their launch site happened to be covered with yellow dandelions and made every rocket retrieval nearly impossible! Silver rockets are indistinguishable both in the air and on the ground. Heavy coats of metalflake and translucent enamel may look cool on plastic, but it can really keep an altitude rocket close to earth. Even with these restrictions, your rockets can still look good and operate well without painting them all red.

## WHAT MATERIALS TO USE

Besides the common finishing materials such as dope, enamel, and lacquer, there are other materials of use on model rockets. Hobby-poxy is an epoxy based paint that produces a tough, glossy finish with one coat. However, it must be mixed with a hardener before using, is messy to handle, and takes a long time to dry. Enamel dries faster, lacquer dries within an hour, and dope dries fastest of all. Drying time is important for many reasons. A slow drying material will bond stronger and will be easier to brush on. It will also make it difficult to handle the rocket, take a long time to apply the many coats necessary, and allow the rocket to attract dust while it is drying. If a slow drying paint is sprayed on too thick, it may also run. Another useful covering material is Super Monokote made by Top Flite for use on model airplanes (See

## ROCKET COVERING MATERIALS

| Material       | Advantages                                                                                        | Disadvantages                                                                                                                                                                                                        |
|----------------|---------------------------------------------------------------------------------------------------|----------------------------------------------------------------------------------------------------------------------------------------------------------------------------------------------------------------------|
| Dope           | Sprays on smooth but not glossy. Dries very fast. Covers nicely.                                  | Doesn't cling to slick body tubes well. Brushing leaves streaks. Can not be applied over enamel.                                                                                                                     |
| Enamel paint   | Many colors and types available. Sprays on glossy coat.                                           | Dries slowly, attracting dust. Stays slightly sticky for many days.                                                                                                                                                  |
| Lacquer        | Leaves a hard finish. Finish is high gloss.                                                       | Does not cover well, goes on thin in spray. Only spray recommended.                                                                                                                                                  |
| Epoxy paint    | Forms a very hard, glossy coat. Paint adds strength. Little undercoating needed. One coat covers. | Takes 24 hours to dry, shorter under heat lamp. Preparation and mixture is messy, takes 1 hour and all mixed must be used. Adequate ventilation is a necessity. Clean-up is messy. Paint and hardener are expensive. |
| Super Monokote | Very smooth finish covers imperfections. No prefinishing required. Adds strength to structure.    | Can not cover some structures. Must be cut and trimmed in sections. Expensive. Color choices limited.                                                                                                                |



Model Rocketry, January, 1969). This is a fine plastic that is ironed onto the rocket to produce a flawless finish. The cutting and ironing may be difficult on some models and the material is more expensive covering than any other, but no undercoating is required and the material adds strength. For a list of the advantages and disadvantages of each material see the comparison chart.

### SANDING AND UNDERCOAT

Even the best paint job will look terrible over a poor sanding and sealing operation. All balsawood surfaces should be fine sanded after rough sanding to the proper shape. Then apply a coat of sanding sealer or balsa fillercoat, available in most hobby shops. This substance will fill the pores in the wood grain and provide a smooth finish. When the sealer is dry, sand with fine sandpaper and apply more sealer. The greater the number of coats the less grain will show up in the final paint job. But don't go insane applying 20 coats and sanding each coat off with sandpaper! If you are out of sealer a sealing job can be done by rubbing talcum powder into the grain. Blow off any excess and then begin applying your finishing material.

Most glossy body tubes will not hold dope very well. If you are using dope, the tube should first be fine sanded to improve the adhesion of the finish. Then coat the entire rocket with one or more coats of clear dope.

### HOW TO FINISH MODEL ROCKETS

A single color paint job may be cheap and easy to apply, but the work involved in making a color scheme is worth the effort.

A dark or bright color covering most of the rocket and trim in white or yellow often looks nice. The trim may be paint or plastic trim tape. Another good type of color scheme is that stressed by art teachers ever since they discovered color: use any color and the color opposite it on a color wheel (this is called a complementary color scheme). In most cases you can really improve on this by separating the colors with a *fine* line of white (or yellow if it is appropriate). Unless you are really going to go psychedelic, it is not advisable to use more than 2 colors and possibly a little white or yellow.

If you are going to use more than one color, apply the lightest one first, just slopping it on. Let it dry completely then mask it over along the exact line of separation between the colors. Now apply the next lightest color, then mask off for the last color. When applying masking tape, every inch of the tape has to be tightly pressed down to make a complete seal for the paint. Run your thumbnail down the edge of the tape, then coat this edge with clear dope (if you are coating with dope). If you have some plastic trim tape of about 1/8th inch thickness, this may be used in place of the masking tape, since it can turn tight corners and seals nicely. If you are afraid of painting over this tape, or if you are spraying, you may want to apply masking tape over it. When removing any tape from painted surfaces, always pull the tape back against itself, slowly so as not to take the surface with it. *Do not* pull tape up at 90 degrees to the surface.

Spray paint, although it is more expensive than brush paint, gives a much better paint job. For best results follow this really wild trick: Read the label! Some materials cannot be obtained in spray cans. If you want a really good paint job with a little

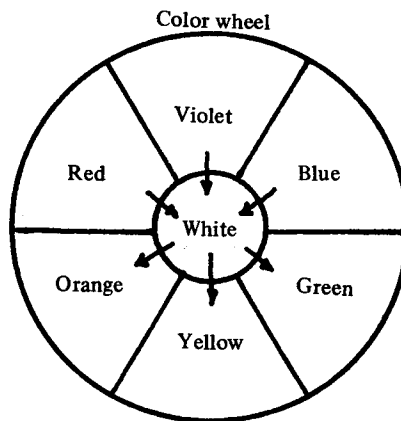

**2 colors opposite each other make a good color scheme.**

effort these materials can be thinned down and sprayed with an air brush. To handle a modrock while spraying, tape 2 engine casings together in line and make a tight fit in the rocket tube. To hold the rocket when drying, a dowel or wire held down on a shelf with weights can be stuck into the engine casings, so that the rocket is suspended over the edge of the shelf.

Government insignia and rocket instruction wording may be applied in decal form. Other, more flashy decals are available from model airplane suppliers or your hobby shop. National Association of Rocketry decals are available to members through NAR Technical Services. To apply your NAR number, club name, etc. it is very easy to use dry transfer type decals, available in stationery stores. Sold in sheets of letters and numbers of any size, these transfers need only be rubbed on one side to transfer the image onto your rocket. When everything has been applied it is a good idea to coat the entire rocket with a clear spray of lacquer or plastic spray.

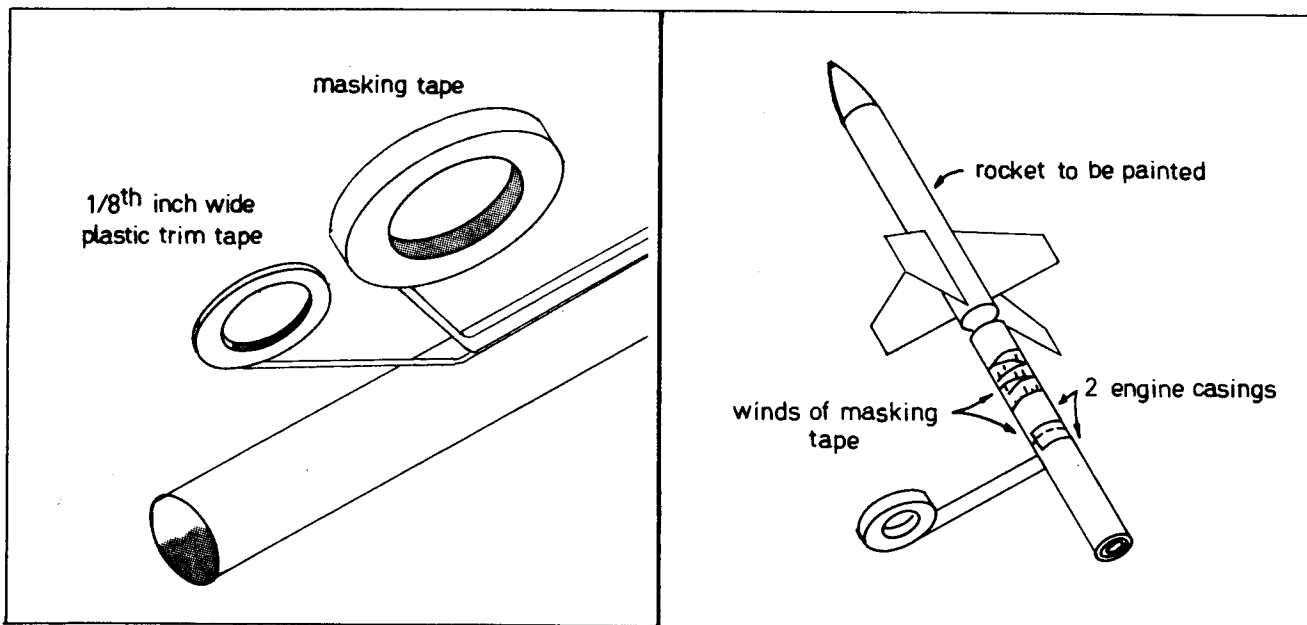

Use of thin plastic tape for masking.

Engine casings are useful for holding the rocket when spray painting.

**Scale Design:**

# Genie (M3-1)

## Air-to-Air Rocket

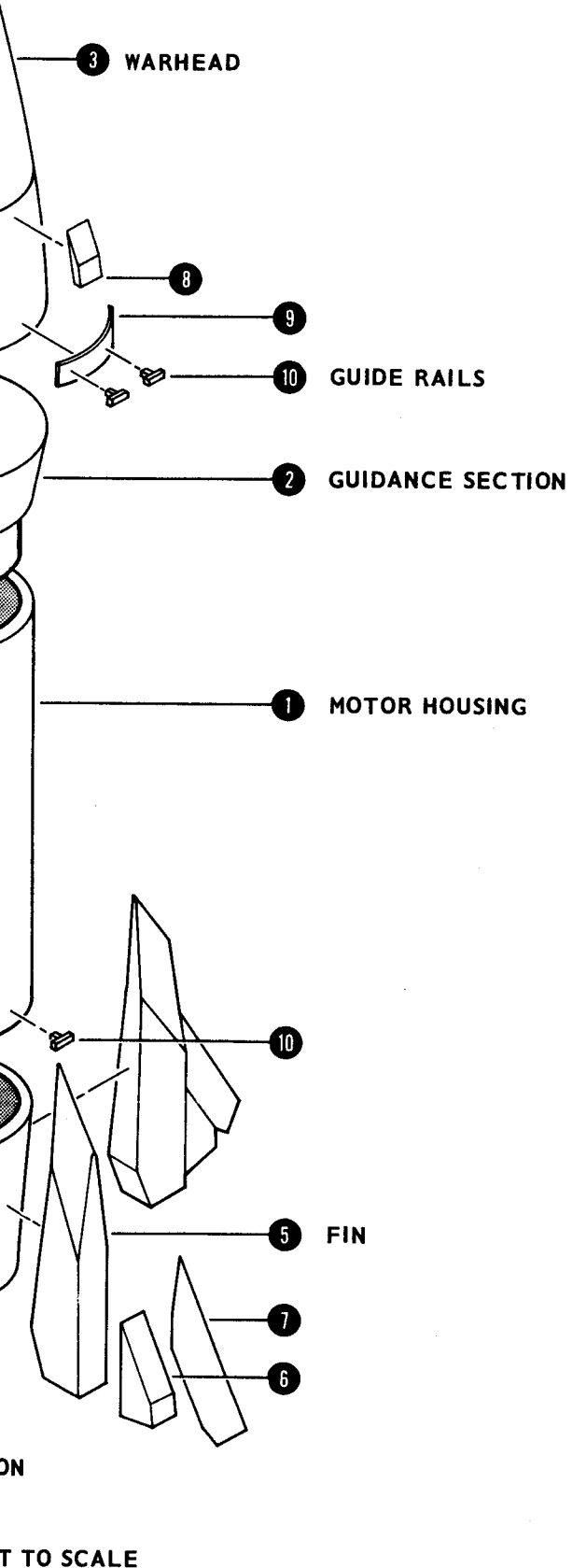

Development of the Ding-Dong (later renamed High Card and eventually called Genie) began at the Air Research and Development Command of the USAF in early 1955. The Douglas Aircraft Company was given prime responsibility for construction of the single stage, air-to-air, interception missile. Design of the airframe awaited successful development of a nuclear warhead by the Los Alamos Scientific Laboratory. The solid fuel engine, fabricated by Aerojet-General, propels the 800 pound missile over 6 miles.

On July 19, 1957, the Genie became the first US air-to-air missile to carry a nuclear warhead. The Genie was launched from an F-89J Scorpion over Yucca Flats, Nevada during *Operation Plumbob*. To demonstrate that there was no danger of fall-out from the nuclear explosion, five USAF officers stood under the blast (which occurred at high altitude).

Genie is an unguided weapon with four swept wings to give it aerodynamic stability. Cost of the rocket is \$7000 plus \$243,000 for the nuclear warhead. In practice firings, a primary hit is considered if the missile comes within 500 feet of the target, an approach to within 1000 feet is considered a secondary hit.

Initial deployment of the missile took place in 1958. Genie is carried on F-89, F-101, and F-106 fighters of the Air Defense Command, the Tactical Air Command, and the European and Pacific Commands. The Genie's mission is to 'intercept and destroy' incoming enemy bombers before they reach their targets.

To make the Genie requires turning the nose and tail cones from solid balsa or hardwood blocks since no commercial cones are available. The rocket is white except for detail indicated on the plans which is glossy black.

- 1 1" x 2 15/16" Hollow Balsa Block
- 2 1" x 1 1/4" Square Balsa Block
- 3 3 1/2" x 1 1/4" Square Balsa Block
- 4 1 3/16" x 1" Square Balsa Block
- 5 9" x 5/16" x 1/4" Balsa Strip
- 6 3" x 5/16" x 1/4" Balsa Strip
- 7 6" x 3/16" x 5/16" Balsa Strip
- 8 1" x 1/8" x 1/16" Balsa Strip
- 9 1" x 1/8" x 1/32" Balsa Strip
- 10 1" x 1/16" Square Balsa S

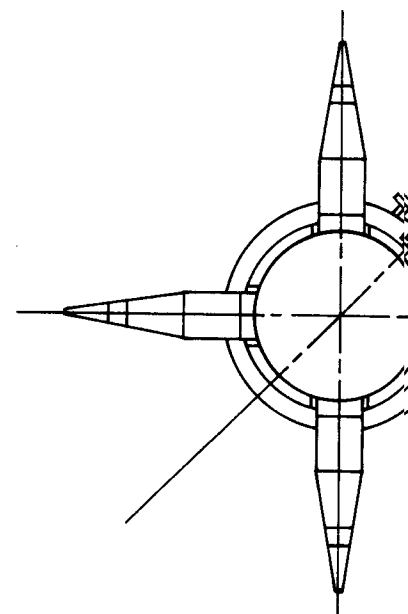

DRAWN TO SCALE

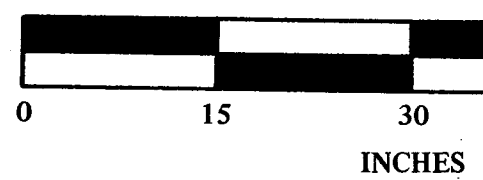

**Genie Specifications**  
Single-stage, solid-fuel, air-to-air

- Length: 101 inches
- Diameter: 15 inches maximum
- Weight: about 800 pounds
- Guidance: free flight
- Range: 6 miles
- Warhead: nuclear or conventional

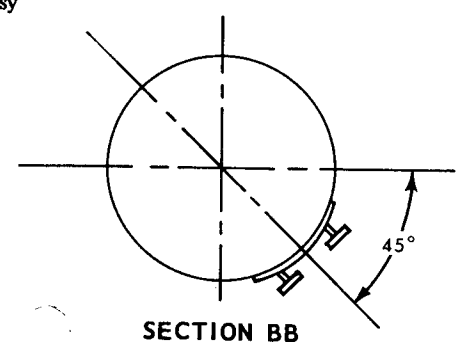

DRAWN TO SCALE



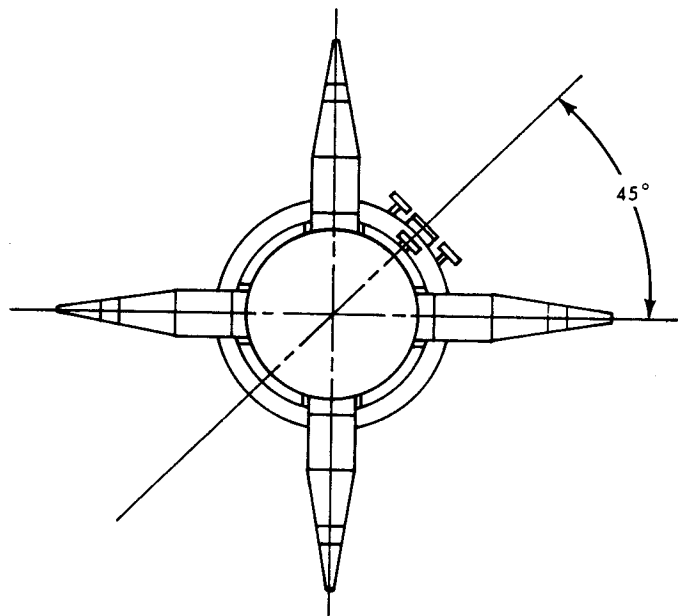

DRAWN TO SCALE



INCHES

### Genie Specifications

Single-stage, solid-fuel, air-to-air interceptor rocket.

- Length: 101 inches
- Diameter: 15 inches maximum
- Weight: about 800 pounds
- Guidance: free flight
- Range: 6 miles
- Warhead: nuclear or conventional

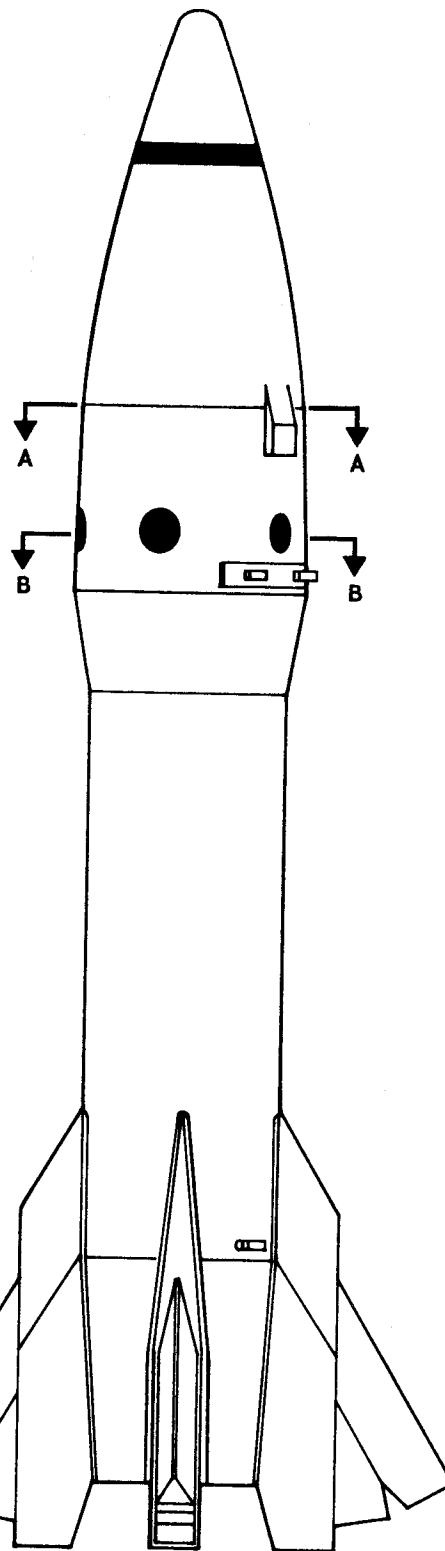

SECTION AA

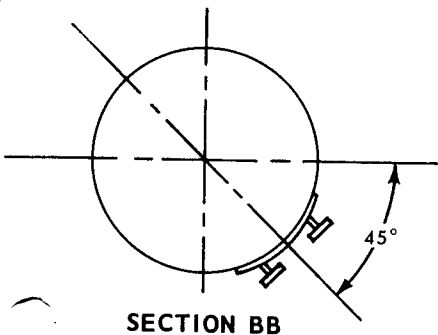

SECTION BB

All scale data supplied by the Missile and Space Division of the Douglas Aircraft Company.

Only \$1.00

This full color reproduction, 8½ by 22 inches in size, and suitable for framing can be yours for only \$1.00 (or 6 for \$5.00), plus 25 cents for postage from:

**ASTRO PHOTOS**  
2278 West 6th Street  
Brooklyn, New York

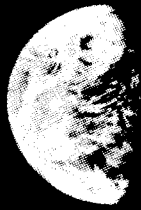

**Limited Supply!**

**Order Your Copy Now!**

**ASTRO PHOTOS**  
2278 West 6th Street  
Brooklyn, New York

*Full Color Photo*

*Taken by*

*APOLLO 8 Astronauts*

This spectacular view of the rising earth greeted the Apollo 8 astronauts as they came from behind the moon after the lunar orbit insertion burn. The surface features visible on the moon are near the eastern limb of the moon as viewed from the earth. The lunar horizon is approximately 780 kilometers from the spacecraft. The width of the area photographed is about 175 kilometers at the horizon. On the earth, 240,000 miles away, the sunset terminator bisects Africa.

# Reader Design Page

Each month Model Rocketry will award a \$5.00 prize for the best original rocket design submitted by a reader during the preceding month. To be eligible for this prize, entries must be suitable for offset reproduction. They should be carefully drawn in black ink on a single sheet of 8½ by 11 paper. Sufficient information should be contained in the drawing so that the rocket can be constructed without any additional information.

Submit entries to:  
**Rocket Design**  
**Model Rocketry**  
 Box 214  
 Boston, Mass., 02123

This month's design is a two-stage parachute recovery rocket submitted by Bill Colburn of Canterbury, New Hampshire. The Venus I has a payload compartment which has carried up to one ounce of payload. The large booster fins and pods on the fins mean that these should be glued well to prevent a disaster in the air. For the same reason, do not attempt to launch this bird with any series 2 engines (such as a B14-0 in the lower stage).

The pods are made from lengths of the plastic tubing available from Estes Industries. To fasten the fin tips to the pods (2 on each fin), Bill suggests gluing the tips to paper tape strips and sticking these onto the pods. Remember when installing the engine block in the upper stage to allow the engine to extend about 1 centimeter below the body tube. This is so that the booster tube can slip over the first stage engine.

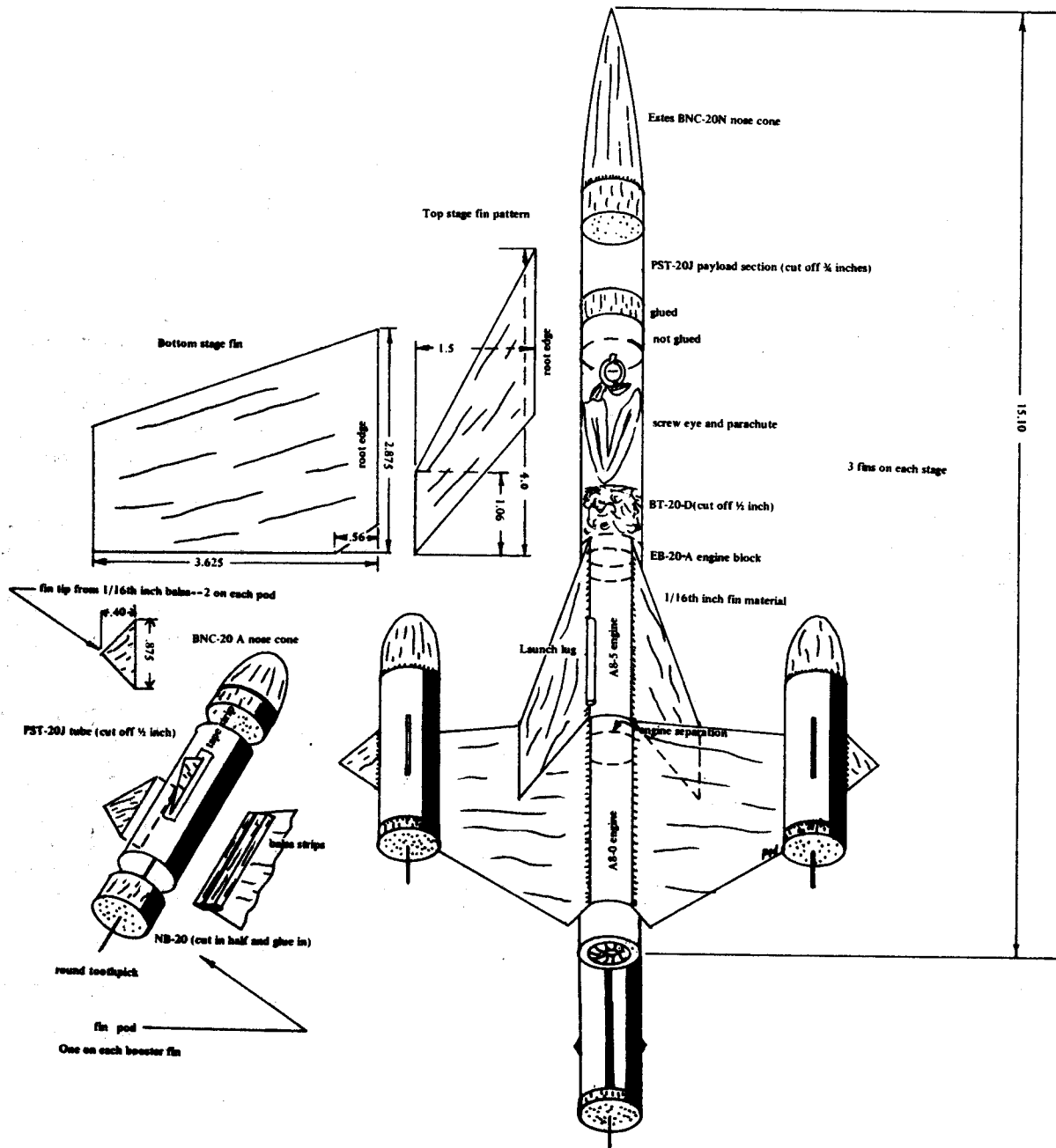

# MODEL ROCKETRY

## DON'T MISS OUT

DON'T MISS OUT on any issues of the new **Model Rocketry** magazine – the only magazine for model rocketeers. Keep in touch with the rapidly expanding hobby-science of model rocketry. Read the latest news on NAR activities – local, regional, and national meets – construction plans –  
– scale info – new materials and methods –  
– maps for rocket design – section news –  
– special features – and more!\*\*\*\*\* **SUBSCRIBE TODAY!**

**Model Rocketry**  
Box 214  
Boston, Mass, 02123

Special Club Rate with 10 or more subscriptions – \$2.75.  
Have your section subscribe!

Please send me (check one):  The next 6 issues \$2.00  
 The next 12 issues \$3.50

Name \_\_\_\_\_  
Street \_\_\_\_\_  
City \_\_\_\_\_  
State \_\_\_\_\_ Zip Code \_\_\_\_\_

# q & a

In your November issue of *MODEL ROCKETRY* in the article on extensible flexwing rockets you mentioned a wind tunnel test program carried out on some models. I was very interested in what type of lift and drag balances you used. I could hardly gather any information from the pictures in the article, and I would appreciate any information you could send me on the balance and the wind tunnel.

Richard Pattis  
Wilmette, Ill.

The wind tunnel and balance system you refer to was built during the winter of 1964-1965 by me in Great Neck, New York and is presently stored in somewhat modified form in Melville, New York.

The wind tunnel itself is a single-return flow type featuring octagonal corners rather than the common quadrilateral type. This arrangement was adopted in order to make possible the operation of sheet-metal corner vanes formed directly on a break rather than given a more complicated airfoiled shape. By a single-return design, I mean that the air is made to flow continuously around a closed circuit rather than being merely taken in through a contracted entry channel, driven through the test section (at the bottom of this particular tunnel). The pressure of the air is made to increase as it passes through the rapidly-revolving fan, from whence it travels through a diffuser to a stilling chamber, a section of the tunnel having a greater cross-sectional area than the test section. The stilling chamber is the left-hand portion of the tunnel as it appears in the photographs, and has a square cross-section of 20 by 20 inches (internal dimensions). From the stilling chamber the air travels through an entry contraction, in which its increased pressure is converted to increased velocity, and through the test section (the area having a plexiglass window) at a high rate of speed. Thereafter it is expanded to low velocity again in a diffuser (at the right portion of photo) which brings it back again to the fan. The fan must continuously raise the pressure of the flow passing through it because of losses due to viscous effects incurred by the air as it travels the closed circuit.

The purpose of the stilling chamber is to reduce the turbulence in the test section. The larger the stilling chamber in relation to the test section, the more efficiently this is accomplished. That the wind tunnel used in these experiments had a ratio of cross-sectional area in the stilling chamber to cross-sectional area in the test section of only 4.17 to 1 was due entirely to structural

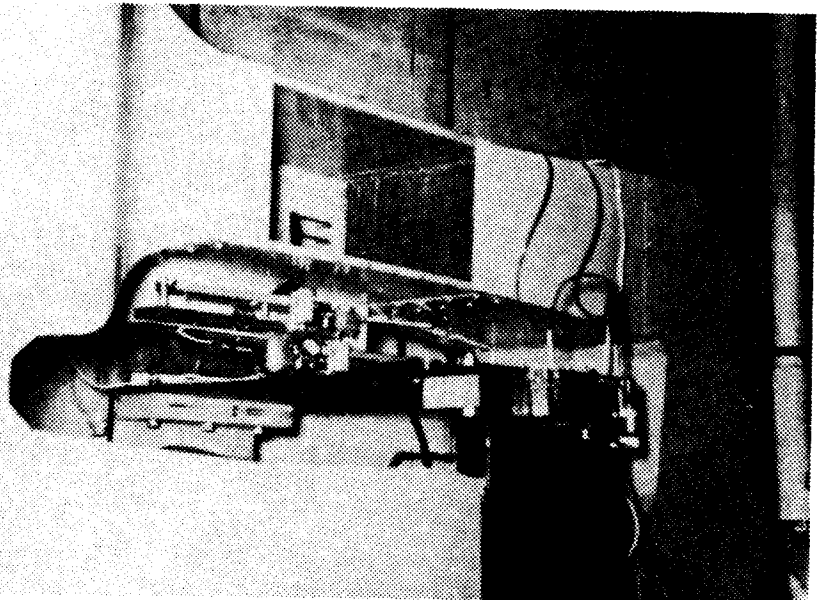

and space limitations; in general, the larger this ratio can be made, the better.

You may also notice that there are sheet-metal 'honeycombs' at the forward and after sections of the test section. These have since been removed and replaced with a honeycomb composed of 7600 jumbo soda straws at the interface between the stilling chamber and the entry contraction, this being a more efficient arrangement. There are also screens in the stilling chamber, which help to reduce the turbulence.

The balances used for these experiments were basically beam balances having coarse scales operated by manually sliding a unit weight from one detented slot to another, and fine scales consisting of threaded brass rods. The rods were turned by small electric motors. Since the tapped holes in the weights were made at their upper ends, the weights tended to hang from the rods and remain vertical when the rods were turned. The resulting action would drive the weights this way or that, depending on which way the DC motor was turning. This, in turn, was controlled by 'reversing studs' at the pointer end of the balance, making its operation as follows: suppose a positive lift has been applied by a test wing to the lift balance, and that the coarse scale has been adjusted to bring the adjustment of the reading within the limits of operation of the fine scale. The electrically-conducting pointer at the other end of the balance beam is now touching the stud such that the current flowing in the motor drives the travelling weight out along the beam. It finally drives it too far, such that the beam tips down and the stud of opposite polarity is contacted. This drives the travelling weight back again, etc. Soon a position of equilibrium is reached in which the conducting pointer rests in mid-air, in the small gap between the oppositely-polarized studs. The balance is now fully adjusted and has automatically given you your 'fine' component of the lift reading, just as the sliding

weight on a laboratory beam balance reads that portion of an object's mass which is expressible in grams or tenths of grams.

In my particular arrangement the drag balance rested on a platform on top of the lift balance. This is not a good idea, however, since it places the center of gravity of the lift pivot system above the pivot axis itself, and thus makes the lift balance be forever 'ticking' back and forth to control the unstable arrangement. I would suggest, if you plan to build such a unit, that you position the drag balance base in a platform below the lift pivot axis.

Something you might want to do, if you are interested in wind tunnels and balances in general, is to look through a copy of *Wind Tunnel Testing*, an excellent book on the subject written by Alan Pope, an experienced experimental aerodynamicist. The book is published by John Wiley and Sons, Inc., of New York and should be obtainable in most college book stores. You are probably better off to obtain a used copy of the first or second edition, as this will mean a lower price and also that the material is more oriented toward the low-speed techniques of greatest use to the model rocketeer. Mr. Pope's book also contains a great many diagrams which should be of considerable help in interpreting the things I have described.

I hope these brief descriptions have been of some use to you. If you have further questions, please don't hesitate to write us again.

- G M

*Any questions submitted to this column and accompanied by a self-addressed, stamped envelope will be personally answered. Questions of general interest will also be answered through this column. All questions should be submitted to:*

*Q and A*

*Model Rocketry Magazine  
Box 214  
Boston, Mass. 02123*



# DYNAFLORA

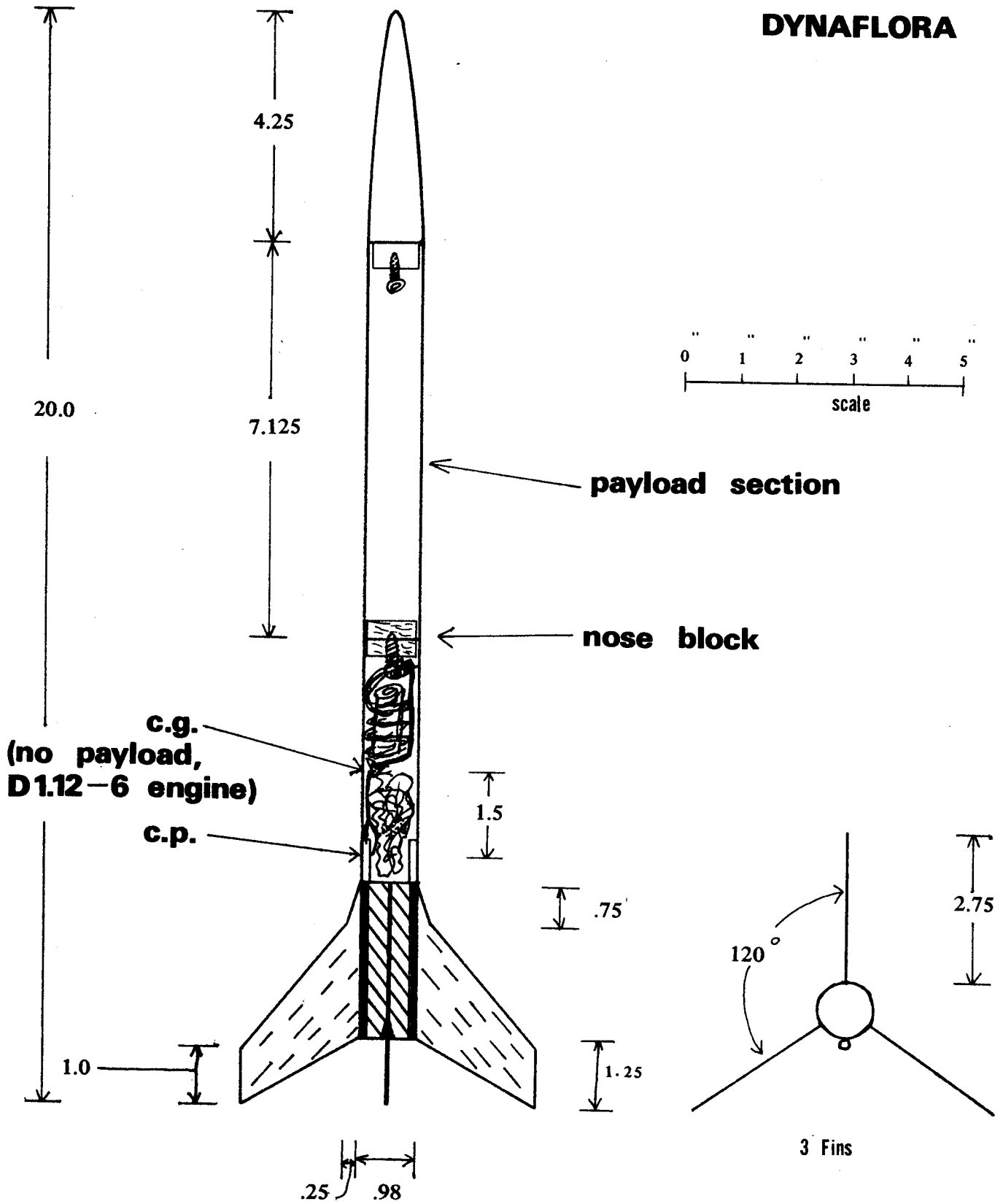

(ALL DIMENSIONS IN INCHES)

# The DYNAFLORA

## Single Stage Sport and Payload Rocket

by George Caporaso

The Dynaflora is an aesthetically pleasing, single-stage sport and payload rocket designed to be flown with class A through E engines. It is simple to build and uses standard length body tubes.

With a length to diameter ratio of 19.3, its dynamic stability is excellent. The parabolic nose cone minimizes pressure drag while the low area, 3-fin design minimizes interference and friction drag on the fins. The construction plans do not take into account the optimized weight, which varies with the type engine. The optimum weight for each engine can be determined from Centuri's *TIR-100, Model Rocket Altitude Performance*. The payload weight can then be adjusted accordingly or additional nose weights can be added to the nose cone as desired.

In the accompanying diagram, one 12 inch parachute which brings down both the booster section and the payload section is shown. The author has found that if a payload of several ounces or more is used, it is best to use separate parachutes for the payload and booster sections as he has had occasion to glue many mangled fins back on the booster when using a payload of only 1.5 ounces. For normal flying, without a payload, one 12 inch parachute should be adequate.

Because of the somewhat spectacular altitudes achieved by this rocket using FSI D or E engines, it is not advisable to launch it in even moderate winds as it goes out of the launch area quite easily with only a 12 inch parachute. A smaller parachute would most likely result in damage to the fins, so it should be launched in good conditions only.

The engine block assembly will vary depending on what type of engines you plan on flying the DYNAFLORA with. Estes' A through C type engines will require that company's 651-EH-2050 engine mounting kit while two different mounts will be required depending on which Flight Systems engines are used. For FSI B through D types, a hollowed out Estes nose block (651-NB-50) can be used for the forward bulkhead spaced 2.75 inches from the rear of the tube. For an FSI E engine the same bulkhead can be used but it must be glued to the body 3.75 inches from the rear of the tube. In either case, three small strips of balsa should be cut which will run the length of the engine in question. These should be glued at 120 degree angles to the inside of the booster tube, from the rear of

the tube right up to the forward bulkhead so that the engine will make a snug fit in the tube (the tube is .95 inches I.D. while the FSI engines are .83 inches O.D.).

To begin construction, decide on which class of engine you will use to power the DYNAFLORA, and construct the appropriate booster section, or build several interchangeable sections if it's desired to fly it with different engines classes.

Next, assemble the payload compartment. Glue the solid nose block half way into the payload tube. Insert a small screw eye whose threads are covered with white glue into the bottom of the exposed nose block.

Tie one end of a thin shock cord to the screw eye. Glue the other end of the shock cord onto a 2.5 inch by 1.0 inch piece of paper (width-wise), and repeatedly fold over the paper width wise into a final strip 2.5 inches long by .25 inches wide. Now bend this strip in the shape of a ring, apply glue to the outside of it, and place it into the body tube just above the engine bulkhead. Next, assemble a 12 inch parachute and fasten the ends of the shroud lines to a fishing leader clip so that the parachute may easily be removed from the screw eye.

Lastly, glue a launching lug to the rocket at or near to its center of gravity (which is marked on the drawing for a D 1.12-6 engine). Now the rocket is ready for finishing.

The DYNAFLORA looks extremely

sleek and impressive if painted all one color; black for example. However, if it is desired to paint it in a different manner, a white base coat of spray dope should be applied all over the rocket after the balsa fins and nose cone have been appropriately sanded and shaped. In addition, the spiral wound body tubes should be sanded with extra fine or fine sand paper since dope does not adhere well to an unsanded spiral wound tube. The balsa should be sealed with Aero-Gloss Balsa Fillercoat or Testors Sanding Sealer, and suitably sanded.

The various colours can now be added. If possible, the rocket should be spray painted with dope. As usual, the most important areas on the rocket from the point of view of minimizing the drag, the areas requiring the smoothest surfaces are the nose cone, nosecone-body tube joint, the entire fin surfaces and the fin-body tube joints. A filler of white glue should be smeared across each fin joint prior to painting to reduce interference drag.

The DYNAFLORA has spectacular flights with C,D and E engines. Because of its relatively large size, it can be seen throughout the flight with the long burning engines.

### PARTS LIST

|               |       |             |
|---------------|-------|-------------|
| Booster Tube  | Estes | 651-BT-50H  |
| Payload Tube  | Estes | 651-BT-50H  |
| Nosecone      | Estes | 651-BNC-50Y |
| Fin Stock     | Estes | 651-BFS-20  |
| Engine Blocks | Estes | 651-NB-50   |
| Engine Mounts | Estes | 651-EH-2050 |
| Parachute     | Estes | 651-PK-12   |
| Shock Cord    | Estes | 671-SC-1    |
| Screw Eye     | Estes | 651-SE-2    |
| Launch Lug    | Estes | 651-LL-2B   |
| Engines       | Estes | B.8-6       |
|               | FSI   | C 1.75-6    |
|               | FSI   | D 1.12-6    |

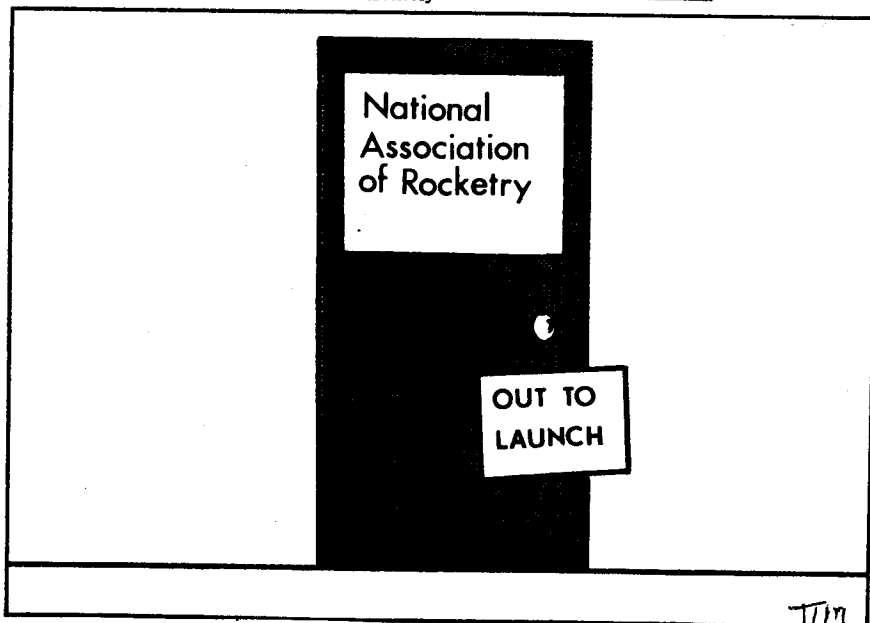

# PHOTO GALLERY

*Readers are invited to submit photographs of their model rockets for publication on this page. Our staff will select those photographs having superior quality and composition for inclusion in the Model Rocketry Photo Gallery. Send your photos to:*

*Photo Gallery  
Model Rocketry  
Box 214  
Boston, Mass. 02123*

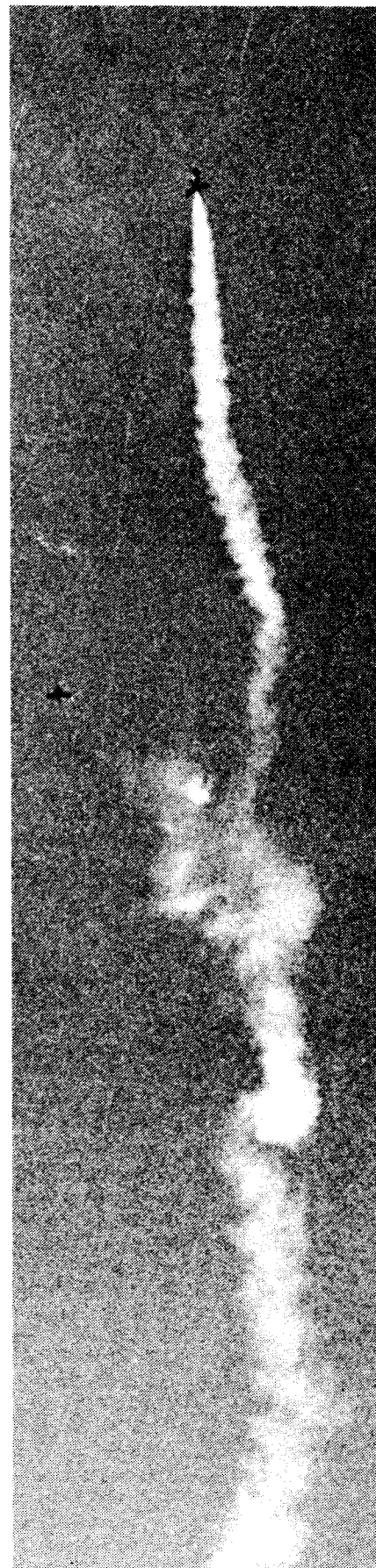

# Fundamentals of Dynamic Stability

Gordon K. Mandell

In this issue of *Model Rocketry* we conclude our series on model rocket dynamics with a discussion of the principles of sound model design. Past installments have featured the mathematical relationships by which the rotational movements of a model rocket subjected to in-flight disturbances of various kinds can be calculated (Parts I and II), theoretical methods for calculating the aerodynamic moments and inertial characteristics on which the dynamic responses depend (Part III), and experimental techniques by which the aerodynamic and inertial properties of a given model can be determined and compared with the predictions of theory (Part IV).

If this were all we wished to do, however—to analyze, to calculate, to measure—the lengthy expositions of the past four months would be of little value to the model rocketeer. The true purpose and the real value of engineering analysis is that it enables the formulation of rational rules for the *design* of devices and systems subject to its scrutiny. It is this purpose we wish to fulfill in this month's discussion.

## PART V

### DYNAMICAL CONSIDERATIONS IN MODEL ROCKET DESIGN

We found, in our analytical considerations of the dynamic behavior of model rockets, that the characteristics of importance in determining dynamic response were the five "dynamic parameters:"

- $C_1$ , the corrective moment coefficient
- $C_2$ , the damping moment coefficient
- $I_L$ , the longitudinal moment of inertia
- $I_R$ , the radial moment of inertia
- $\omega_Z$ , the roll rate

We discovered, moreover, that these quantities "fit together" to form certain fundamental relationships which characterize the behavior of any given rocket. Among the most important of these relationships are:

$\sqrt{\frac{C_1}{I_L}} = \omega_n$ , the natural frequency of a rocket whose roll rate is zero;

$\frac{C_2}{2\sqrt{C_1 I_L}} = \zeta$ , the damping ratio of a rocket whose roll rate is zero;

$\frac{I_R \omega_Z}{I_L}$ , the gyroscopic precessional frequency of a rocket which is rolling and subjected to no aerodynamic moments;

$\sqrt{\frac{C_1}{I_L + I_R}} = \omega_{nc}$ , the "coupled natural frequency" of a rolling rocket subjected to sinusoidal forcing at the roll rate;

$\frac{C_2}{2\sqrt{C_1(I_L + I_R)}} = \zeta_c$ , the "coupled damping ratio" of a rolling rocket subjected to sinusoidal forcing at the roll rate.

In designing a model rocket for favorable dynamic behavior, we have to consider not only the values of the individual dynamic parameters, but also these relationships among them. To "design" a rocket, from the standpoint of dynamics, is to adjust its shape and mass distribution so as to produce values of the dynamic parameters which give rise to favorable characteristics in its dynamic response. "Favorable characteristics," in turn, mean that:

(a) The rocket is not easily disturbed, or deflected from its intended direction of flight. For a given disturbing influence, the angle through which it rotates is small.

(b) The rocket soon returns to face the intended direction of flight once the disturbance has passed, and does so in an oscillatory fashion so that the effect of the disturbance is evenly distributed about the intended flight axis.

### REPRESENTATIVE PARAMETERS

Before we delve into a discussion of

what dynamic characteristics a model rocket *ought* to have, we had better take a look at what values a reasonable model *can* have—to avoid going off the analytical deep end and requiring the impossible! A big step in this direction, in turn, is to find out what values a *typical* rocket has, for the range of possibility can generally be expected to extend a given distance either side of the "average" rocket.

For this purpose the typical model rocket configuration DTV-1, illustrated in Figure 1, was constructed and tested according to the methods of Part IV in the low-turbulence wind tunnel of the Massachusetts Institute of Technology's Aeronautical Projects Laboratory. DTV-1 was found to have the following dynamic parameters:

$C_1 = 0.65V^2$  dyne-centimeters, where  $V$  is given in centimeters per second

$C_2 = 10.5V$  dyne-centimeter-seconds

$I_L = 9100$  gram-centimeters<sup>2</sup>

$I_R = 178$  gram-centimeters<sup>2</sup>

The roll rate was an independent variable determined by the speed of the roll motor on the balance system (see *Model Rocketry*, February 1969, for a description of this apparatus,) which is shown in Plate 1. From the above quantities we can obtain:

$\omega_n = .00845V$

$\zeta = .0682$

$\frac{I_R \omega_Z}{I_L} = .0195 \omega_Z$

$\omega_{nc} = .00838V$

$\zeta_c = .0675$

where  $V$ , the airspeed, is given in centimeters per second and  $\omega_Z$  in radians per second. Now it is probable that DTV-1 is

not precisely in the center of the "average" range as model rockets go—it is rather on the heavy side and has a static stability margin of three calibers (that is, the center of pressure is three body diameters aft of the center of gravity). Nevertheless, it is undoubtedly representative enough to allow the following general statements to be made:

(1) In a model rocket of average design, the damping ratio tends to be low—on the order of one tenth. Resonance, when it occurs, tends to be a problem and will usually be caused by the development of a roll rate whose value is close to the natural frequency. Overdamping, on the other hand, is much less common and not usually to be feared.

(2) The radial moment of inertia is very slight compared to the longitudinal moment of inertia—on the order of a few percent. The roll rate must be very rapid to produce appreciable gyroscopic moments. Therefore, the angular frequencies and rate of decay of the response of an average model rocket subjected to transient disturbances while spinning about its longitudinal axis are very nearly equal to those that would describe the behavior of the same rocket if it were not spinning at all, unless the spin is very fast. By "very fast" we mean that the gyroscopic precessional frequency is, say, 10 percent or more of the natural frequency. For DTV-1 during powered flight this would mean a spin rate on the order of 100 radians (about 16 revolutions) per second.

(3) As another consequence of the small radial moment of inertia, the resonance condition for a given rocket is nearly the same when it is rolling as when it is not; i.e., the natural frequency is nearly equal to the *coupled* natural frequency and the damping ratio is nearly equal to the *coupled* damping ratio. This is an advantage in that the presence of roll does not appreciably increase the severity of the resonance.

### THE EFFECTS OF VARYING THE PARAMETERS

Having established the "average" or "representative" dynamic characteristics, we can start to think about what happens when we depart from the average in various ways. We must remember, when doing this, to take into account factors affecting the trajectory of the rocket and its altitude performance (such as overall weight) as well as those affecting its rigid body dynamics.

First, consider the effect of increasing the longitudinal moment of inertia of the rocket—that is, adding weight at points far fore and aft of the center of gravity, usually making the rocket longer as well as heavier. The damping ratio and natural frequency of oscillation will decrease, and the rocket will be more difficult to deflect from its intended path. If this is carried to extremes,

however, the rocket will become so heavy that it won't go very high and will experience catastrophic resonance at very low roll rates, resonance so severe that it may behave as if it weren't stable at all. The dramatic increase of resonant amplitude ratio with decreasing damping ratio is shown in Figure

2. There is evidence that some model rockets have actually been caused to crash by excessive resonance at low roll rates early in the flight. Rocket A of Figure 3 is an example of how a model designed with too great a longitudinal moment of inertia might look.

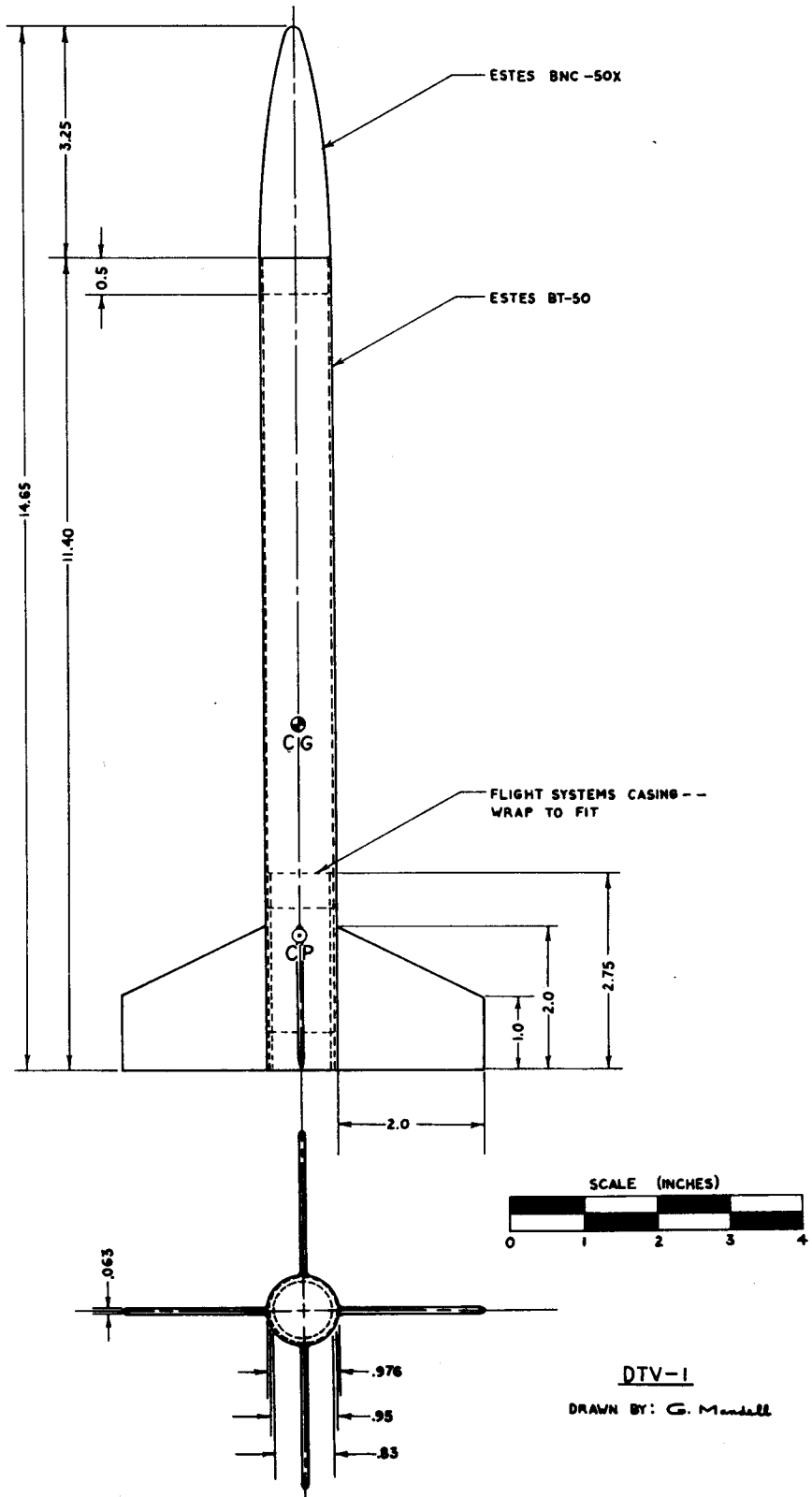

Figure 1. Dynamic Test Vehicle DTV-1, a representative model rocket

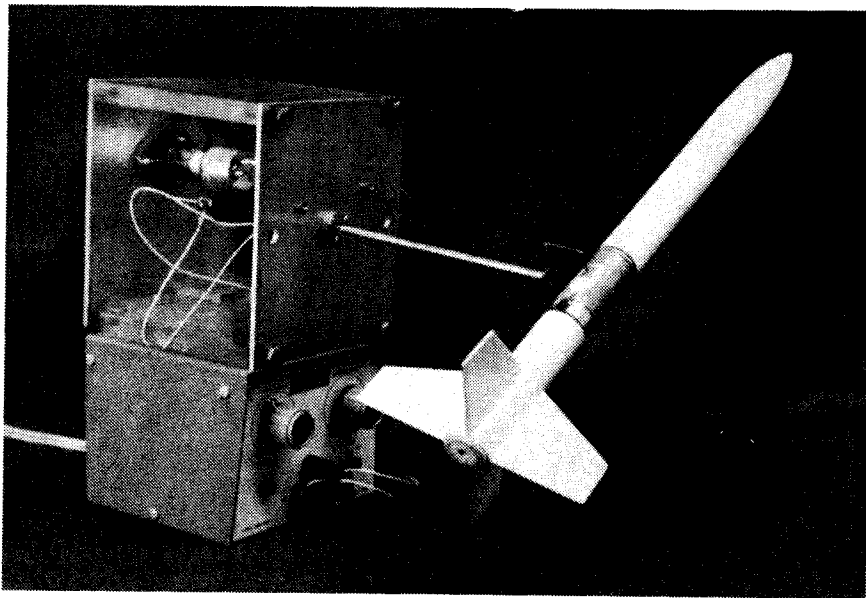

Plate 1. DTV-1 mounted on the dynamic balance system used to investigate its behavior under roll-induced resonance

Decreasing the longitudinal moment of inertia will increase both the damping ratio and the natural frequency. The actual frequency of oscillation will increase only up to a point, then begin to decrease towards zero as the damping ratio approaches 1.0. The resonance problem will disappear, but the rocket will be more easily deflected from alignment with the intended flight path. The slightest disturbance will be enough to set it to wobbling, and although the oscillations will die away after only a few cycles, the rocket will be disturbed so often that it will spend most of its flight upwards at an appreciable angle of attack. Its drag will thus be increased and its altitude lowered—particularly since a low longitudinal moment of inertia usually means a low weight and the rocket may be ballistically off-optimum anyway.\* Continued reduction of the longitudinal moment of inertia causes overdamping, and the rocket behaves as if it had insufficient static stability. An example of this extreme is rocket B of Figure 3. Between 1962 and roughly 1967 there was a "craze" for this kind of design in the United States. People thought that the lighter you built it, the higher it flew, and so constructed their rockets to be very light and stubby, with huge fins. The result was often overdamping, causing severe launcher tipoff, erratic flight paths, and many a pile of wreckage. Thanks to Malewicki, Caporaso, and Barrowman—and to much sad experience and observation—this fetish is today largely a thing of the past.

Now consider increasing the corrective

\*Malewicki and Caporaso have shown that there is a "best" weight for any rocket, which gives the greatest altitude. If the rocket is either heavier or lighter than this optimum weight, it won't go as high.

moment coefficient. If this is done by increasing the static stability margin—by increasing the area of the fins and/or moving them farther toward the rear of the rocket—the frequency at which the rocket oscillates when disturbed (at a given air-speed) will increase. Since altering the fin geometry in this way also increases the damping moment coefficient, the damping ratio will not necessarily decrease; it may even increase if the process is carried to extremes. Thus, the time required for the disturbed rocket to return to proper alignment with the intended direction of flight becomes shorter—and, because the longitudinal moment of inertia has not been changed, the rocket is no easier to disturb than it was before. Everything, at first glance, looks rosy...

Ah, but not so fast; sad but true, there are also disturbances whose magnitude is directly proportional to the static stability margin and normal force coefficient of the model, namely the step disturbances due to horizontal winds. Thus if the value of the static stability margin is made too great the

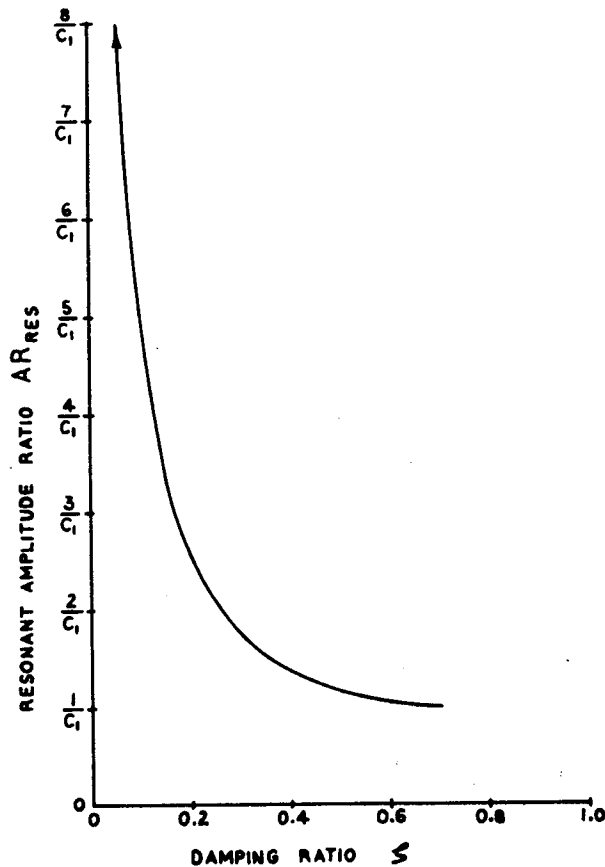
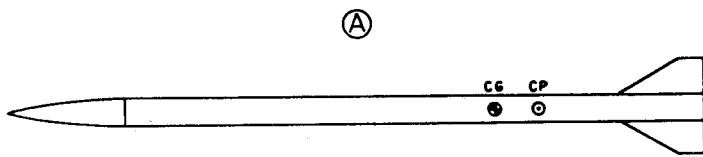
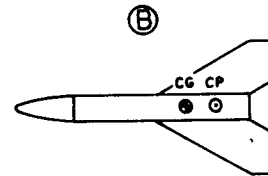

Figure 2. Resonant amplitude ratio as a function of damping ratio



$I_L$  TOO LARGE:  
 $\zeta$  TOO SMALL  
 RESONANCE SEVERE  
 TOO HEAVY



$I_L$  TOO SMALL:  
 EASILY DISTURBED  
 $\zeta$  TOO LARGE  
 TOO LIGHT

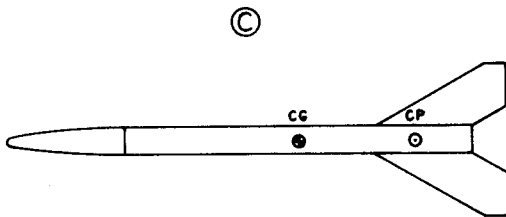

$C_1$  TOO LARGE:  
 WEATHERCOCKING SEVERE

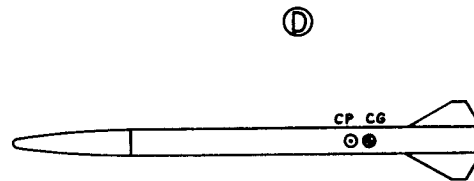

$C_1$  NEGATIVE:  
 STATICALLY UNSTABLE

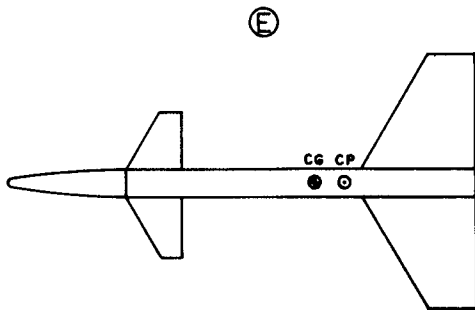

$C_2$  TOO LARGE:  
 $\zeta$  TOO LARGE  
 DRAG EXCESSIVE

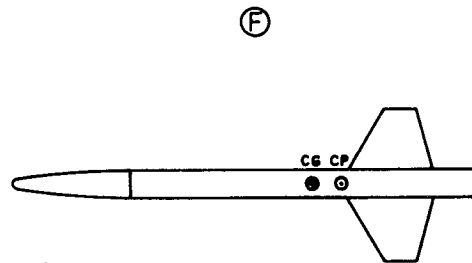

$C_2$  TOO SMALL:  
 $\zeta$  TOO SMALL  
 RESONANCE SEVERE

GM

Figure 3. Improperly designed model rockets resulting from varying the dynamic parameters to values far from those of representative models which have favorable dynamic characteristics

rocket will be subject to "weathercocking," or turning into the wind at launch or even during the entire powered and coasting ascent. This impairs altitude performance, makes recovery difficult, and can be dangerous. Model rockets are not meant for horizontal flight . . . and horizontal flight is what you are likely to get if you try to fly a rocket designed like illustration C in Figure 3 on a windy day.

There is, of course, a better way to get a large corrective moment coefficient. The value of  $C_1$  increases as the rocket's airspeed goes up; in fact, it increases as the *square* of the velocity. Damping moment coefficient, on the other hand, increases linearly with velocity, meaning that the damping *ratio* is velocity-independent. Now, this doesn't mean that you should try for the highest possible velocities throughout the flight. While high burnout velocity generally means higher altitude, excessive velocities cause excessive aerodynamic drag, and (as Malewicki and Caporaso have shown) can actually cause the altitude achieved to be reduced. What it does mean is that you should observe a reasonable minimum in the velocity at which your rocket leaves its launcher. Model rocket engines with end-burning grains are designed with a small port at the after end of the grain, just inside the nozzle. The purpose of this, besides providing a place to pack the igniter, is to provide a high initial thrust to achieve a substantial velocity—and thus, a substantial corrective moment—before the launcher is left behind. You can help the manufacturer to help you by providing a long enough launch rod (or tower) and enough initial acceleration (by using a low enough initial weight) to insure that your rocket leaves the launcher at a sufficient velocity to be stable. 30 feet per second should be considered a minimum safe launch speed; try for 40 feet per second if you can get it. If you are using a core-burning engine, velocities on this order should never be a problem.

*Reducing* the corrective moment coefficient by reducing the static stability margin will cause the natural frequency to decrease. As the center of pressure moves forward and approaches the center of gravity, the damping ratio will increase, lowering the actual frequency of oscillation until overdamping occurs. Moving the center of pressure still further forward will result in neutral, and finally negative, static stability. If this is done the rocket will certainly never fly predictably, for the value of the corrective moment coefficient will be *less than zero*. Only the novice is often caught making a mistake like this, and when he does, the result is spectacular. "Going ape" is the colorful and appropriate phrase applied by the model rocketeer to the behavior of a statically-unstable rocket such as the one shown in illustration D of Figure 3.

The damping moment coefficient at a given airspeed is increased by the addition of fin area or the movement of fins to a

position farther from the center of gravity, in the same way that the static stability margin is increased. Adding large amounts of fin area both forward and aft of the center of gravity, however, and the use of excessive fin area in general, will tend to increase the damping moment coefficient without a commensurate increase in corrective moment coefficient. Dynamically, up to a point (the point at which the damping ratio becomes .7071) this is good. Ballistically, however, such large surfaces are almost always associated with a decrease in altitude because of excessive drag. Working at such high damping ratios is not a good idea in general, anyway, because a slight change of design or modification to a rocket in service or under construction could well send it "over the line" into an overdamped configuration. Rocket E of Figure 3 is an example of what the designer may wind up with if he is too liberal with his sheet balsa.

The damping moment coefficient, insofar as it is dependent on geometry, may be *reduced* by making certain that all fin area is aft of the center of gravity but not greatly distant from it. Since placing the fins relatively near the center of gravity tends to reduce the corrective moment coefficient also, this procedure may not always reduce the damping *ratio* and may even increase it. Reducing the damping ratio to very small values is not a good idea in any case, since under these conditions the oscillations of a deflected rocket persist for a long time and resonance becomes destructively severe. Making the damping moment coefficient too small thus has the same effect as making the longitudinal moment of inertia too large. The rocket of illustration F in Figure 3 has had its damping ratio made too small by placing the fins insufficiently far from the center of gravity. While the designer has apparently been able to keep the static stability margin adequate, his rocket will not be a good performer. Much of its trajectory will be spent oscillating in response to various disturbances even if it doesn't happen to develop a resonant roll rate—in which case its energies will be dissipated in gyrating all over the sky.

The limitations of reasonable design and the standardization of component proportions arising from mass-produced model rocket supplies don't really leave too much leeway for regulating the radial moment of inertia independently of the longitudinal moment of inertia. Assuming that  $I_R$  could be substantially reduced, the effect of such a reduction would be negligible since it is so small to begin with. The radial moment of inertia could conceivably be greatly increased by placing weighted pods, or "bobs" at the tips of the fins, but there would be no point in doing so. No advantage would be gained if the rocket were properly designed to begin with; in fact, there would be some unfavorable consequences attendant upon such a modification. The rate of decay of the rocket's oscillations would be sup-

pressed by gyroscopic moments if it were rolling, and its roll-induced resonance would be significantly more severe than its non-rolling resonant behavior.

## DESIGN PROCEDURES AND CRITERIA

While all this is very interesting and intellectually satisfying, it wouldn't be of much use if it didn't give us any information about how to design a model rocket. Our knowledge about "average" or representative models, however, and our exploration of the effects associated with the altering of the dynamic parameters, do contain the seeds of a rational procedure which permits the model rocketeer to design with a high degree of confidence a model that will behave in a dynamically favorable manner. We outline this method below.

### (1) Center of Gravity and Moments of Inertia:

Estimate the location of your proposed model's center of gravity and estimate its moments of inertia according to the methods of Part III (*Model Rocketry*, January 1969). These quantities will depend on the size, and weight of the parts from which the rocket is to be built, the engine(s) which are to power it, and the payload (if any) which it is to carry. A drawing of the rocket's body and nose is to be made during this step and the center of gravity indicated.

### (2) Static Stability Margin:

Add a fin design to your drawing and compute the location of the center of pressure of the complete rocket by the method of Barrowman. Barrowman's method is described in Centuri Technical Information Report TIR-33, which may be obtained for \$1.00 per copy from the Centuri Engineering Company, Box 1988, Phoenix, Arizona 85001. The center of pressure should lie from one to two calibers (body diameters) behind the center of gravity. If it is outside this range, try a new design. Once you have obtained a satisfactory fin design indicate the center of pressure of the complete rocket and the individual centers of pressure of all its components on the drawing, and note the normal force coefficient of the complete rocket and of each component for later use.

### (3) Damping Ratio:

Using the normal force coefficients and component centers of pressure obtained from step (2), compute the corrective moment coefficient and damping moment coefficient as functions of airspeed according to the equations of Part III. From these, and from the moments of inertia estimated in step (1), compute the damping ratio and the coupled damping ratio. Check to make sure that the coupled damping ratio is not less than 0.05 and that the normal damping ratio is not greater than 0.30. A too-low damping ratio can be cured by lightening the rocket and increasing its fin area; an



excessively high one by adding weight to the nose and decreasing the fin area. While damping ratios up to 1.0 would be theoretically permissible, we have established a tentative upper limit of 0.30 since it is our opinion that more heavily damped rockets are likely to be too light for good altitude performance. The resonant deflection of the rocket's axis from its intended flight path at a damping ratio of 0.3 is only 1.746 times the deflection a static disturbance would produce, as a glance at Figure 2 will reveal. It should thus not really be necessary to use damping ratios higher than this value. In accepting a lower limit of 0.05, on the other hand, we are really pushing the builder's art. In this case the resonant deflection will be *ten times* the static deflection due to a given disturbance. Assuming that a carefully-built model will incorporate unintentional asymmetries causing static deflections of no more than one-half of one degree, a damping ratio of 0.05 will permit such a model experiencing roll-induced resonance to precess about its flight direction with a cone half-angle of five degrees. Clearly, this is about the most we can accept for normal flying.

When these three steps are completed and the dynamic parameters of the proposed design have been found to be satisfactory, construction can be started. It would be desirable to measure the dynamic parameters, or at least the moments of inertia before the first flight to check the accuracy of the estimates and calculations. Barring any major errors in these, the design determined by the above method will be sound.

### SPIN-STABILIZED ROCKETS

Suppose, now, that some hypothetical designer is stuck with a rocket that is insufficiently stable, neutrally stable, or has even a slightly negative static stability margin. What can he do about it? Well, if he really doesn't want to bother properly redesigning his model, he can turn to a last-ditch "fix" commonly (although mistakenly) referred to as "spin stabilization." This technique consists in fitting specially canted or airfoiled fins called spin fins to the rocket body, or in fitting spin tabs or spinnerons to the existing fins. Designs of this type are illustrated in Figure 4. The ship will then begin to roll very rapidly about its longitudinal axis as soon as it clears the launcher, producing large gyroscopic precessional moments in response to any disturbance encountered. As we pointed out in Part II (Model Rocketry, November 1968), the resulting effect is not really stabilization, but suppression of the growth of a deflection that, in a non-rolling statically unstable rocket, would soon result in an "ape" flight. It *looks* enough and *works* enough like stability, however, to keep the flight path reasonably straight and true up to its apex.

For spin stabilization to work well, the

product of the roll rate and the radial moment of inertia must be as large as possible. This means a rapid spin, a high radial moment of inertia, or both. Successful spin-stabilized rockets and projectiles thus tend to be short, squat, and heavy (as in Figure 4.) Last year at the MIT Convention, Bernard Biales, an outstanding model aviator and boost/glide expert, posed me a question on this very point. Well-designed sounding rockets, he noted, are long in relation to their diameters, while artillery shells are short. Why the difference? The reason, of course, is that the sounding rocket is aerodynamically stable while the artillery shell is not. It is an advantage to the shell to have a large diameter in relation to its length because this means a large radial moment of inertia, facilitating spin-stabilization. There is no purpose in giving a sounding rocket a large radial moment of inertia as it does not rely on spinning for its stabilization; furthermore, there is a potential *disadvantage* in such an arrangement. If

the sounding rocket should accidentally develop a roll at the resonant frequency, a large radial moment of inertia would markedly reduce the damping ratio and make the resonance that much worse.

For all our discussion of it, however, spin stabilization is really not the "way to go" in model rocket design. The presence of spin fins or tabs on the rocket may increase its drag by a factor of two or more and badly degrade the altitude performance. In addition, the rapid spin rate invariably tangles the shrouds and shock cord of the rocket's recovery system when ejection occurs. With all the information today available on designing stable model rockets, there is really no excuse for building a model with an inadequate static stability margin. The spin-stabilized rocket is today largely a curiosity, its only conceivable purpose being to demonstrate an unusual property of (what else?) the dynamics of model rockets.

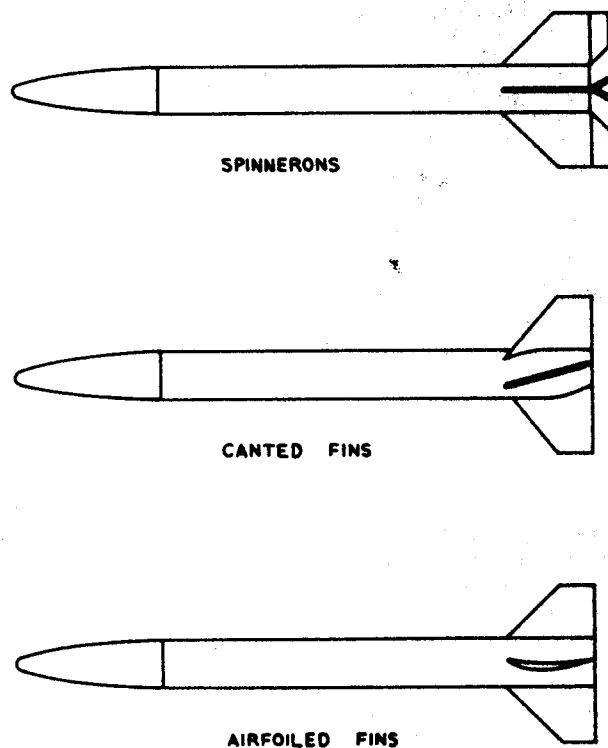

Figure 4. Spin-stabilized model rockets

(From the Editor, cont.)

conventions. The time to start is now. To set up a successful convention requires months of part-time work by a small, dedicated group working on the project. Meeting rooms must be found, housing must be arranged for, guest speakers and discussion leaders must be contacted. . . however, the work is rewarding. The contribution that can be made to the advancement of the hobby by the establishment of regional conventions in every area of the country is significant. This would allow every serious model rocketeer to participate in his regional convention, to come in contact with large numbers of other rocketeers, and to improve the state-of-the-art in model rocketry.

Those model rocketeers who live in areas presently having regional conventions should support their convention by active participation. Only with their support can the presently existing conventions be successful and continue to expand.

(Club Notes, cont.)

feature a model rocket display area. Saturday competition will be in Design Efficiency, Egg-Loft, Class I Parachute Duration, and Sparrow B/G. On Sunday the Space Systems, Scale, and Open Spot Landing events will be flown. There will be a \$1 entry fee plus 25 cents for each event entered. Interested rocketeers in the Washington, Maryland, Virginia region should contact Dick Sipes, (Apt. 101), 5427 85th Avenue, Lanham, Maryland 20801.

The Greater Boston Model Rocket Society has recently become a section of the National Association of Rocketry and is looking for new members. Anyone interested in joining this club should contact Michael Listorti, 71 Waverly Street, Everett, Massachusetts 02149.

Send your club or section newsletters, contest announcements and results, and other news for this column to:

Club News Editor  
Model Rocketry Magazine  
P. O. Box 214  
Boston, Mass., 02123

Say you saw it in

**Model  
Rocketry**

## The Underground Songs of The NAR

*The Underground Songs of the NAR were snatched from an underground song sheet and from hidden tape recorders at NARAM-10. The persons, places and events described are purely fictional (unless you know otherwise). From time to time Model Rocketry will publish selections from the underground song sheet.*

### UN-NAMED VERSE FROM NARAM-9 (Tune: "Jesus Loves Us")

Harry loves us, this we know  
'Cause the Pink Book tells us so.  
File a protest on your flight,  
Pay two bucks if you ain't right.

Yes, Harry loves us; Yes, Harry loves us;  
Yes, Harry loves us; the Pink Book tells us so!

Pinky sits there in a huff;  
Young Jim Barrowman calls his bluff;  
Harry stands there with a frown;  
Old Bob Atwood stares him down.

Yes, Pinky loves us; yes, Pinky loves us;  
Yes, Pinky loves us; the By-Laws tell us so!

Lindsay sits there beard in hand;  
Ole Ed Pearson had it planned;  
With his survey he did smote  
All dissent to Leader vote.

Yes, seniors love us; yes, seniors love us;  
Yes, seniors love us; the Survey tells us so!

Barb & Harry lost their realm  
When Doc Beetch took up the helm;  
Everything looks peachy keen  
'Cause Doc Beetch he ain't so mean.

Yes, Ellsworth loves us; yes, Ellsworth loves us;  
Yes, Ellsworth loves us; because we know it's so.

Casey loves us, this we know;  
He got Humphrey to our show;  
Rosie stands there beaming bright;  
Bendix sits there with delight!

Yes, Casey loves us; yes, Casey loves us;  
Yes, Casey loves us; Because he showed us so.

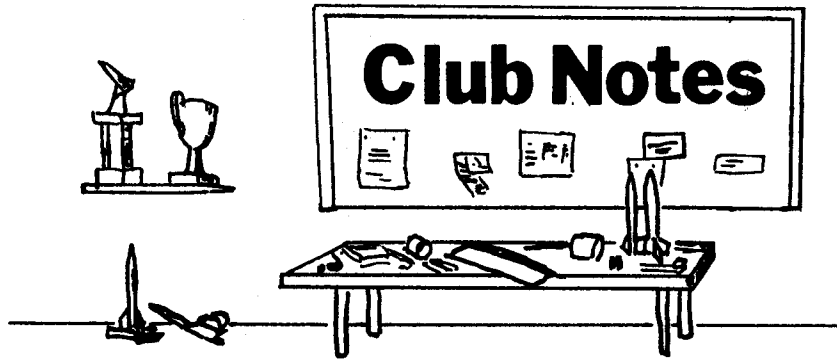

From the Hotline, we have the following: "The Beardstown Rocket Research Association recently received a charter from the National Association of Rocketry for the year 1969. Membership in the NAR means that we will have many additional benefits that we did not enjoy in the past. A few of the benefits are insurance for the club in case of accidents (which we hope never happen), a chance to compete in national competition, and a monthly publication on rocketry for those who belong to the NAR. Membership in the NAR should also give our club more recognition and prestige in our community. Have you joined the NAR?"

The Beardstown section also reports on the progress of their two current projects. A large rocket to be powered by Mini-Max engines is under development with the help of the Arc-Polaris Rocket Club in Portales, New Mexico. Construction of the mobile unit (first reported in Model Rocketry, January 1969) is presently at a stand still because of bad weather and lack of funds to finish it. They hope to have both projects

completed in time for their "big launch" in the spring. Outstanding winners at this competition will have their names engraved on a plaque displayed in the trophy case at the local high school.

A model rocketry club serving eastern Pennsylvania is currently being formed. Rocketeers interested in contests, scale, research, and frequent launches should contact: Youth Director, Bethlehem YMCA, Bethlehem, Pa. 18017 for further information.

The third annual East Coast Regional Meet will be held on the weekend of April 19-20 at Camp A. P. Hill, Virginia. Competition will include the Quadrathon, Egg-Loft, Scale, Swift B/G, Sparrow B/G, and Drag Race. NAR members may obtain further information from Jim Barrowman, 6809 97th Place, Lanham, Maryland 20801.

President Mel Severe of the Metro Denver Rocket Association reports that this club has also joined the NAR for 1969. In

the first edition of the MDRA "Misfire", the results of their November 23rd competition, held at the Estes Industries launching range, were reported. Though two events were planned, time only permitted a parachute duration competition. Casey Hall placed first with a time of 353.0 seconds with an 18 inch parachute on his C6-5 powered rocket. Second place went to Steve Tatman whose 24 inch chute came down after 251.8 seconds. Steve Bryant, Pete Quinn, and Jim Meine placed third, fourth and fifth with 213.8, 202.5, and 193.5 seconds respectively. Prizes for the competition, a Saturn 1 kit to the first place winner and a Saturn V kit for second, were provided by Estes.

The MIT Model Rocket Society has announced the formation of the Massachusetts Regional Conference for Model Rocketry. All clubs in Massachusetts are welcome to join this organization. It has been formed to act as a general organizing body in such activities as promoting legislation and obtaining and organizing launch sites. Interested clubs or individuals should write to the MIT Model Rocket Society, MIT Branch Post Office Box 110, Cambridge, Massachusetts 02139.

The Annapolis Association of Rocketry, an NAR section with 44 members, held a successful pot-luck dinner on January 12. Bob Atwood reports that 103 persons attended the dinner. A static display of model rockets and a NASA film about Apollo 7 were also featured.

WAMARVA I will be held on the weekend of June 14-15 at Fort Meade, Maryland. Over 100 rocketeers are expected to compete in this regional meet which will also  
(Continued on page 31)

## HOBBY SHOPS

Your local hobby shops can supply balsa wood, decals, tools, paint, magazines, and many other model rocket supplies.

Mention Model Rocketry to your local hobby dealer.

Western New York Headquarters for Rockets and Supplies is  
**GRELL'S FAMILY HOBBY SHOP**

5225 Main St.  
Williamsville, New York

Open 7 days a week

Phone 632-3165

**MODEL ROCKET SUPPLIES**

**TOTOWA HOBBY SHOP**

Harold M. Zafeman

388 Union Ave.  
Paterson 2, N. J.  
279-0106

We Sell Estes Rocket Kits  
and Supplies  
Mail Orders Filled  
**PAVONE'S SHOE HOSPITAL**  
20 Margret Street  
Plattsburg, New York, 12901

Tell your Hobby Dealer you saw it in  
**MODEL ROCKETRY**

NOW AVAILABLE: A Visual Tour of the Solar System  
**EXPLORING SPACE WITH A CAMERA**

NASA Special Publication 168. Edited by Edgar M. Cortright,  
 Director of the Langley Research Center

This is an album of the finest pictures of the Earth, the Moon, and Mars, taken from America's spacecraft. A National Aeronautics and Space Administration official chose them from the tens of thousands of photos obtained in the first 10 years of space exploration. Many are in full color. All of them are interpreted and explained in captions by outstanding authorities.

These photos show you the Earth's beauty when it is seen from afar. They depict its lands, seas, and clouds — and puzzling features of the Moon indicative of the solar system's history. "I hope this book can find its way into many American homes," NASA Administrator James E. Webb wrote, "for it is a part of a record of achievement of which our country can be proud."

1968, 214 p. 9 x 11½

Clothbound, \$4.25

THIS MAGNIFICENT OBLIQUE shows the Marius Hills, shortly after local lunar sunrise. Those domes are as much as 10 miles in diameter; irregular lines are believed to be ancient lava flows.

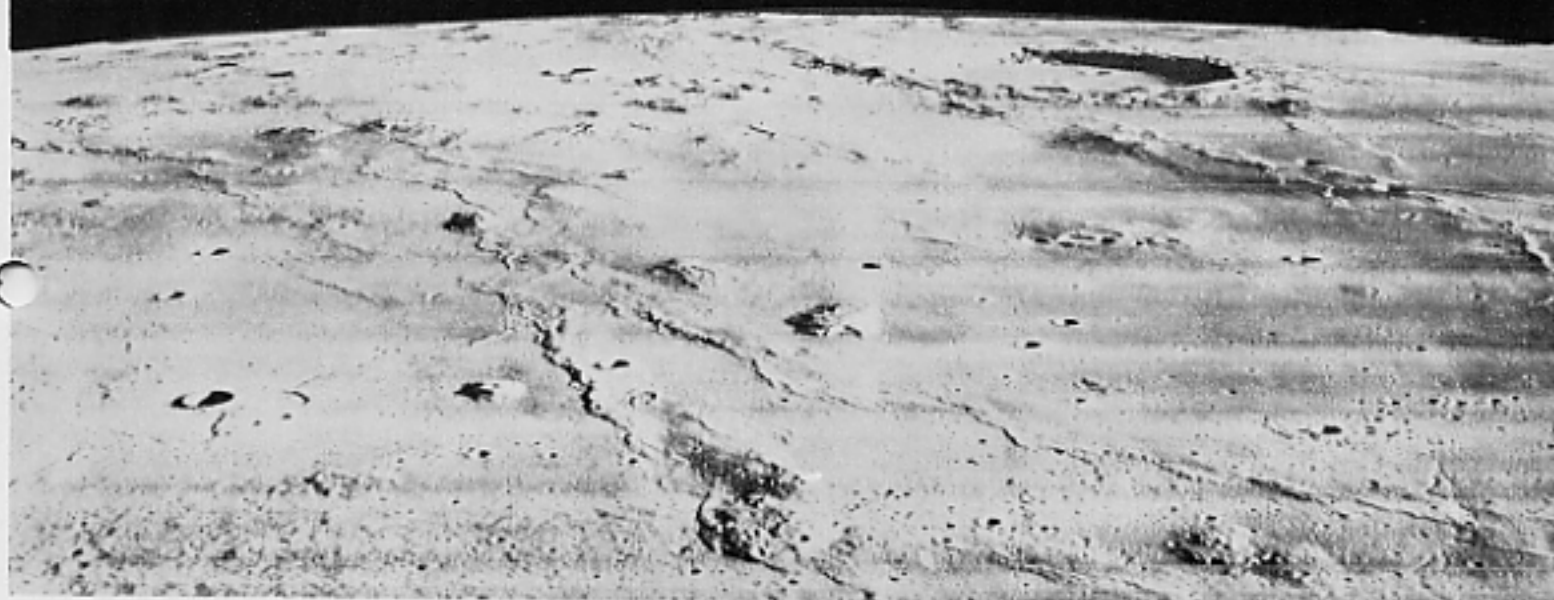

**MAIL ORDER FORM To:**

Superintendent of Documents, Government Printing Office, Washington, D.C. 20402

Enclosed find \$..... (check, money order, or Supt. of Documents coupons). Please send me .....  
 copies of EXPLORING SPACE WITH A CAMERA, at \$4.25 a copy. (Catalog No. NAS 1.21:168)

Please charge this order  
 to my Deposit Account  
 No. ....

Name .....  
 Street address .....  
 City and State ..... ZIP Code .....

**FOR USE OF SUPT. DOCS.**

Enclosed.....  
 To be mailed.....  
 later.....  
 Subscription.....  
 Refund.....  
 Coupon refund.....  
 Postage.....

☆ GPO : 1968-O-325-136

FOR PROMPT SHIPMENT, PLEASE PRINT OR TYPE ADDRESS ON LABEL BELOW INCLUDING YOUR ZIP CODE

U.S. GOVERNMENT PRINTING OFFICE  
 DIVISION OF PUBLIC DOCUMENTS  
 WASHINGTON, D.C. 20402

**OFFICIAL BUSINESS**  
 RETURN AFTER 5 DAYS

POSTAGE AND FEES PAID  
 U.S. GOVERNMENT PRINTING OFFICE

Name .....  
 Street address .....  
 City and State ..... ZIP Code .....

MODEL ROCKETRY

**ESTES**

SCIENTIFIC SPACE AGE HOBBY

# ROCKETS

FLIGHTS UP TO 2500 FT.

*Count down with Estes Rockets, and lift off with the very best in model rocketry. Order the Estes Starter kit today. Let the Estes program of model rocketry guide you in the challenge of design, exploration and experimentation in a whole new range of space science interests.*

Ideal father-son activity  
and hours of fun for all  
the family

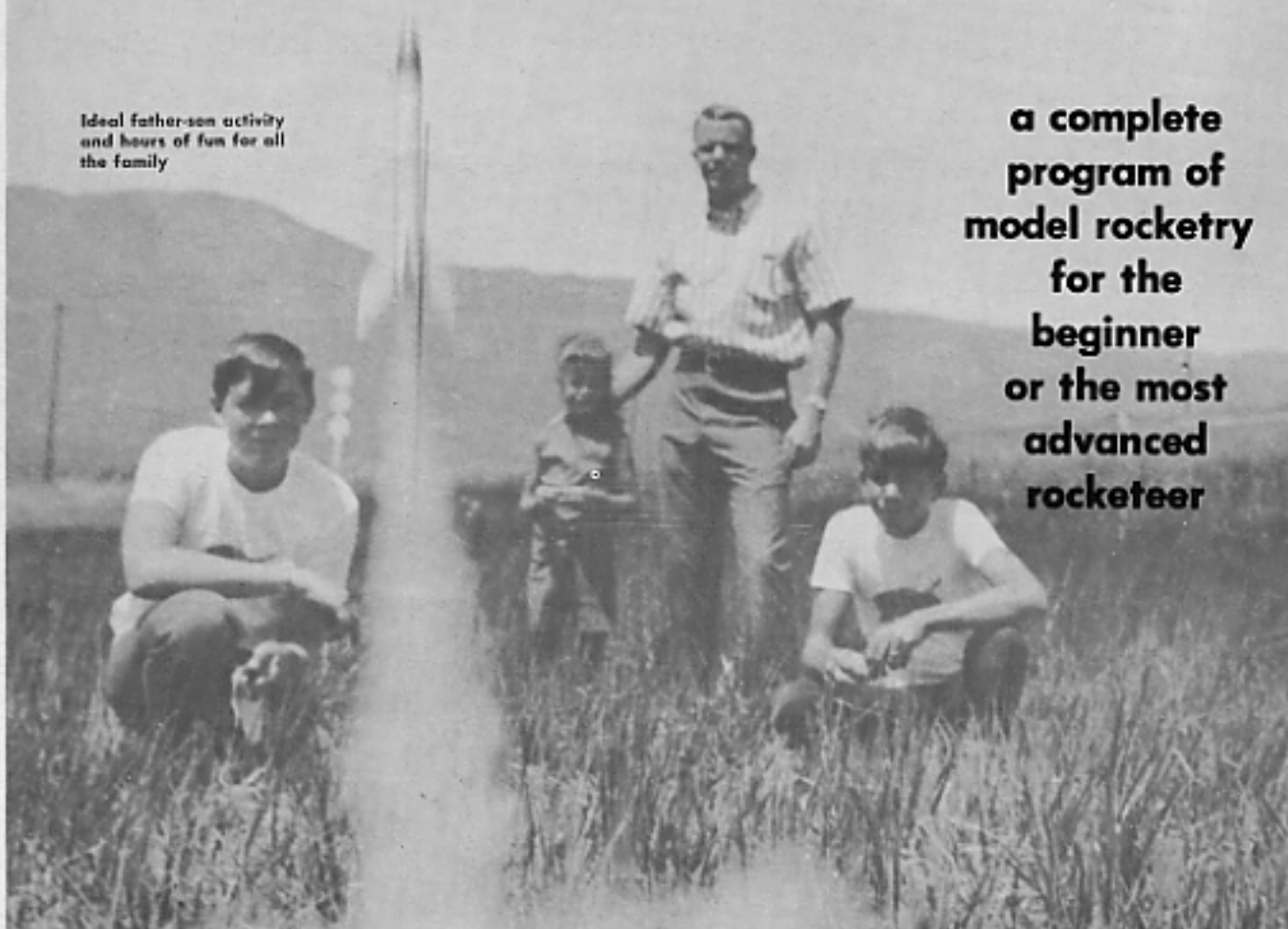

**a complete  
program of  
model rocketry  
for the  
beginner  
or the most  
advanced  
rocketeer**

Look for Estes  
rockets at your  
hobby store

IF NOT AVAILABLE  
SEND THIS COUPON

Estes Industries, Dept. 31 — Box 227, Penrose, Colo. 81240

Please send me the following:

- Starter Special #DSK-20. Includes high flying Astron Alpha kit, 2 powerful engines, complete instructions and design manual..... \$2.00
- #DSK-65 — Same as above plus electric launching system, with batteries..... \$6.50
- Hugo, illustrated color catalog..... (free with kit order)..... 25¢

NAME..... ADDRESS.....

CITY..... STATE..... ZIP.....