

# MODEL ROCKETRY

February 1969

35 ¢

The Journal of Miniature Astronautics

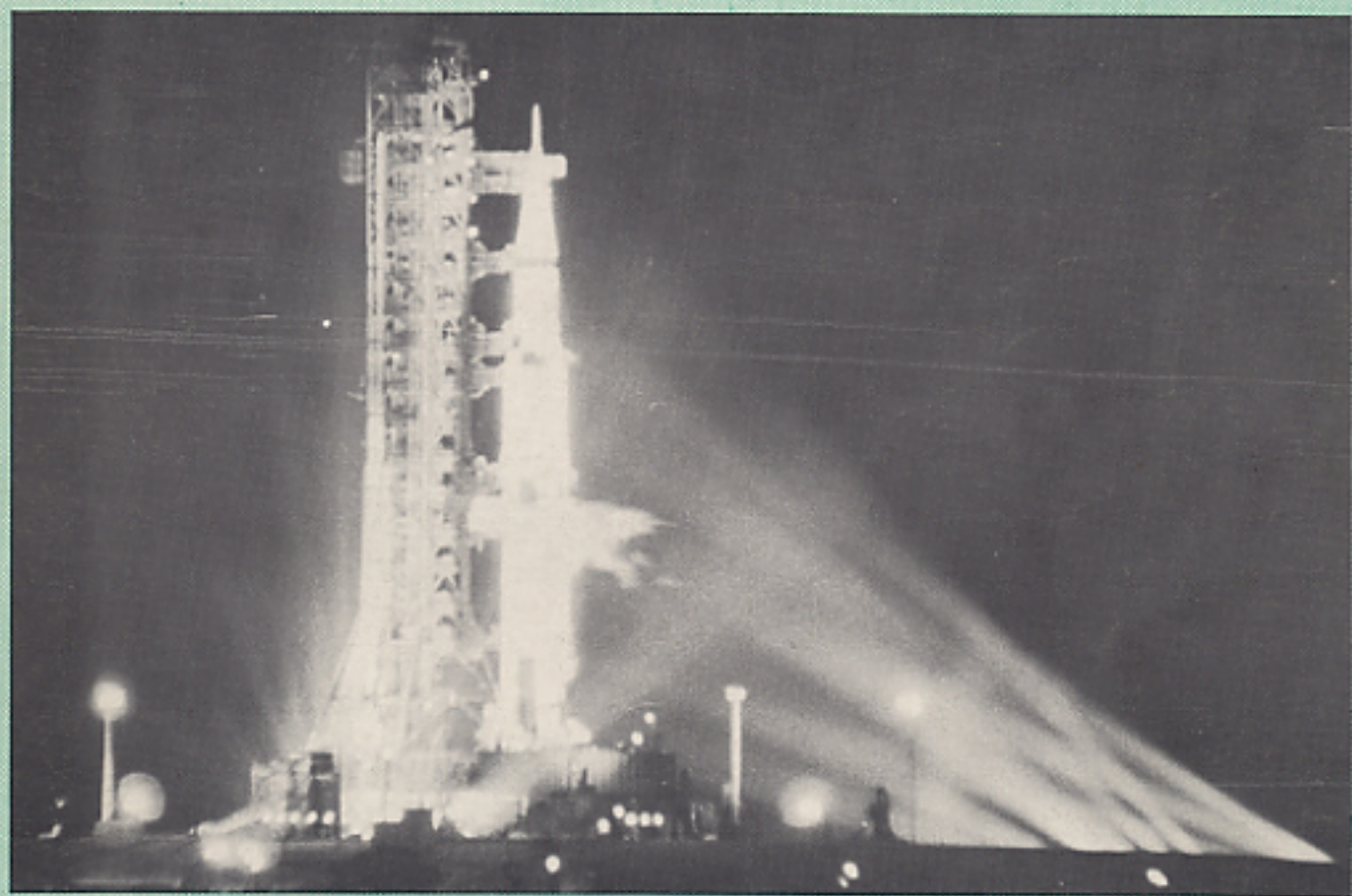

ZETA SPORT ROCKET

COSMIC AVENGER FOR E ENGINES

NON-VERTICAL TRAJECTORY ANALYSIS

NIKE-DEACON SCALE

DYNAMICS IV

REGULAR FEATURES

# Model Rocketry

Volume I, No. 4

February 1969

Editor and Publisher  
Managing Editor  
Business Manager  
Distribution Manager

George J. Flynn  
Gordon K. Mandell  
George J. Caporaso  
Thomas T. Milkie

This month's cover photo shows the Saturn V/Apollo 8 vehicle on the launch pad at the Kennedy Space Center in the early morning of launch day. An article on the flight of Apollo 8 begins on page 7. (Cover photo by George Flynn)

## From the Editor

In recent months we have seen club and section newsletters from a few of the groups actively engaged in model rocketry. These newsletters range from simple, one-page hectographed bulletins to elaborate, multi-page productions requiring many days of effort on the part of the club members. However, if the number of club newsletters crossing our desk is any indication, a majority of the model rocket clubs in this country have no regular club publication.

Perhaps many rocketeers feel that communication at club meetings and launches is sufficient. But, if there is no newsletter, other modelers throughout the country have no way of knowing what projects you have undertaken.

The advancement of any hobby can only come about when all the participants have the benefit of each other's discoveries, the means to learn from each other's successes, and to keep from repeating each other's mistakes. To do this, effective communication of information is necessary. We hope that many of the clubs not presently publishing club newsletters will consider doing so at the earliest opportunity.

World Championships Scheduled	3
Zeta Single Stage Sport Rocket <i>by Thomas Milkie</i>	4
Non-Vertical Trajectory Analysis <i>by George Caporaso</i>	6
The Flight of Apollo 8 <i>by George Flynn</i>	7
The Old Rocketeer <i>by G. Harry Stine</i>	12
Model Rocketry for the Depraved <i>by Joel S. Davis</i>	14
Scale Design: Nike Deacon <i>by George Flynn</i>	16
Model Rocket Carries Movie Camera	19
Cosmic Avenger <i>by George Caporaso</i>	20
Fundamentals of Dynamic Stability <i>by Gordon K. Mandell</i>	23
Features	
Letters	2
Tech Notes	10
Photo Gallery	11
Q & A	15
Reader Design	31
Club Notes	32

Model Rocketry magazine is published monthly by Model Rocketry, Inc., Box 214, Boston, Massachusetts 02123.

Subscription Rates: U.S. and Canada, \$3.50 for 1 year; \$2.00 for 6 months; 35 cents for single copy. Foreign, \$6.00 for 1 year; \$3.50 for 6 months; 60 cents for single copy.

Material submitted for publication should be accompanied by a self-addressed, stamped envelope if return is desired. We can assume no responsibility for material lost or damaged; however care will be exercised in handling.

Advertisers should contact Advertising Manager, Model Rocketry, Box 214, Boston, Massachusetts 02123 for advertising rate cards and information.

© Copyright 1969 by Model Rocketry, Inc.

## SPECIAL OFFER!

Beautiful, full-color photograph of the Apollo 7, Saturn 1B liftoff of October, 1968

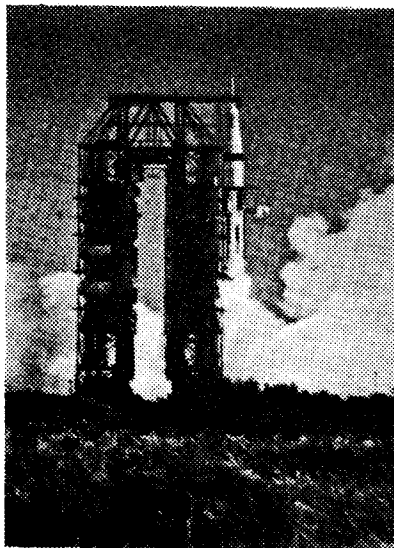

This magnificent photograph of a most historic moment in the history of spaceflight was obtained by Model Rocketry editor George Flynn from an advance position not accessible to most Kennedy Space Center visitors. Showing the moment of liftoff, this 7 by 8 inch full-color print will make an inspiring addition to the album of any space enthusiast.

Full-color copies of the photograph, which is reproduced in black and white above, may be obtained by sending 50¢, or \$1.00 for 3, to:

Saturn Photo  
Model Rocketry  
Box 214  
Boston, Mass. 02123

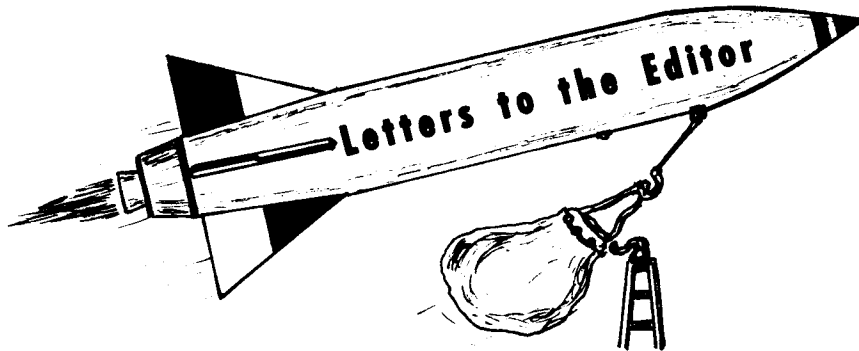

### State Laws

Recently I sent away for a sample copy of your magazine. Upon receiving your magazine, I am overjoyed to see the first full-length magazine devoted entirely to the sport of model rocketry. I enjoyed every section of your magazine. However, I would like to point out one article which I read with interest. This article, entitled *From the Editor* impressed upon me the fact that at last someone is paying attention to the fact that a great number of model rocketeers in this country are banned from the launching of model rockets. You probably know that Massachusetts is a state which has outlawed model astronautics by placing it under the heading of fireworks. I am actively engaged in the struggle of modifying our General Laws so that model rocketry is permitted. At the present time we cannot fire off model rockets; however due to the interest of Mr. Paul Cronin of Andover and his group, he has petitioned our state House of Representatives with a bill that allows the launching of model rockets under supervision. This bill will come under the discussion of the House this coming January, and I believe with the NFPA Code of Model Rocketry as convincing evidence of the fact that model rocketry is a very legitimate aeromodeling activity, that model rocketry is extremely safe, and that model rocketry is an educational activity; that our state legislature will approve this bill, but only with more continued support by interested individuals and civic groups.

Your articles on dynamic stability were excellent, but some of my fellow modelers could not understand the material so I think that with all these articles you should define the terms you use. The rest of the contents of your magazine were also very good. I think in the future that you should add a section in your magazine simplifying advanced topics for the beginner as well as a section for the more advanced rocketeer. You should enlarge your New Product Notes, Questions and Answers, and your

### Technical Notes sections.

James J. Bonner  
Holbrook, Mass.

### Manufacturers

Enclosed find a check for \$3.50 to cover a one-year subscription to your magazine.

Also, if possible, could you send to me the names of the major manufacturers of kits, engines, and supplied.

Richard DeSwarte  
Rockford, Illinois

*New manufacturers are continually entering the model rocket field. The best way to obtain an up-to-date listing of companies interested in selling hobby supplies and rockets to serious model rocketeers is to watch the pages of Model Rocketry for their advertisements.*

### Articles?

I received your publication several weeks ago and I wish to commend you on a very excellent magazine that you have produced. I am looking forward to the development of your various columns as well as advertising.

Would you also send information on what articles you would prefer for publication. Although I am only a Junior I like to keep my mind working on such things since it is fun.

Tancred Lidderdale, Jr.  
Dalton, Ga.

*We will consider for publication any articles relating to the technical aspects of model rocketry, articles on the construction of support and test equipment, design and scale articles, and general articles on constructing, finishing, and flying model rockets. If you have a particular topic you would like to write about, either send us a letter describing the proposed article or submit the finished article to Model Rocketry.*

(continued on pg. 15)

# First World Championships in Yugoslavia in 1970

## NARAM-11 to be Held at U.S. Air Force Academy

### Editor's Note:

G. Harry Stine, who is Chairman of the Liaison Committee of the National Association of Rocketry and President of the C.I.A.M. Rocketry Subcommittee, communicated the above release to Model Rocketry upon his return from Paris, where he had been attending the meetings of the C.I.A.M. Plenary Committee and C.I.A.M. Rocketry Subcommittee. He also prepared a memorandum for the NAR concerning his participation in the meetings, which reads as follows:

"I travelled via Military Airlift Command from McQuire AFB, N.J. to Frankfurt-am-Main, Germany on November 19-20, 1968 and from Frankfurt-am-Main to Paris via train on November 20, 1968 to attend the C.I.A.M. meetings and to chair the C.I.A.M. Rocketry Subcommittee meetings in Paris, France.

"I attended the meeting of the C.I.A.M. Bureau (officers) at F.A.I., 6 Rue Galilee, Paris on November 21, 1968 for the purposes of being available to the C.I.A.M. Bureau regarding any questions about the Rocketry Subcommittee. This was at the written invitation of the President of the C.I.A.M.

"The Rocketry Subcommittee met on November 22, 1968 and minutes of the meeting are attached.

"I attended the C.I.A.M. Plenary Meeting on November 23, 1968 at the F.A.I. headquarters. All provisions of the Subcommittee minutes and all recommendations and suggestions were adopted by the C.I.A.M. In most cases, only those nations having model rocketry voted for the propositions, the remainder abstaining. The only vote cast against a proposal was for the 1970 World Championships when Switzerland cast a negative vote.

"We have been exceedingly fortunate in having the Scale rules adopted officially on the first presentation to C.I.A.M. and in getting approval for the 1970 Yugoslavia World Championships. This is most unusual in the annals of the C.I.A.M. (Maybe the delegates didn't realize what they were voting for!)"

In a move unprecedented in the annals of international aeromodelling sport, a World Championship competition for model rocketry was approved only two years after official international competition rules were adopted and only 6 years after the initial presentation of model rocketry was made to an international body.

On November 23, 1968, the International Aeromodelling Committee (C.I.A.M.) of the Federation Aeronautique Internationale, meeting in Paris, approved the bid of Yugoslavia for hosting the first World Championships in model rocketry at Vrsac, Yugoslavia, in 1970. The exact dates have not yet been established. Authorized for the meet are competition events in the categories of flight duration with a parachute, flight duration with a rocket glider (boost/glider), and scale models. (The scale model rules were also adopted at the same time as the approval for the World Championships.)

The World Championships will be held under the international model rocketry rules of Part 4b of the F.A.I. Sporting Code. Each nation will be permitted to send at least one team made up of three model rocketeers and a team manager; more teams can be entered if desired.

At the same time, the F.A.I.'s International Aeronautical Sporting Calendar for the year 1969 listed the 11th United States National Model Rocket Championships on its roster of First

Category Events. NARAM-11 is scheduled for August 11 through 15, 1969, and is to be held at the United States Air Force Academy near Colorado Springs, Colorado.

The Federation Aeronautique Internationale is made up of over 60 nations and has international jurisdiction over all aerospace sport ranging from certifying flight records in astronautics to establishing rules for international competition in parachuting, aerobatics, ballooning, gliding and soaring, distance and speed records, model aircraft and model rockets. The C.I.A.M. of the F.A.I. is its governing body for aeromodelling.

Model rocketry was first presented to C.I.A.M. in 1962 by G. Harry Stine of the United States. A Rocketry Subcommittee was formed with Stine as Chairman to draw up proposed sporting competition rules. These rules were adopted on a provision basis by C.I.A.M. in 1964. When 1966 rolled around the first international competition (but not a World Championships, which is a different contest category) was flown at Dubnica, Czechoslovakia and the rules were adopted as official in Paris later in the year.

Since our hobby originated in the United States in 1957, the roster of nations engaged in model rocketry has grown to include Sweden, Belgium, Czechoslovakia, Poland, East Germany, Hungary, Bulgaria, Yugoslavia, Canada, Australia, the U.S.S.R., and the United States.

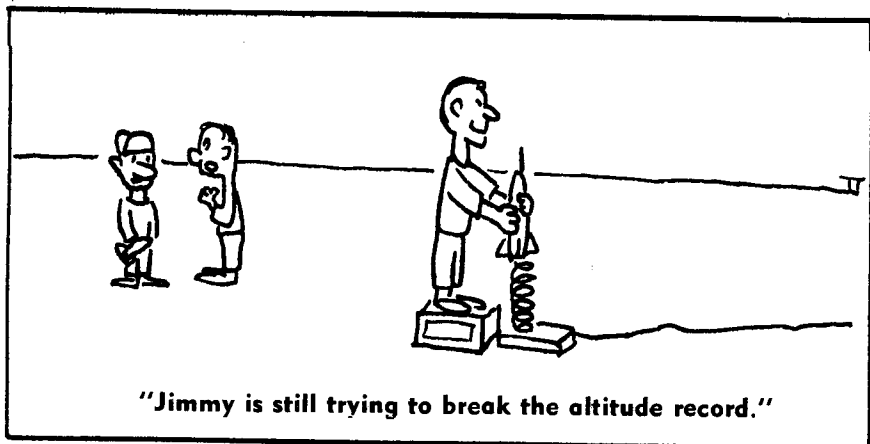

# The ZETA

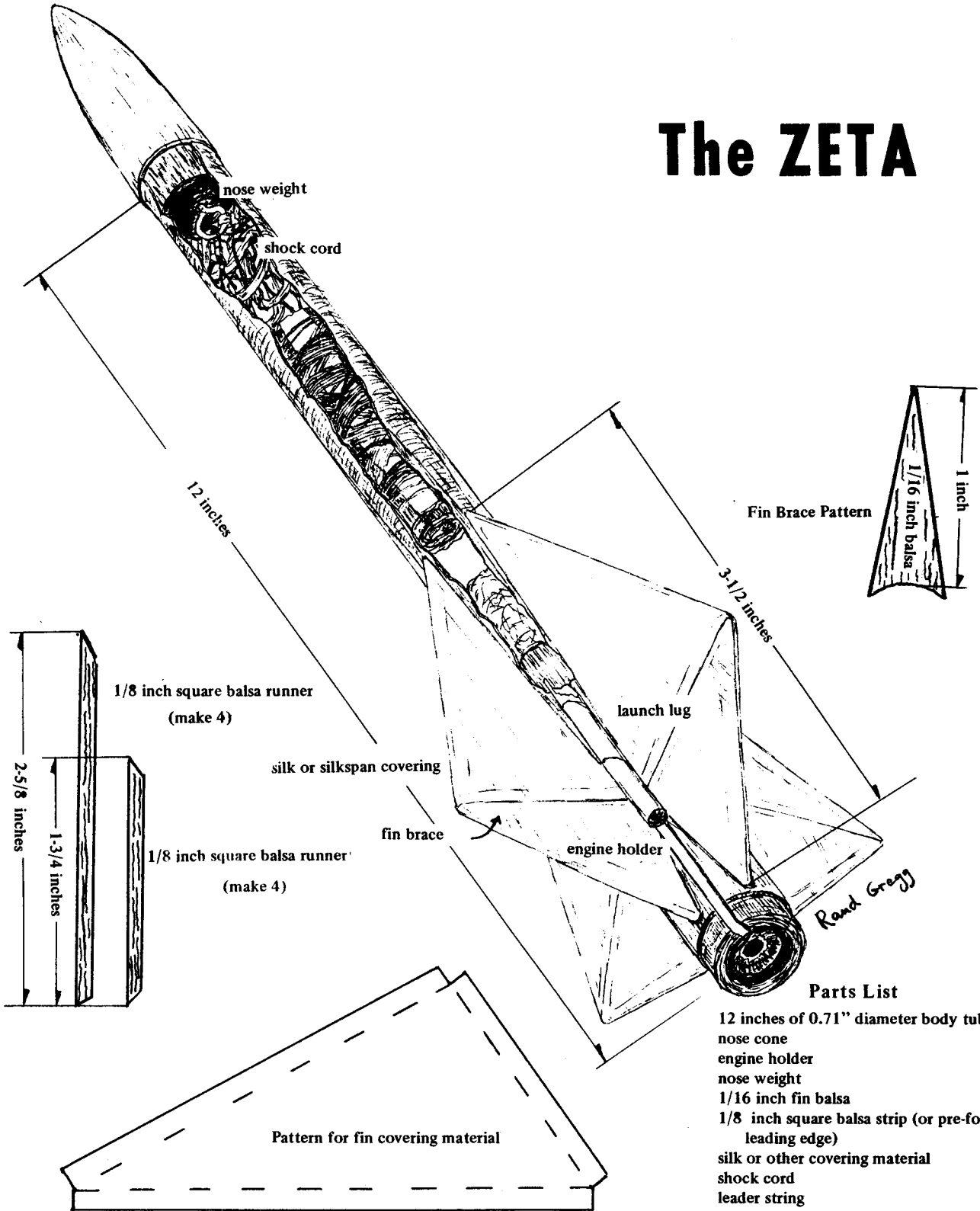

## Parts List

- 12 inches of 0.71" diameter body tube
- nose cone
- engine holder
- nose weight
- 1/16 inch fin balsa
- 1/8 inch square balsa strip (or pre-formed leading edge)
- silk or other covering material
- shock cord
- leader string
- snap swivel
- screw eye
- parachute
- glue, dope, paint, etc.

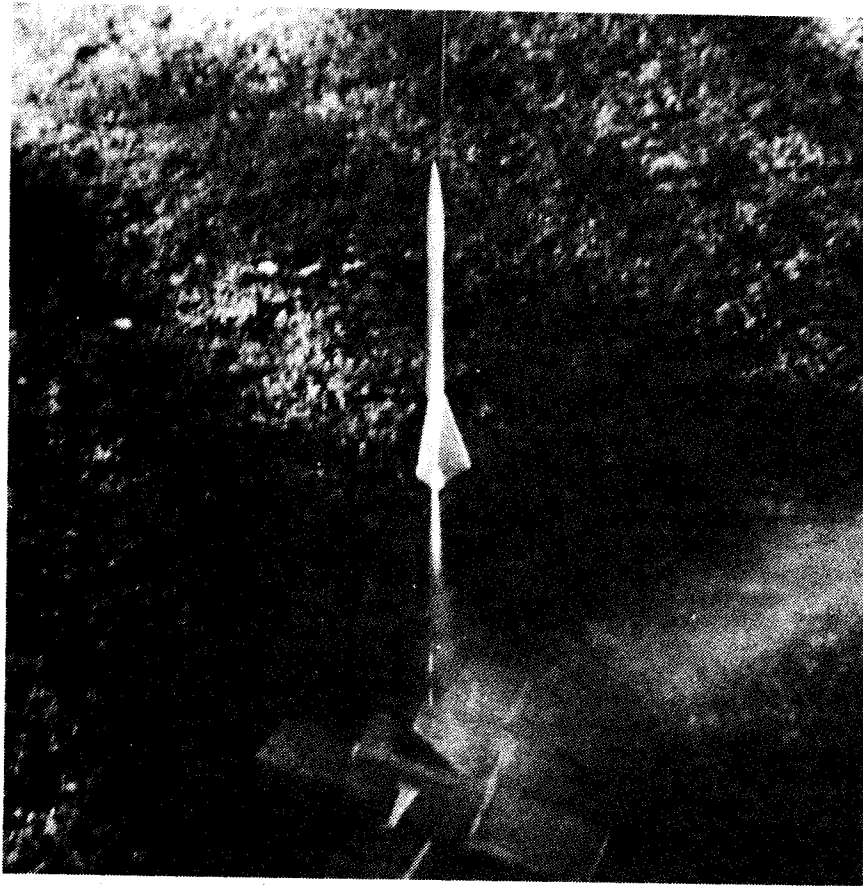

Photo by Tom Milkie

### The ZETA lifts skyward.

The Zeta is a single-stage sport rocket which uses built-up fin construction similar to wing or stabilizer construction on larger model airplanes.

It is best to make the fins first so that they can dry while construction proceeds on the rest of the rocket. First cut the center braces out of 1/16th inch balsa wood using the pattern. The four braces should completely surround the body tube except for a 1/8th inch space between two of the fins. This space is for placement of the launch lug and the engine holder. Using a straight piece of paper wrapped around the body tube, mark a line all the way around the body tube, approximately 1 inch from the bottom. Now glue the fin braces onto the body tube at this line.

Next, cut 4 runners 1-3/4 inches long off a 1/8th inch square balsa strip. Also cut 4 runners 3-1/2 inches long for the front of the fins. Try to obtain a piece of hard balsa strip for the runners. If you do not have any balsa strips, it is an easy matter to slice some off a 1/8th inch balsa sheet using a straightedge and sharp modeling knife.

In order to fit properly, these runners should have their ends sanded to the proper angle. To do this place a sheet of sandpaper on a flat surface, grip 4 runners together in a

row, and run them back and forth sideways, holding them at the proper angle as shown in the drawing.

Next sand a leading edge onto each runner. It may be more convenient to sand the strip before cutting it into runners but this will make it more difficult to hold the runners while sanding the ends. Some hobby shops also stock pre-shaped leading edges which may be used.

Attach the engine holder to the body tube before proceeding. Punch a small slit in the body tube about 2-5/8ths inches up from the bottom, between the fin braces which were left separated by 1/8th inch. Using a piece of silk or other cloth about 1-1/2 inches by 1/2 inch, mount the engine holder at its top. The engine holder should extend a slight distance behind the rear of the rocket.

Now mount the body tube front end horizontally on a shelf or table edge so that the fin runners can be attached. Using a liberal amount of white glue or airplane glue, mount the runners and line them up properly. The runners should be glued to the side of the fin braces.

While the glue is drying, assemble the recovery system. Attach the leads to your parachute and a snap swivel. Install a

screw-eye into a nose weight and screw into a long nose cone. Apply sanding sealer to the nose cone and sand until a smooth finish is achieved, then attach a long shock cord and the parachute to the screw-eye. Attach the other end of the shock cord to a 2-foot string leader. A long shock cord and leader will prevent the nose cone from snapping back after it pops off at ejection, which could damage the body tube and nose cone. Punch a very small hole in the front end of the body tube about 1 inch from the end. Push the leader through this hole and tie a double knot in the end. Cut off the excess string and put a dab of glue over the knot and hole.

After all runners have been attached and the glue is dry the fins may be covered. Silk or nylon are best for covering the fins, but new materials (such as Shrinktite and Coverite) or silkspan (tissue) may be used. Most of these are available where model airplane supplies are sold. 1/32nd inch balsa may also be used, but the finishing of the fins will add tail weight. Cut 8 forms to the oversize pattern shown. Apply glue or dope to the runners, brace and body tube and apply the covering material. After everything has dried a light spray of water from a window cleaner spray bottle or an old tooth brush will shrink the covering tight. Be careful, however, not to shrink the covering too tight or it will warp the fins or pull itself off the frame. Bend the covering over the runners and cut off any excess on all sides. When all 4 fins are covered, apply clear dope to the material to seal it. Make certain during the glueing and doping that the engine holder is free to bend outward. Glue the launch lug on top of the engine holder just forward of the widest part of the fins.

Next assemble the recovery system so that the nose cone can be attached. Sand the entire body tube lightly, then apply coats of clear dope as desired. Next spray or brush on your favorite color dope or paint. When painting a two-color scheme it is best to roughly brush on the lighter color first. After it is completely dry, mask over all areas which are to remain the light color. Run your thumb nail along all edges of the masking tape to insure that no paint will flow over the other color.

If the fins are damaged a piece of cellophane or plastic tape will repair any tears which have occurred on the launch field. For permanent repairs a small piece of silkspan or cloth can be doped over the hole and painted into the color scheme. Also a piece of Monokote (the regular kind which sticks without heat) may be used.

The use of built-up fins can lead to many other new rocket designs. With specially designed fins it may be possible to put the recovery system inside the fins of a rocket. Maybe someone can be inventive enough to put the entire rocket inside the fins!

The subject of purely vertical altitude calculation has received admirable treatment by Malewicki and others, but the subject of obtaining closed form solutions to the differential equation of motion for a rocket launched at any angle with respect to the ground have not been discussed. The author has derived such closed form approximations and presented them to the 1968 MIT National Convention. This article is based on that presentation.

The differential equations of motion for the horizontal and vertical components of motion are derived in the box (fig. 1). The remarkable thing about the equations is that they are separable. That is, the solution of the vertical component does not depend on the horizontal component and vice versa.

Several simplifying assumptions were made in order to make the problem amenable to a solution by closed form equations. First, it was assumed that the rocket is launched at some initial angle with respect to the ground and that this angle does not change appreciably during the burning period of the engine. Since most engines have burning times on the order of 1 second and in that time, the deviation from the straight flight path could amount to no more than 16 feet, the approximation is a good one since by that time the rocket is several hundred feet in the air.

The next assumption was that of a relatively small weight change in the rocket compared to the rocket's weight. Under this assumption, a first order correction for variable mass was used as it was in the case of the vertical equations of motion.

It was also assumed that the rocket did not oscillate much during the flight (i.e., it possessed excellent dynamic stability).

Several graphs are presented for different weight rockets with different engines at a launching angle of 45 degrees. A graph is also presented which shows the effect of the launching angle on the range and altitude for one particular rocket.

One feature will be noticed in all these curves that is different from the classical, no drag picture. In that approximation, the trajectory is symmetric about a vertical line drawn through the apex of the flight. But it is seen that the actual curves are asymmetric about this point because of drag. After burnout, the drag is unopposed by the thrust of the engine and it drastically slows the horizontal velocity of the rocket causing the curve to bunch up after burnout. This effect is most pronounced for light weight, high thrust, high drag rockets and becomes less visible as the drag of the rocket is decreased and the weight is increased.

The same curves are in general similar to those for multistaged rockets although these are not presented here. The equation in fig. 1 can be readily extended to cover such cases.

# Non-Vertical Trajectory Analysis

by George Caporaso

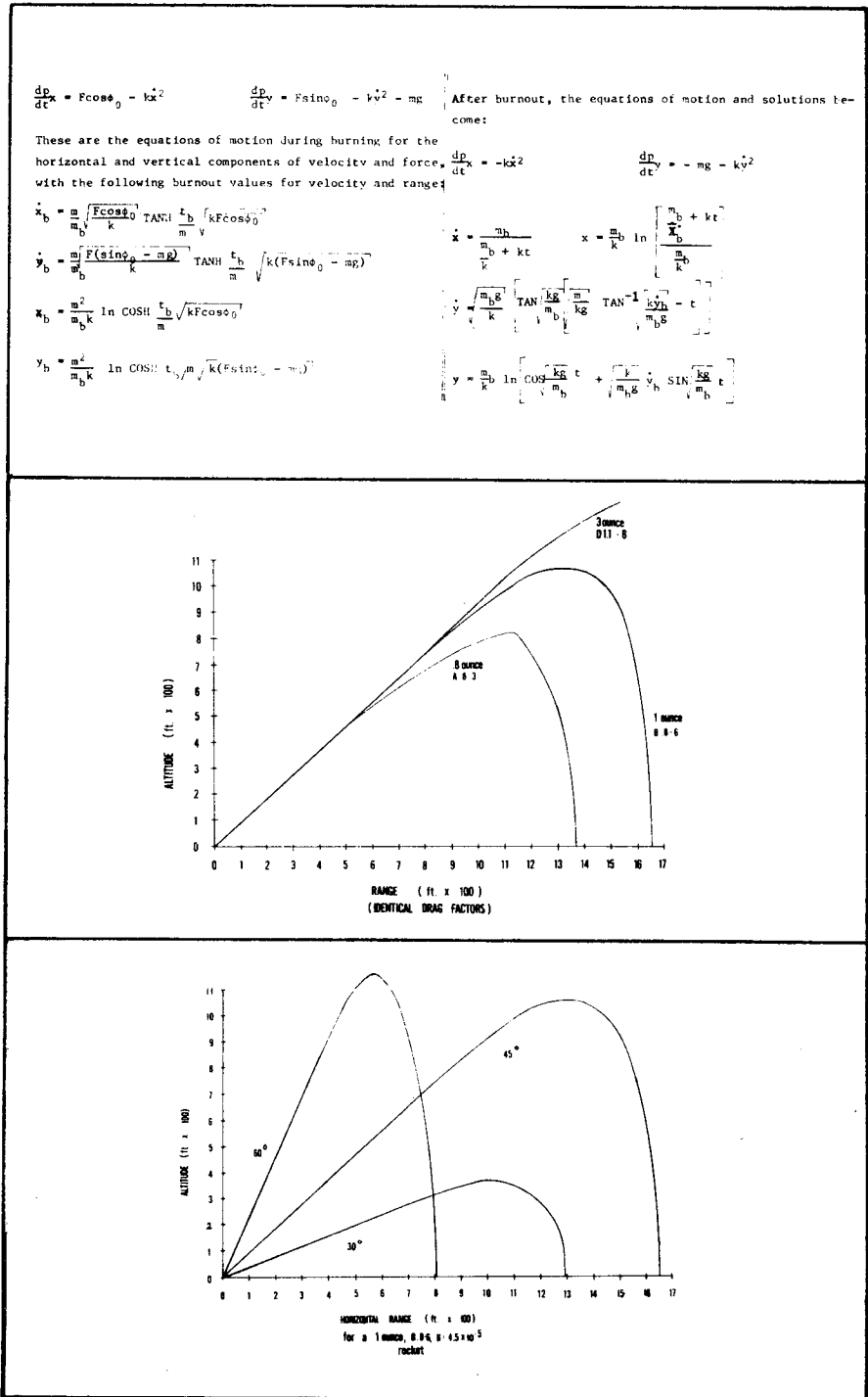

# The Flight of Apollo 8

by George Flynn

The day of December 21, 1968 began early for the crew of Apollo 8. Astronauts Frank Borman, James Lovell, and Bill Anders were awakened at about 2:00 AM. They passed a final pre-flight medical exam, ate breakfast, and donned their spacesuits. At 4:30 AM, well before dawn in the Florida winter, they departed from the crew quarters of the Manned Spacecraft Operations Building. The crew walked briskly through the door, waved at the waiting reporters and NASA employees, and disappeared quickly into the transfer van. The van pulled away on its way to Launch Pad A of Complex 39 – launch site of the world's most powerful rocket, the Saturn V.

The pre-launch countdown was running about 10 minutes ahead of schedule when the crew arrived at the pad, and the astronauts quickly boarded the spacecraft. The backup crew, who had been participating in the pre-launch capsule checkout during the night turned the Apollo 8 capsule over to the prime crew.

Bright searchlights illuminated the rocket all during the night. The spectacular light display was visible over 25 miles from the pad. The sky was clear, with many stars visible, defying the weatherman's prediction of low-level clouds which would have scrubbed the launch.

There were no holds in the count, and at 7:51 AM the Saturn V rocket, for the first time, carried three astronauts into the sky. Not until the rocket reached the top of the launch tower, some 400 feet into its journey, did the first sound of the engines reach the press site (about 3.5 miles from the pad). Everything looked good. The booster engine cutoff came at 151 seconds into the flight, exactly on time. Two seconds later, the second stage ignited. It remained visible from the ground for almost a minute after ignition, while the rocket climbed 50 miles and continued out over the Atlantic. The flight of Apollo 8, America's most ambitious space flight to date, was off to a good start, and attention shifted to the Manned Spacecraft Center in Houston which directed the remainder of the mission.

The performance of the Saturn V booster was nominal, and a satisfactory Earth orbit was achieved. During the first orbit, the spacecraft systems were carefully checked out, tank pressures were monitored, the guidance and navigation

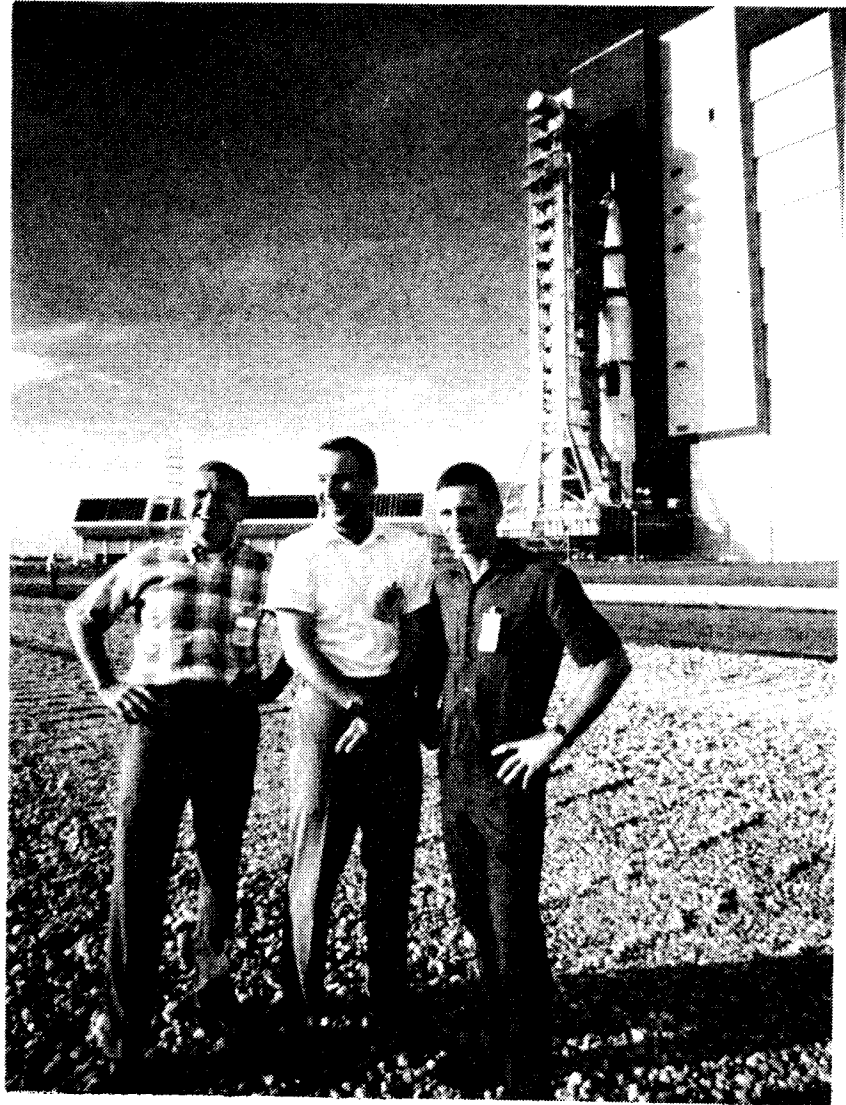

NASA Photo

The Apollo 8 prime crew of (left to right) Astronauts Frank Borman, Commander; James Lovell, Jr., command module pilot; and William Anders, lunar module pilot, stand in the foreground as the Apollo 8 vehicle leaves the Vehicle Assembly Building on its way to Launch Complex 39.

system was realigned, and the vehicle was certified as fit for a lunar flight.

Astronaut Mike Collins, the Capsule Communicator at Mission Control in Houston, reported to the spacecraft that they were go for the Translunar Injection burn (TLI) which would send the spacecraft on its way to the Moon. Borman, the Spacecraft Commander, replied with a very

calm "Roger", and the world's first manned flight to the Moon began. Two weeks earlier, Astronaut Borman, when asked to comment on the significance of Apollo 8, had said: "I think it's pretty fantastic that we're sitting here even talking about this mission." But the time for talk had ended, and as Apollo 8 passed over Hawaii on its second orbit of the Earth, the S-IVB stage,



still attached to the Command and Service Modules (CSM), was re-started. The engine burned for 5 minutes, and the speed of Apollo 8 was increased from orbital velocity to 24,200 mph. At this point, Apollo 8 was on a course which, without further correction, would carry it to within 100 miles of the Moon and then return it to Earth for a landing in the mid-Pacific.

The first and only major deviation from the flight plan came just after separation of the S-IVB from the CSM. A LOX venting from the S-IVB after separation failed to increase the relative velocity enough to assure adequate separation between the S-IVB and the CSM. In order to avoid the possibility of a collision during the later maneuvers, an unscheduled 7-second burn of the spacecraft reaction control system (RCS) was initiated. This burn altered the near-perfect flight path of the vehicle, making a later midcourse correction with the large Service Propulsion System (SPS) engine necessary.

Unlike previous manned space missions, the period of peak crew activity on Apollo 8 came in the middle of the flight. At 69 hours into the mission, Borman was authorized to fire the SPS engine when the spacecraft went behind the Moon. This SPS burn was designed to place Apollo 8 in a 60 by 160 nautical mile orbit around the Moon. Since the burn was to take place on the back side of the Moon, no direct radio or visual confirmation of the burn was possible. For 15 minutes, the crowd in Mission Control sat waiting for re-acquisition of signal and word from Apollo 8 confirming that a lunar orbit had

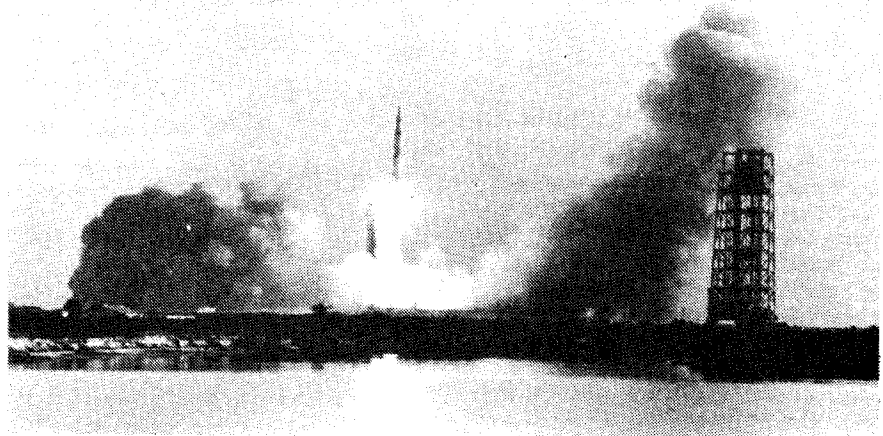

The liftoff of the first manned Saturn V vehicle occurred at 7:51 AM (EST) from the Kennedy Space Center.

Photo by William Spies

been achieved. Then the word came: "Burn complete....Our orbit is 160.9 by 60.5."

Soon afterwards came a description of the surface of the Moon, as seen for the first time by Man from a distance of only 60 miles above the surface. Bill Anders reported: "The Moon is essentially gray, no color. Looks like plaster of paris or a sort of grayish deep sand. We can see quite a bit of detail. The Sea of Fertility doesn't stand out as well here as it does back on Earth.

There's not as much contrast between that and the surrounding craters. The craters are all rounded off."

The remainder of Apollo 8's day in orbit around the Moon was spent in observing and photographing the lunar surface. The intent of these exercises was to determine how well men can guide a spacecraft to a landing in a selected location. The Apollo 8 crew demonstrated their ability to visually identify and accurately locate landmarks on

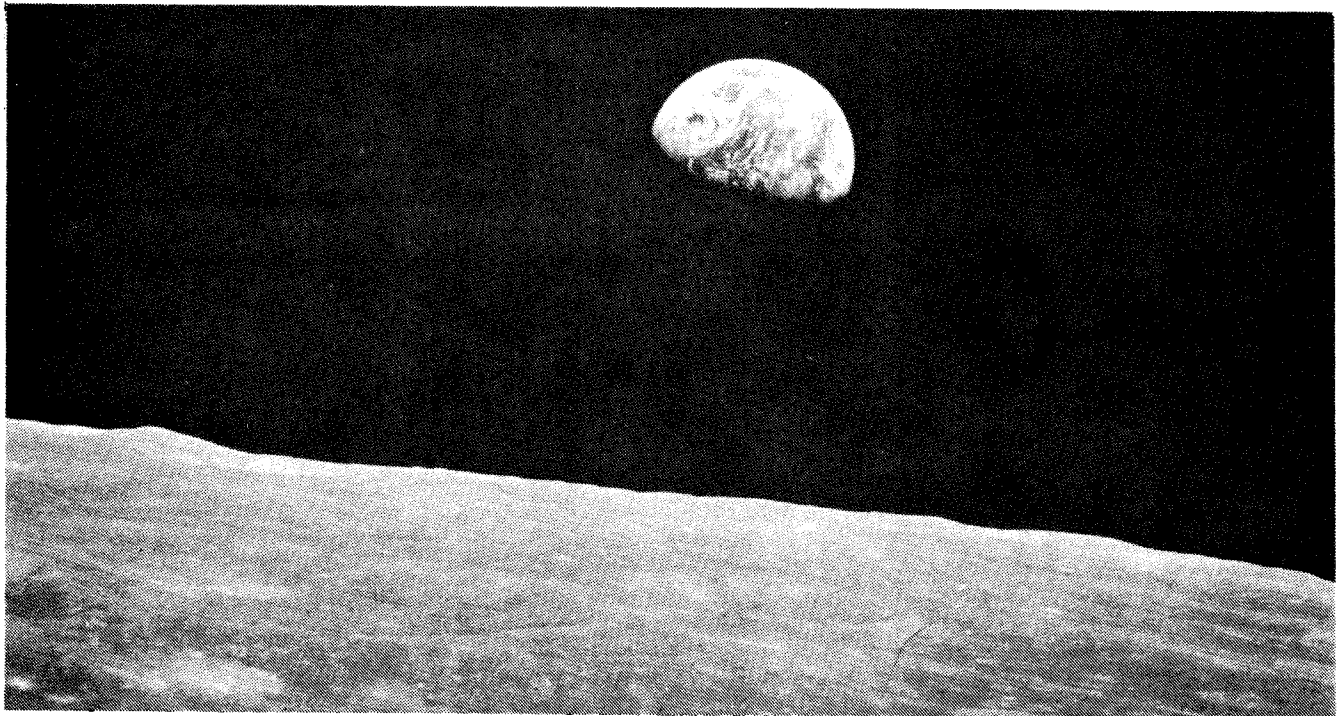

NASA Photo

This view of the rising earth greeted the Apollo 8 astronauts as they came from behind the moon after the lunar orbit insertion burn. The eastern limb of the moon is visible, and the earth sunset terminator bisects Africa.

the lunar surface. They also photographed the two potential Apollo landing sites in the Sea of Tranquility under lighting conditions similar to those expected for the first lunar landing.

Perhaps the most crucial of all maneuvers during the flight of Apollo 8 was the Transearth Injection (TEI) burn. This firing of the spacecraft SPS engine allowed Apollo 8 to break free of the lunar gravitational field and return to Earth. A failure of this system would have left the astronauts stranded in orbit around the Moon. Chris Kraft, Director of Flight Operations, called the TEI maneuver one of the three most apprehensive periods in the American space program. He compared it with Glenn's reentry, when there was reason to believe that the heat shield had fallen off, and the momentary loss of control of Gemini 8 as the spacecraft spun wildly under the thrust of a jammed RCS engine. Then he said: "This one (the TEI burn) tops them all."

The TEI burn took place while the spacecraft was behind the Moon. Just prior to loss of signal on the last scheduled orbit, Houston relayed to the spacecraft, "3 minutes to LOS, all systems go." The reply came from Apollo 8, "Roger."

Minutes passed. The time for initiation of the TEI burn came. A successful firing of the SPS engine would speed up the spacecraft and advance the acquisition of its signal by about 9 minutes from that predicted if the orbit continued. In the last few minutes before the predicted acquisition of signal (AOS), the tension increased.

However, right on time, the 85-foot dish antenna in Canarvon, Australia, confirmed reception of radio signals from the spacecraft. Several attempts were made to raise the spacecraft on voice communication links. The Capsule Communicator gave a call: "Apollo 8, Houston," at AOS plus one minute. Again at AOS plus 2 and AOS plus 3 calls went out. Finally, over a lot of static, a reply was received from Apollo 8 at AOS plus 5 minutes and 40 seconds. Borman confirmed what everyone already knew when the telemetry signals were received right on time - that Astronauts Borman, Lovell, and Anders were safely on their way home.

A small midcourse correction of 4 feet per second was made as the spacecraft fell towards the Earth. Landing occurred in the mid-Pacific before the local sunrise, and the astronauts were advised to each take a seasickness pill since no attempt at recovery would be made until dawn. In a fitting tribute to the perfection of the mission, the landing, 6500 yards from the aircraft carrier USS Yorktown, was closer to the prime recovery ship than reporters were permitted to approach the rocket during launch operations. The spectacular flight of Apollo 8, successful to the point of perfection, has paved the way for a manned landing on the Moon by mid-summer of this year.

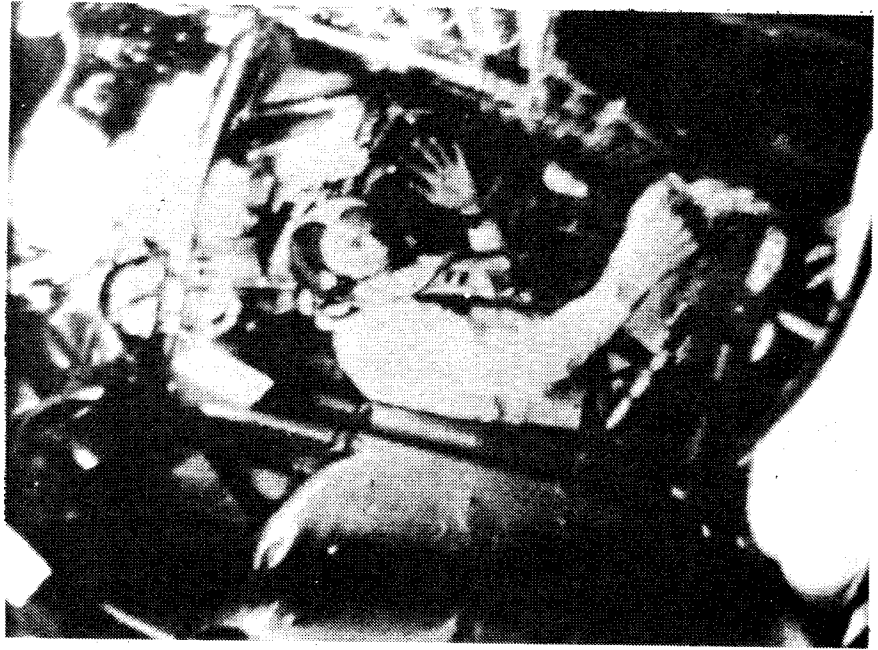

NASA Photo  
Astronaut Borman waves at the TV camera during the first live transmission from Apollo 8 on its way to the moon.

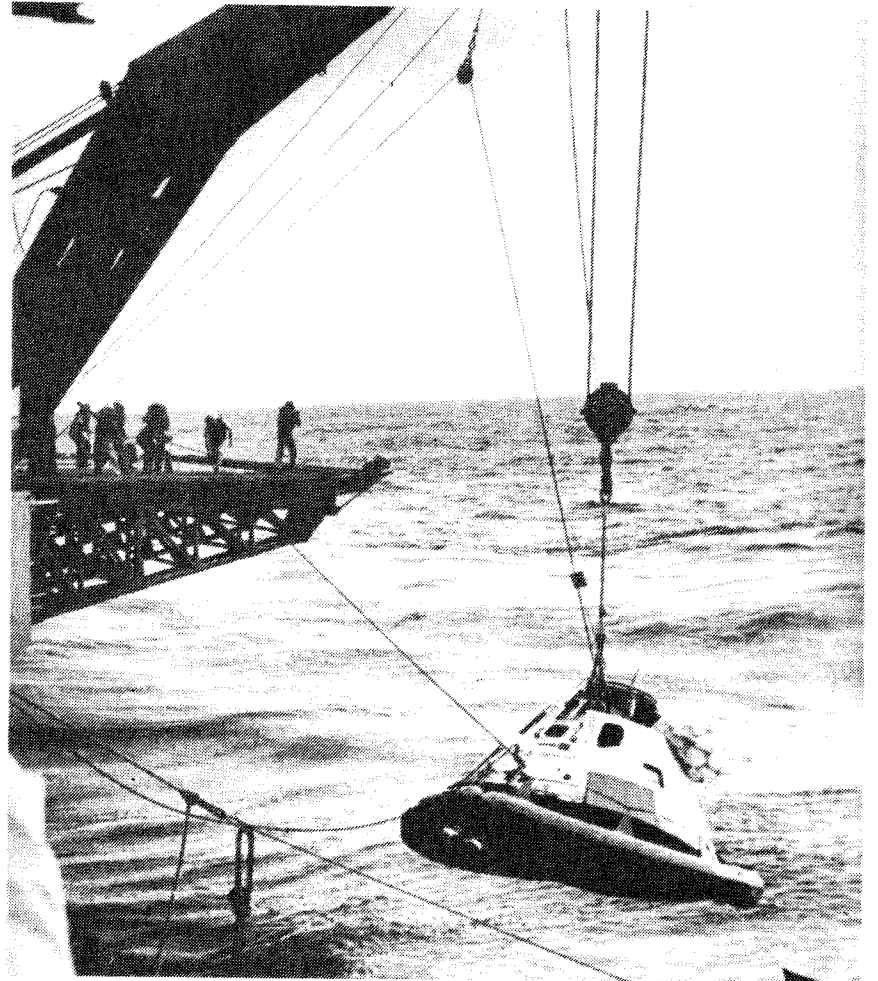

NASA Photo  
The Apollo 8 spacecraft clears the water as it is hoisted aboard the U.S.S. Yorktown some 1,000 miles South, Southeast of Hawaii.

# TECHNICAL

# NOTES

GEORGE CAPORASO

This month's tirade will deal exclusively with the need for more sophisticated payloads and instrumentation in model rocketry.

In the past, there have been such notable achievements as flights with single shot and motion picture cameras as well as telemetry transmitters. Although these were high level accomplishments and were made relatively long ago, only the single-picture camera has been widely used, albeit it is reasonably expensive to send up a motion picture camera.

The transmitters are a different story; a good one can be built for \$10 and can be

used with citizen's band transceivers. Although several good designs exist and have been published, no manufacturer has as yet undertaken their production, although interest in this field is high.

A small, efficient transmitter would make possible the airborne measurement of atmospheric temperature and pressure and could monitor stresses, roll rate, acceleration, drag, and in general, the status on any system on the rocket itself.

As we also brought out at the M.I.T. convention last spring, it is also vital that suitable ground support equipment be available at low cost, i.e., a chart recorder with

an extremely fast reaction time and chart speed, portable tape recorder and of course, receiving equipment. Unfortunately, chart recorders with a response time sufficient to permit data recording during the short duration of a model rocket flight is very difficult to build at home. Commercially available chart recorders are prohibitively expensive for the average model rocketeer. Data recording on a cheap tape recorder, however, provides the response time necessary.

The telemetry field is only one side of the coin; what about *radio control*? I have seen a 5 gram remote control receiver about the size of a die-cube. Why don't we have hordes of R/C boost/gliders terrorizing the model airplane people?

An utterly massive variety of miniature electronic components are currently available on the market; let's go to work and use them!

The ten second "steam machines" from FSI may open up some new possibilities for *guidance*—either onboard inertial or ground directed. So don't just sit there reading, *do something*, and don't keep it a secret. Write us about it and we'll give it some circulation.

Regarding aerial photography, the author hopes to launch a Bolex 8, 8mm. motion picture camera in the winter or early spring of 1969 and full details will be reported in *Model Rocketry*.

Remember, if you have any question or comments about this column or the topics of discussion presented therein, please write to TECHNICAL NOTES, George Caporaso, Model Rocketry, Box 214, Boston Mass. 02123.



## MODEL ROCKET KITS AND ACCESSORIES

### OTHER KITS AVAILABLE:

ASTRO-QUEST  
ALPHA-1  
ALPHA-B  
SWIFT  
SPARTAN  
AJAX

KIT PRICES RANGE FROM  
\$1.50 - \$2.00

### ALL KITS FEATURE:

- HARDWOOD NOSECONES
- EASY TO FOLLOW INSTRUCTIONS
- PROVEN & TESTED DESIGNS
- NEW & DIFFERENT

### ALSO AVAILABLE:

PLASTIC NOSECONES PLAIN  
& CHROME-PLATED

DEALERS' INQUIRIES WELCOMED  
WRITE FOR MORE INFORMATION  
TO.....

### PHOENIX



- EASY TO BUILD
- 21 INCHES LONG
- HIGH PERFORMANCE

\$ 2 00



DEVELOPMENT COMPANY, INC.  
BOX 247, LIVERPOOL, NEW YORK - 13088

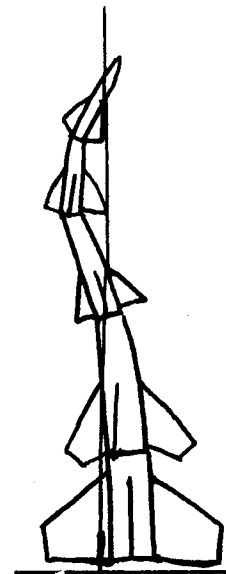

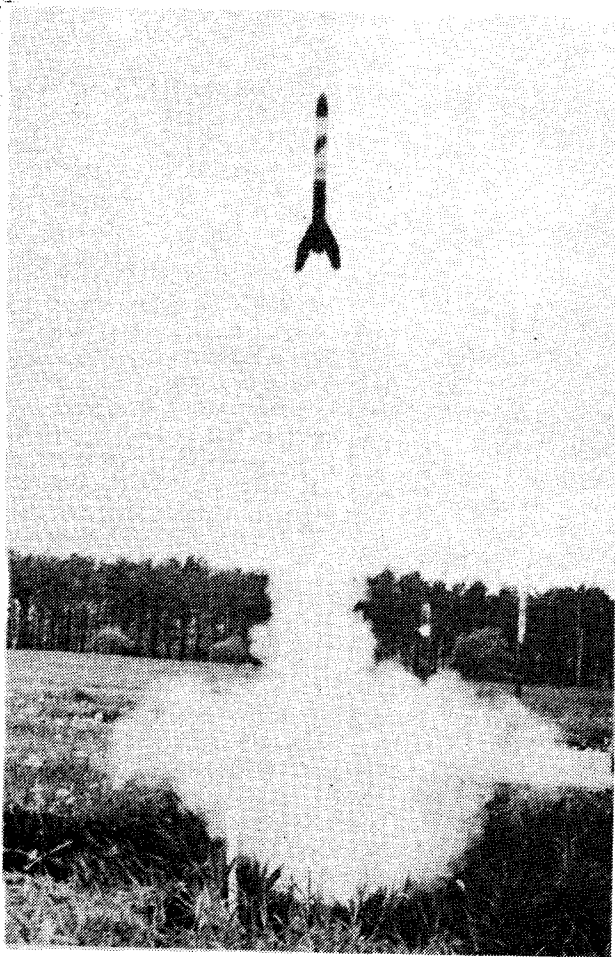

# PHOTO

# GALLERY

*Readers are invited to submit photographs of their model rockets for publication on this page. Our staff will select those photographs having superior quality and composition for inclusion in the Model Rocketry Photo Gallery. Send your photos to:*

*Photo Gallery  
Model Rocketry  
Box 214  
Boston, Mass. 02123*

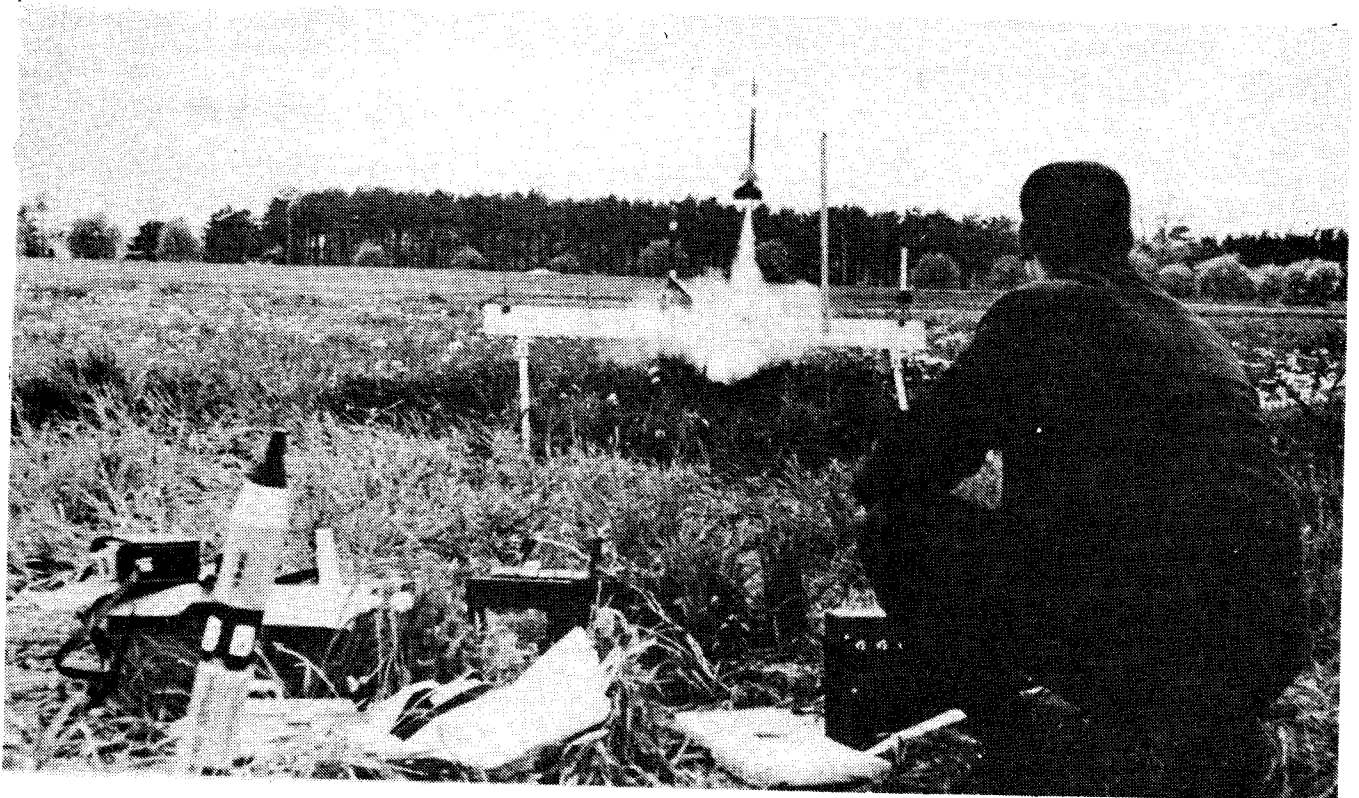

# The Old Rocketeer

by G. Harry Stine NAR#2

*This is the first of what I hope will be a regular, continuing series of articles in Model Rocketry magazine. Some of you may have followed the "Rocket Trails" and "Count Down" departments in American Modeler magazine where my exhortations, gripes, designs, reports, criticisms, witticisms, and tantalizing tidbits have appeared off and on for the past decade. And this department will just go on from there - perhaps a little bit saltier because I am now addressing an audience that is 100% model rocketeer and very much with it.*

*I will NOT go basic-basic on you because I think that you, dear reader, are more than just a raw beginner. Otherwise, you would not be reading this. Howsomer, if you are a beginner, you can find all sorts of data, information, plans, etc. ready and waiting for you from the model rocket manufacturers. Plus the fact that I've gone to considerable trouble to write all the basic stuff down and get it published in The*

**Handbook of Model Rocketry**, by Follett Publishing Company, Chicago, Ill. (adv.).

*Why am I submitting my stuff to this magazine now instead of one of the bigger modelling magazines with larger circulation? Because I sincerely believe that it is high time that we model rocketeers had our own magazine. And because I sincerely believe this, I am giving my full support to Model Rocketry. I am also giving my support to this magazine because it is being published by a group of model rocketeers as a private, profit-making venture under the capitalistic free enterprise system. I think that this system works pretty well on the basis of comparing free enterprise model rocketry in the U.S.A. against model rocketry as conducted under other economic systems ... and I am intimately familiar with this sort of thing by virtue of my position of Chairman of the Rocketry Subcommittee, Commission Internationale d'Aeromodelisme (C.I.A.M.).*

*As to the regular contents of this department, I don't promise anything other than that I will try to keep it interesting, informative, and otherwise generally in. Being a very sneaky character, I may sneak some sneaky stuff in from time to time. You'll never know what's going to happen next. In some cases, neither will I.*

## WHO ARE THE MANUFACTURERS?

What kind of men lead our American model rocket manufacturing firms? What particular talents and training lie behind the huge assortment of kits, motors, parts, and accessories of the U.S. model rocket industry? Let's look at the men, one by one.

Vernon David Estes, President of Estes Industries, Inc. is one of the true model rocket pioneers. Vern is NAR No. 380. In 1958, he had his own home construction business in Denver, Colorado. He approached the now-defunct Model Missiles, Inc. in July 1958 and offered to replace their hand-made model rocket motor supply with a source of motors made entirely by automatic machinery. When asked what he knew about this, Vern replied, "Not much, but I intend to learn." This he did. By January 1959, Vern had designed and built "Mable," the world's first fully-automated model rocket motor machine. Mable has now retired after making well over 10,000,000 model rocket motors.

In 1960, Vern's motor making capability exceeded the requirements of Model Missiles, Inc., so he started his own mail-order model rocket business. His first kit was the Astron Scout, followed shortly by the Astron Mark which I designed for him. His 1961 catalog was mimeographed and stitched together on his wife's sewing



Seen at NARAM-9 in Mankato, Minnesota, were (left to right) Larry Loos, editor of the NAR's "Model Rocketeer;" Leroy Piester of Centuri Engineering Company; George E. Roos of Flight Systems, Inc.; and official NAR photographer Tommy Pastrick.

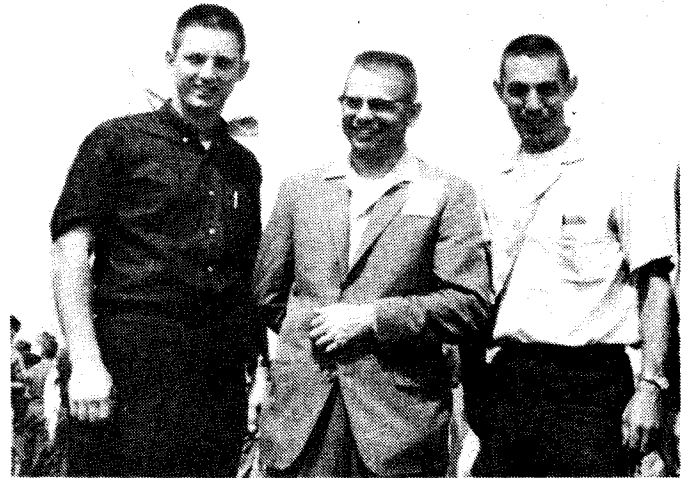

Photos by Stine  
The manufacturers (left to right) Leroy E. Piester of Centuri Engineering Company; Vernon D. Estes of Estes Industries, Inc., and Irving S. Wait of Rocket Development Corporation.

machine.

By 1962, Vern's operation had grown too large to continue in the restricted confines of Denver. He needed open land. So he bought an old farm in Penrose, Colorado and moved his entire operation there shortly after NARAM-3. Today, Estes Industries, Inc. has grown to be the largest model rocket manufacturing firm in the world, employing nearly 100 people in over 30,000 square feet of factory space. The rest you know about.

A largely self-educated man, Vern has attended the University of Denver and the University of Colorado to pick up courses in science, engineering and business to assist him in managing his firm. He is a true Yankee gadgeteer in the classical sense, having designed and built most of the automatic machines used by Estes Industries, Inc. to make motors (he now has 5 motor machines on the line), nose cones, igniters, etc. The ultimate bit of Vern Estes' engineering is his machine that coats toilet tissue rolls with a flame-resistant chemical to make his famous flame-proof wadding. Can you imagine the problems of engineering a machine to handle wet toilet tissue without tearing it?

Leroy E. Piester, President of Centuri Engineering Company, is an industrial engineer with a background in business administration. His college thesis was the design of the factory to make, store, package, and ship Centuri's model rocket products. Leroy began as an amateur rocketeer, and his early designs for large experimental rockets were tagged "Centuri" because this was a null-word with astronomical overtones. He came into model rocketry by virtue of a visit to the Third National Model Rocket Championships (NARAM-3) held at Hogback Rocket Range near Denver in 1961. He left convinced that model rocketry was the business for him, and Centuri Engineering Company was set up in his garage in Phoenix shortly thereafter. Now, Centuri has grown to fill a large modern factory building in Phoenix as well as outlying motor making facilities. Leroy is also a gadgeteer who designs all of the Centuri machinery for automatically making parts, and he also has designed almost all of the Centuri model rocket kits and accessories.

Irving S. Wait, President of Rocket Development Corporation, has a background as a professional rocket engineer specializing in solid propellant rockets, design and development of rocket motors, and ballistic analysis. Before organizing RDC in Utah in 1961, Irv was professionally employed by Thiokol Chemical Corporation and worked on the Minuteman and Polaris projects. In 1963, Irv moved RDC to the open spaces of a farm near Seymour, Indiana for the same reason that Estes sought open space: making rocket equipment requires this open space and is

difficult to carry out in a heavily populated area. Irv's products include the Enerjet motors, the only ones at this writing that use a modern composite solid propellant with a specific impulse of more than 100 pound-seconds-per-pound. Because of his professional background, Irv's major activities with RDC involve solid propellant rocket motors. Beyond the model rocket limits, Irv has built and tested some very large motors - by our standards - which are currently finding their way into use as propulsion for inexpensive, medium performance rockets.

Another professional rocket engineer heads up Flight Systems, Inc. out in Louisville, Colo. George E. Roos has been professionally employed with Thiokol and other aerospace firms as a chemical engineer specializing in solid propellant development. He's also been a chief engineer, a director of research, a project engineer, and a technical manager for some of our nation's missile and space programs. Under George's direction, FSI not only makes model rocket kits, motors and accessories, but is currently engaged in rocket projects for commercial and scientific use - rocket systems for weather modification, cloud seeding, and atmospheric sampling, to name a few. Some of George's development's include a method of releasing a chemical from a small rocket at 1500 feet to determine the source of air pollution.

A new firm in the model rocket business whose products are found only in hobby shops, Model Rocket Industries is headed by the team of Myron Bergenske and Ron Day. "Mike" Bergenske is studying for his Doctorate in Astronomy at the University of Wisconsin and specializes in the study of magnetic field effects on stellar structure. Mike launched his first home-made rockets in 1949 and became a model rocketeer as soon as the first kits and motors became available from Model Missiles, Inc. in 1958. He handles all of the research and development for MRI while his partner, Ron Day, handles production, Management and merchandising. Ron is another old-time model rocketeer who has been building and flying all sorts of models all his life.

At the present moment, these are the men who are America's model rocket industry. They are all highly-qualified technical and scientific men, gadgeteers, and persons with experience in modelling and rocketry. *They are all model rocketeers.* In addition, they have a lot of business sense because it is not easy to make a success out of the commercial end of model rocketry. It's no road to riches because each of these men believes that it is absolutely necessary to put profits back into their businesses for continual research and development, for educational purposes, and for constantly improving the quality of their products. Unlike many other hobby industry areas, model rocketry isn't the sort of thing that

can be operated out of a basement as a commercial venture - at least not these days.

Since I personally know all of these men, I can also add that they are totally devoted to the basic ethics and philosophy of safe, educational and enjoyable model rocketry espoused by the NAR. We're very fortunate to have men like these heading the firms in model rocketry.

---

## Book Review

### Model Spacecraft Construction

Model Spacecraft Construction, National Aeronautics and Space Administration, 1966, 184 pages, illustrated, \$1.00.

This booklet was prepared for use in high school industrial arts and aerospace education courses. It consists of twelve sets of construction plans for scale display models of satellites and launch vehicles. Since the scale data presented was taken from plans supplied by NASA it can be used for scale substantiation as required by NAR contest rules.

The booklet contains scale plans for the following:

- Saturn V
- Explorer XII
- Orbiting Solar Observatory
- Relay I
- Mariner
- Apollo Command Module
- X-15 Rocket Plane
- Titan II (Gemini Launch Vehicle)
- Gemini
- Tiros
- Orbiting Astronautical Observatory
- Apollo Lunar Module

Those of particular interest to model rocketeers are the Saturn V and Titan II and X-15 plans. These contain sufficient detail to allow construction of a scale model without additional research.

For each design, a photograph and exploded view of the rocket are provided. This is followed by a parts list as well as several pages of detailed drawings and a recommended construction procedure. Detailed historical information is also given for each model.

This booklet, a valuable addition to the bookshelf of a model rocketeer, is available for \$1.00 postpaid, from the Superintendent of Documents, U.S. Government Printing Office, Washington D.C., 20402. Order Document number 0-741-996.

GJF

# Model Rocketry for the Depraved

by Joel S. Davis

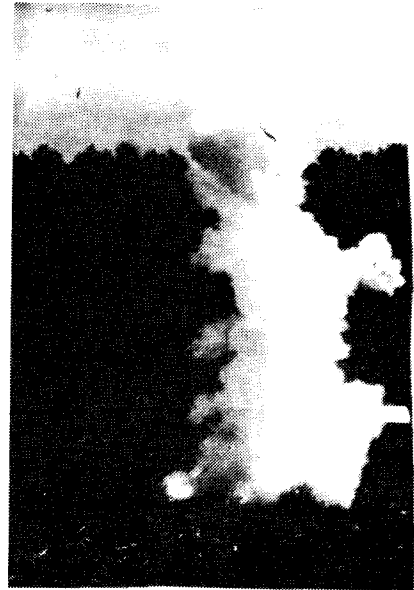

*The following is a disclaimer by the author: "I hereby disclaim any responsibility for the contents of this article, and if forced to testify, am prepared to swear that none of the following text was ever written by myself or any other human being." Model Rocketry magazine is not responsible for the psychotic ravings of the author. Any resemblance to actual places or events, or to actual persons, living or dead, is purely coincidental.*

I always enjoy watching the budding new rocketeers that seem to constitute the next generation industriously working on rockets that can only be described as works of art. Edges sanded fine...exquisite paint jobs...every measurement perfect. Why do they go to all this trouble, I ask myself. When I ask, I don't get very good answers. "It will go higher," they say, or "it's prettier this way." I don't believe it. Sometimes I suspect that they get some fiendish pleasure from fondling paint brushes and sandpaper, but when I see the hopeful, innocent looks of purity on their shining faces, I can't really believe it for long. Hence, I'm forced to assume that it's merely a matter of simple ignorance.

Let's face it. You build a rocket for essentially one thing— you want to see the fire and smoke, hear the woosh of rockets (a poor substitute for a roar, but it will do for amateurs), and receive the admiration of your friends when they watch a successful flight. All a good paint job does is get ruined when your rocket lands in the only mud puddle for two miles or lands in the only unclimbable tree in the area—right before a rainstorm in which the tree gets struck by lightning.

But, if you accept the truth about model rocketry...then, you can really have fun. First, you must penetrate the "great design

fallacy". The essence of it is that good design and care in construction are significant factors. **BALDERDASH!!!**

Admittedly, you can't totally foul things up and still expect good results. Your nosecone should have some excuse for a point; it's nice to let the glue holding your fins to the rocket dry; and, certainly, it must be stable. I'll even go so far as to admit that sanding some sort of leading edge on your fins may help. Aside from that, there isn't much to worry about.

At one NARAM I saw the world record for PeeWee payload competition broken by a rocket that was tossed together in ½ hour out of scrap parts. It had three fins...not the same size...definitely not at 120 degrees..., a blunt nosecone with a big chip out of it, and the poorest paint job you've ever seen. It did, however, fit Davis's first law—"When in doubt, use BRUTE FORCE." Anyone who uses an engine with less than the maximum number of lb-seconds allowable is a fool.

The way to win almost any contest is to decide what the particular competition is after, and construct your rocket solely to best fulfill those criteria. For example, let's pretend you're building for altitude. First, put the most powerful engine allowable into your rocket. Second, don't waste time and effort weighting down your rocket with paint, varnish, etc. Use a light coat of spray-paint to minimize the weight. Furthermore, make that rocket as small as possible...it shouldn't be much more than engine, fins and nosecone. Pick an engine with a long delay, have it come out with a short streamer (very short), and define your rocket to have a "featherweight recovery system". The reason you have a long delay is because of air friction. After the engine is finished firing, extra weight can't hurt you...it helps you, because the additional momentum helps overcome drag. Finally,

don't forget that light coat of spray paint...I've seen more rockets than I care to think about lost in tracking. No matter what you do, there's a huge luck factor involved, but there's no sense making it any worse than 80% or so.

I've seen an interesting boost glider experiment that may revolutionize the field. The idea is to have a standard sort of rocket with a hole down the axis of the nosecone. In this hole sits a ¼ inch dowel rod that constitutes the fuselage of a tiny glider, which weighs under an ounce, pops out and will spend amazing amounts of time in the air, given a large wing surface/unit weight ratio.

This should give you some idea about how to enter contest flying, but the more important aspect of model rocketry is the fun you can have on your own.

I remember a certain cluster engine rocket we had once put together...roughly similar to the commercially available COBRA. As it floated down in a little old ladies front yard (a strong wind being present that day) our observers came running after it shouting "stay away; stay away; wait for the recovery team." The resident was cowering in the living room, apparently convinced that the spectacle of a rocket coming down on a parachute outside her front picture window constituted at least a government project gone awry and, at worst, an invasion from Mars. One street urchin nearby asked if it were radioactive. We avoided answering very mysteriously but assured him that it was exceedingly dangerous. I proceeded to flash some piece of very official looking identification and assured him I was a government agent. I told him to keep the matter a big secret, in the name of national security. Then our whole team took the rocket in hand and slipped away into the nearby woods. Glorious!

That same rocket, incidentally, had sad times afterwards. After adding a cluster engine booster, we fired it from a school football field. It took off ok, but when stage separation occurred, the side of the booster blew out, tipping the whole rocket 90 degrees. It roared between two houses and executed a one-fin landing across a freshly plowed area that was someone's excuse for a garden. Fast action got the rocket back, but the owner of the property wouldn't return the fin that had been broken off in the landing.

It's been a long time since I spent very much money on rocketry. Except for engines, and some balsa fin material from time to time, I've constructed almost all my rockets from scrap parts accumulated during my first two years in model rocketry. This is not due to poverty, as one might expect, but merely to laziness. I never get up enough energy to go to the store and am too impatient and cost conscious to buy balsa in the mail. This has led to some strange-looking rockets but at the distances one normally observes their flight from, you can't really tell. And there is that satisfying trail of fire and smoke.

The main difficulty in constructing model rockets is not in design or parts, but three rarely considered factors. These are: 1. Relatives, especially younger ones. When little Tommy strolls into you work area and says "Gee, what does this do-oops"...CRUNCH!... don't you get an urge to kill? or when you're madly trying to finish a rocket for competition and your mother comes in with cousin Matilda and says, "How about showing cousin Matilda around your workshop," and cousin Matilda

can't tell a screwdriver from a nosecone? Or you suddenly find out that 2-year-old Jimmie has spilled all your white glue on the floor and has managed to permanently mount half your engines and new parts to the rug you bought to beautify the area? 2. Pets. Need I describe what happens when Fido and the pet cat go at it across your workbench? 3. Murphy's law. The essence of this law is: "If anything can go wrong, it will." Like when you order B.8-6 engines for a contest and get 1/2A boosters instead on the morning of the eagerly awaited event! Or when you buy 3 feet of fin material and find you're lacking a necessary half-inch? Or when you drive 22 miles to a contest site, and find out you've left all your rockets behind?

The classic application of this famous law occurred several years ago, at the founding of the Steel City Section of the NAR. Two weeks before it first meet, there was a demonstration meet, with all the newspapers and TV stations in the area invited...a truly gala event. Unfortunately, this demonstration took place before anyone really knew the truth about PRODYNE rocket engines. For you newcomers to the field, PRODYNE manufactured high impulse (series F, notably) engines that featured burning times of several seconds. Any given engine also had a high probability of creating a rather spectacular explosion.

I'll avoid most of the gruesome details, but leave it be said that several large rockets did violently detonate about fifty to seventy-five feet up. Page one of the second section of the Pittsburgh Press had a beautiful picture of one such explosion above

the launching area. It was taken from a high vantage point and you could see everything...the explosion itself...fragments flying in all directions...the trail of smoke down to the launching rack...and the stunned faces of the people below.

Of course, most of the section members were quite unhappy about the whole thing, but a few of us--those among us who were really sadistic--got endless pleasure of the most fiendish kind from the loud CRACK!, and the accompanying cloud of smoke and fragments.

Take it easy. If you're really as deprived as every rocketeer should be, these things won't bother you much. You can always go out and watch demolition teams at work...or take a vacation to Cape Kennedy. A Saturn takeoff will really curl your hair! Remember, that in model rocketry, it's not whether you win or lose, it's how much fire and smoke you can put into the game!

(Letters to the Editor, continued)

Articles should be typed double-spaced. Any illustrations should be done in black ink on white paper. Photographs should be accompanied by the negative (if possible). The authors of articles accepted for publication will be paid at our standard rates.

#### Dragstab II

You have made a great start in getting Model Rocketry started professionally. The mag is great! I hope you can keep it going.

In reference to the Dragstab in the October issue, try this:

## q & a

How far away from the launcher should a tracker be?

S.S.  
Levittown, Pennsylvania

The optimum distance for visibility (even for just watching a launch) is about equal to the expected height of the flight. When using an altitude tracking scope this rule also applies. However, if your scope magnifies, the distance should be farther away. This makes it easier to follow the rocket up. For accuracy in tracking, one should avoid having to look at an angle to the ground (elevation) that is close to 90 degrees.

I am using alligator clips on my launcher and have a problem with the clips slipping off the fine nichrome wire in Sure-shot and Ignitrite igniters.

H.C.  
Brooklyn, N.Y.

Alligator clips are designed to grip with rows of sheet-metal teeth. These teeth cannot grip fine wire and are difficult to keep clean. For this reason, most launch systems are built using micro-clips, which are just flat metal with no teeth. Alligator clips can be used if the jaws are filled with solder, then filed flat. The soft solder can actually grip better, and can be cleaned faster with an emery cloth or piece of sandpaper. A package of small leads with alligator clips on both ends can be bought very inexpensively at a radio-electronics supply store. These can be used for clip whips in cluster ignition.

Any questions submitted to this column and accompanied by a self-addressed, stamped envelope will be personally answered. Questions of general interest will also be answered through this column. All questions should be submitted to:

Q and A  
MODEL ROCKETRY MAGAZINE  
Box 214  
Boston, Mass. 02123

6" of 0.710" tube

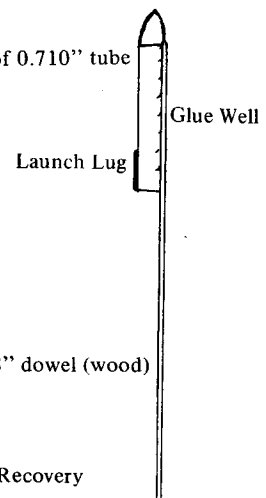

Streamer Recovery

Any Engine from 1/4A to B14

It's much simpler, but don't launch it in high winds. The design works real well, I've tried it. A five-foot launch rod should be used.

Kerry Jones  
Kokomo, Ind.



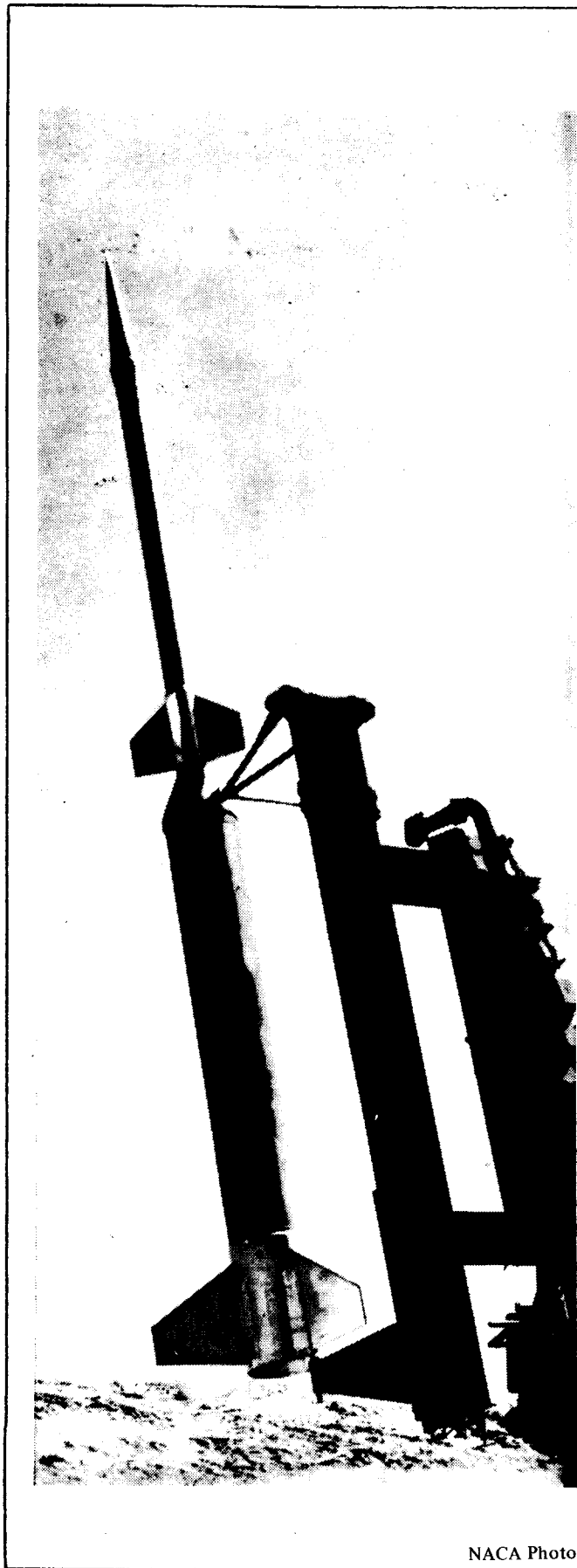

NACA Photo

### Nike-Deacon Specifications

*Scale*

Two-stage, solid fuel sounding rocket.

Length: 306 inches

Diameter first stage: 16.5 inches

second stage: 6.25

Weight: 1540 lbs.

Payload: 30-35 lbs.

Altitude: over 350,000 ft.

**Ni**

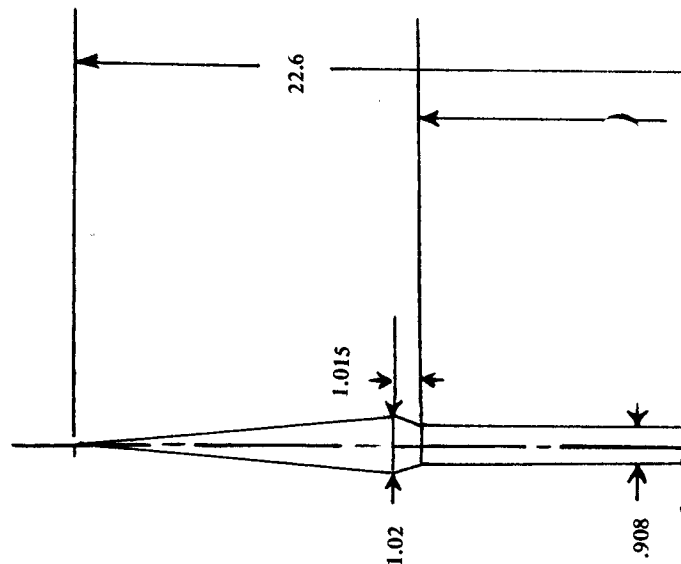

# Design: Nike-Deacon

The Deacon rocket project was initiated by the National Defense Research Council during World War II. This rocket was designed to carry a 30 pound payload to about 12 miles. In this configuration, the rocket was used for upper atmosphere research at the conclusion of the war.

However, the Deacon was more frequently employed in the Rockoon configuration. The Deacon was carried into the stratosphere below a large balloon. Only when the rocket was above the dense layers of the atmosphere, and the effect of air drag on the rocket was negligible, was the Deacon solid fuel engine ignited. In this manner, the Deacon could carry its 30 pound payload to altitudes of over 65 miles.

When the Nike military booster (the first stage of the Nike-Ajax) became available, the Deacon was employed as the upper-stage for a 2 stage Nike-Deacon sounding rocket. Two of these rockets were fired from the Wallops Island launching site during 1955. The first one, fired at a launch angle of 75°, carried a 34 pound payload to 67.4 miles. Later in the year, a second rocket carried 39 pounds to 66.3 miles.

Soon after these flights, the Deacon was superseded by the more modern Cajun rocket. The Cajun, though very similar to the Deacon in outward appearance, uses a solid fuel with higher specific impulse. The first Nike-Cajun fired from Wallops Island on July 6, 1956, carried 51.5 pounds to 80.7 miles.

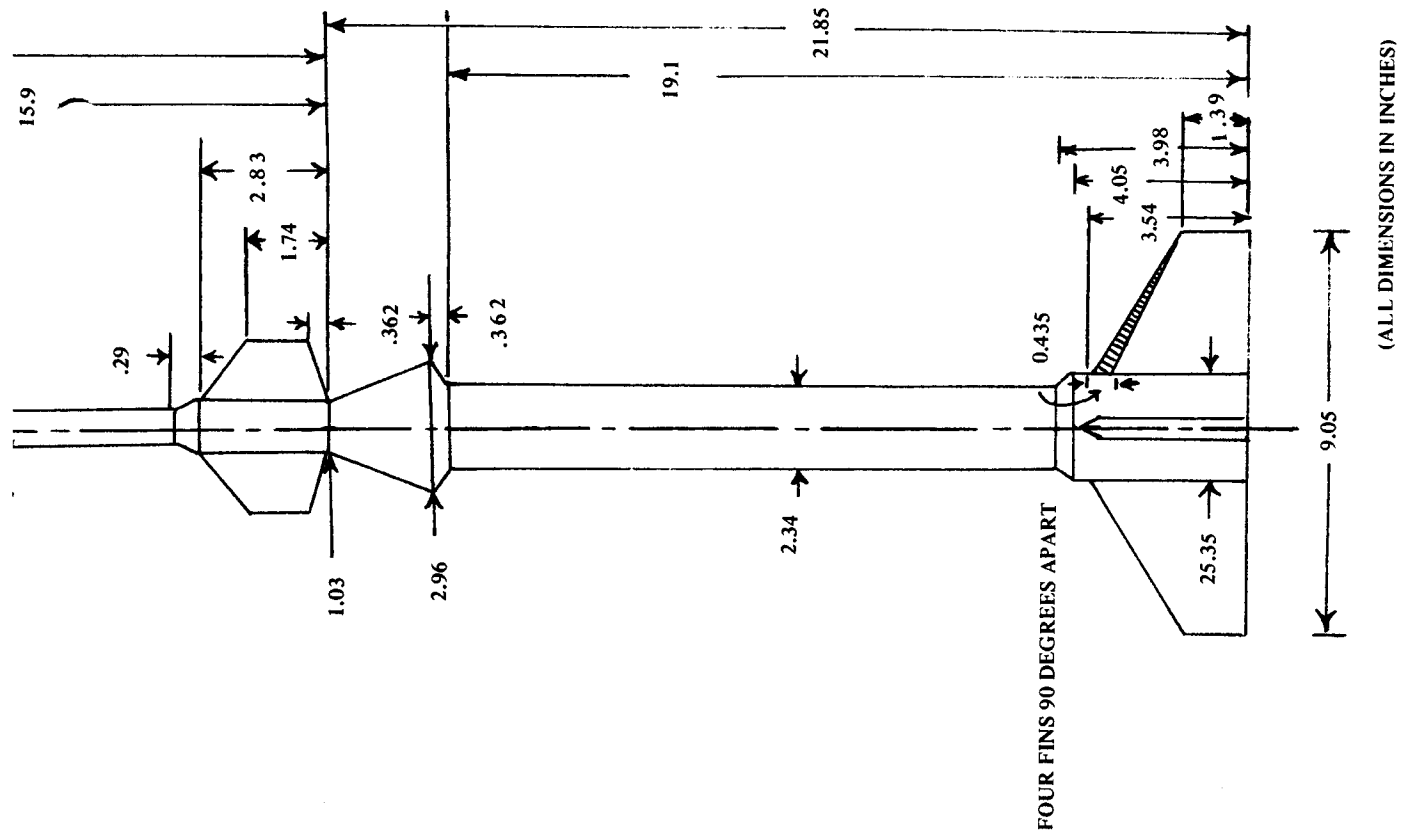

## \$5000 Model Rocket Facility For Los Angeles

Model rocketry may soon become legal within the city of Los Angeles. If this situation does materialize it will be a result of efforts started in late 1967 to incorporate model rocketry into the aeromodeling activities already taking place at the Los Angeles Model Airport near Van Nuys, Calif. The prospective launch site is the Sepulveda Flood Control Basin located between the Ventura and San Diego Freeways and has been in use by modelers for the past

20 years.

As part of a \$75,000 proposal to the city Parks and Recreation Dept., modelers would have permanent flying areas within Los Angeles. A \$5,000 model rocket facility would be included in the package to be completed in the next few years. This would be perhaps the first permanent and locally subsidized model rocket site in the United States.

The Southland Section of the NAR was

invited to participate in a demonstration of model aviation at the Sepulveda Basin. They put on a launching display for the benefit of city officials to acquaint them with the safety and educational value of model rocketry.

If all goes well, active groups in the Los Angeles area will be able to legally fire model rockets without traveling inconvenient distances to a site. California is finally recognizing the true value of model rocketry. We hope that progress will continue towards this end.

### SOLICITATION OF MATERIAL

In order to broaden and diversify its coverage of the hobby, **MODEL ROCKETRY** is soliciting written material from the qualified modeling public. Articles of a technical nature, research reports, articles on constructing and flying sport and competition models, scale projects, and material relating to full-scale spaceflight will be considered for publication under the following terms:

1. Authors will be paid for material accepted for publication at the rate of two dollars (\$2.00) per column inch, based on a column of eight-point type thirteen picas wide, for text, six dollars fifty cents (\$6.50) for drawings, and two dollars (\$2.00) for photographs accompanying text. Payment will be made at the time of publication.

2. Material submitted must be typewritten, double-spaced, on 8½ by 11 inch paper with reasonable margins. Drawings must be done in India ink and must be neat and legible. We cannot assume responsibility for material lost or damaged in processing; however our staff will exercise care in the handling of all submitted material. An author may have his manuscript returned after use by including a stamped, self-addressed envelope with his material.

3. Our staff reserves the right to edit material in order to improve grammar and composition. Payment for material will be based on the edited copy as it appears in print. Authors will be given full credit for published material. **MODEL ROCKETRY** will hold copyright on all material accepted for publication.

Those wishing to submit material should send it to:

Editor

Model Rocketry Magazine

P.O. Box 214

Boston, Mass., 02123

# Model Rocket Carries Movie Camera

Another successful attempt to carry a commercial movie camera aloft aboard a model rocket was reported in a recent issue of *Modern Photography*. Evan Ravitz, of Croton-on-Hudson, New York, launched a Kodak M14 super 8 movie camera weighing 14 oz. The carrier rocket was a single stage Centuri Hustler.

The movie camera was pointed straight up and taped securely to the nose cone. A mirror was fastened at an angle above the camera in order to provide a view of the ground during liftoff. The camera's electric eye was used to compensate for changing light conditions during the flight.

Just before launch the camera was set for continuous run. On the first flight the camera was carried to over 600 feet before the parachute opened. Several of the neighborhood children ran to catch the payload as it drifted to the ground. They

failed, but the camera survived the landing.

A *Modern Photography* editor, Myron A. Matzkin, who viewed the films from the first flight commented: "The processed film was slightly on the wild side. If nothing else it imaged the extremely rapid acceleration of the flight. Footage also shot on the way down showed ground detail—albeit a bit on the seasickness-inducing side."

A second flight of the camera-carrying rocket was somewhat less successful. The ejection charge burned a hole in the parachute, and the rocket crashed. The camera was damaged on landing, but Ravitz was not discouraged. He plans another flight as soon as the camera is back from the repairman. He also plans to modify the camera to operate at a faster film speed, since the standard shutter speed is not fast enough to provide sharp images during powered flight.

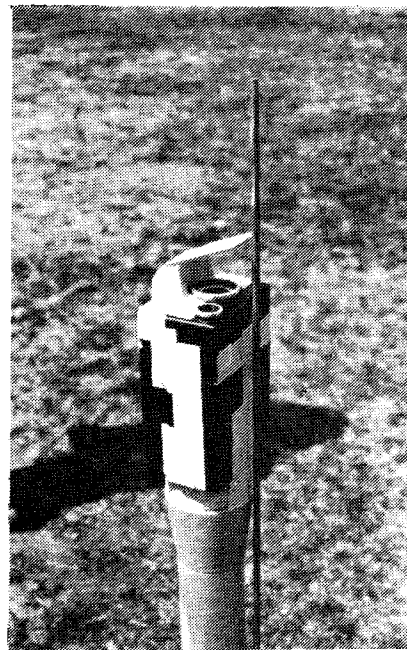

The Kodak M-14 movie camera was securely taped to the body tube.



The final launch preparations included adjustment of the angle of the mirror.

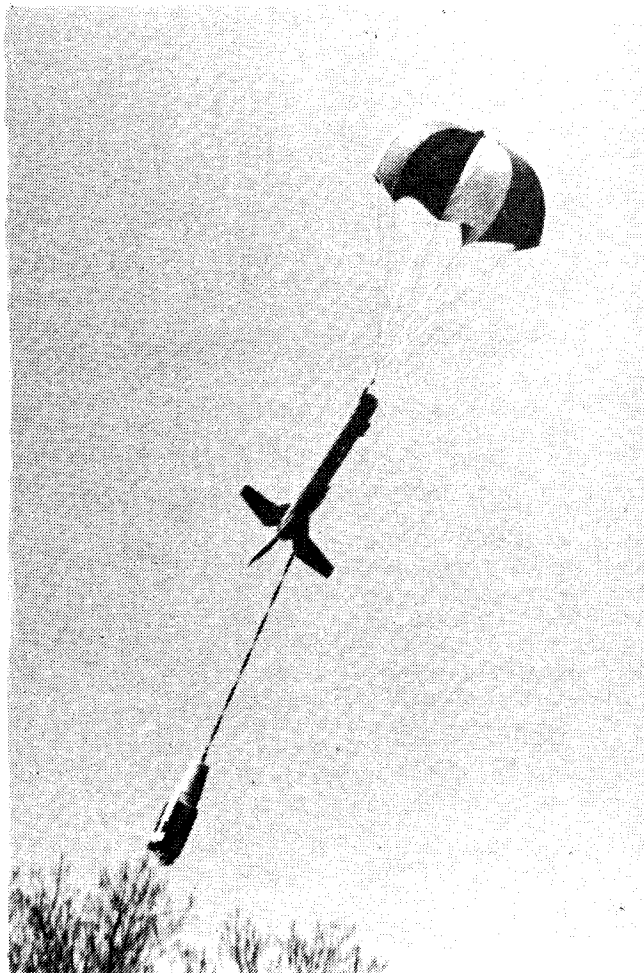

Photos by Myron A. Matzkin  
Movie camera swings beneath parachute as the rocket returns to earth.

12" PARACHUTE

4 Balsa FINS

ALL DIMENSIONS ARE  
GIVEN IN INCHES

SCALE: 1 INCH = 1 CM.

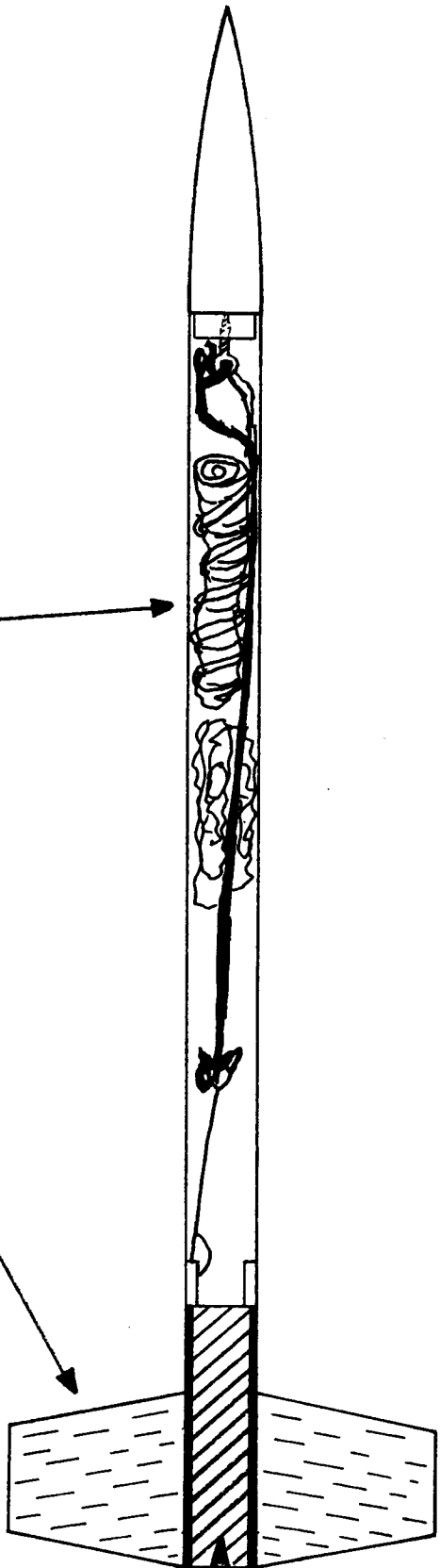

4.4

18

.5

1.5

.5

2.5

.98

# Cosmic Avenger

## For Class E Engines

by George Caporaso

The Cosmic Avenger is a high performance, single-stage altitude rocket meant to be flown with an E class engine. The initial weight for this rocket has been optimized and its Altitude versus Drag Coefficient curve is shown in fig. 1.

The design is aesthetically appealing as well as excellent for dynamic stability and low drag. The parts list is given in fig. 2. The rocket may also be adapted for payload work by installing a payload compartment on top of the regular body.

Because of its high altitude and light weight, a streamer or partially tied 12 inch parachute should be used for recovery. The three fin design minimizes the interference and fin friction drag which are the greatest single contributors to the total drag. The parabolic nose cone is used for low pressure drag.

The fins should be cut from 3/32 inch balsa stock. Round all leading edges and taper the trailing edges. Make sure that the nose cone and fins are absolutely smooth since these areas will have the most important effect on the boundary layer and hence on the drag. Seal the nose cone and fins by dipping them in Aero-Gloss Balsa Fillercoat or in Testors' Sanding Sealer. Finish the model with spray enamel or dope, paying special attention to the nose cone and fins as mentioned previously.

Do not launch the Cosmic Avenger in moderate or high winds as a 6 second thrust time and low thrust (0.835 lb.) will allow the rocket to weathercock severely in even a moderate gust of wind. If the rocket is deflected so that the vertical component of thrust will no longer support the weight because of the angle of attack, the rocket will nose dive—under power.

If it is desired to terrorize the population of the surrounding towns, it is possible to add a simple first stage to the Cosmic Avenger. Either the E. 835-0 or the D1.12-0 are suitable choices for boosters, again providing the wind is not too strong. If this configuration is used, do not put a payload in the rocket and do not launch the double E configuration unless there is absolutely no wind.

### PARTS LIST FOR COSMIC AVENGER

Nose Cone	Estes BNC-50Y
Body Tube	Estes BT-50
Parachute	Estes PK-12
Screw Eye	Estes SE-1
Shock Cord	Estes SC-1
Engine Block	Estes NB-50
Fin Material	Estes BFS-40
Launch Lug	Estes LL-2A
Engine	FSI E.835-6

Say you saw it in

# Model Rocketry

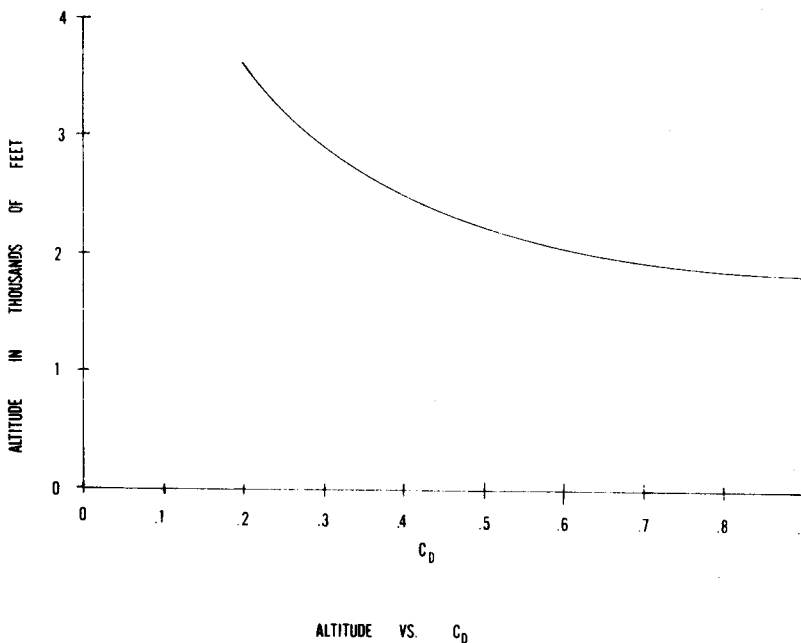

## BACK ISSUES AVAILABLE

Back issues of MODEL ROCKETRY are available for 35 cents a copy while the supply lasts.

October 1968

Dragstab: A finless rocket  
Wallops Station; Site of NARAM-10  
Model Rocket Altitude Calculations  
Apex J: A high altitude rocket  
Egglofter II; Lofts eggs  
Fundamentals of Dynamic Stability  
Part I  
Bomarc B: Scale

November 1968

Project Apollo  
Modifying the Camroc  
Calculating Drag Coefficients  
Model Rocket Recovery by Extensible  
Flexwing  
Versitex: Payloader rocket  
Fundamentals of Dynamic Stability  
Part II  
Japanese MT-135: Scale  
**MODEL ROCKETRY**  
BOX 214  
BOSTON, MASSACHUSETTS 02123

# DON'T MISS OUT

DON'T MISS OUT on any issues of the new **Model Rocketry** magazine – the only magazine for model rocketeers. Keep in touch with the rapidly expanding hobby-science of model rocketry. Read the latest news on NAR activities – local, regional, and national meets – construction plans – scale info – new materials and methods – math for rocket design – section news – special features – and more!\*\*\*\*\* **SUBSCRIBE TODAY!**

**Model Rocketry**  
Box 214  
Boston, Mass, 02123

Special Club Rate with 10 or more subscriptions – \$2.75.  
Have your section subscribe!

Please send me (check one):  The next 6 issues \$2.00  
 The next 12 issues \$3.50

Name \_\_\_\_\_

Street \_\_\_\_\_

City \_\_\_\_\_

State \_\_\_\_\_

Zip Code \_\_\_\_\_

# MODEL ROCKETRY

# Fundamentals of Dynamic Stability

Gordon K. Mandell

By now those who have familiarized themselves with the information presented in the preceding installments of this series should be in a position to calculate the angular motions of a model rocket subjected to disturbing moments in flight, whether or not it is spinning about its centerline, given the values of those quantities which we identified as being important in determining the nature of the dynamic response. The "set of parameters", as the required information is called, is repeated here for reference. It consists of:

- $C_1$ , the corrective moment coefficient;
- $C_2$ , the damping moment coefficient;
- $I_L$ , the longitudinal moment of inertia;
- $I_R$ , the radial moment of inertia; and
- $\dot{\omega}_Z$ , the roll rate.

Last month we presented a number of analytical techniques whereby these quantities can be calculated with a good degree of accuracy under most conditions encountered in practice. We remarked, however, that the analytical techniques are based on some simplifying approximations which, while permitting valuable information to be obtained, are not valid for all model rockets or over the entire operating range of flight conditions encountered by some models. In particular, the behavior during the critical instant following liftoff cannot always be accurately determined by the analytical approach.

Accordingly, it is usually necessary to have recourse to experiments, both to check the accuracy of the analytical determinations and to determine the the limits of

their validity. This month's discussion will deal with experiments of this nature which can be performed with a small wind tunnel and associated measuring instruments. Next month we shall conclude the series on dynamics with a presentation of design philosophy based on our findings, including the values we should like the dynamic parameters to have and the values we may reasonably expect to achieve.

---

## PART IV MEASURING THE DYNAMIC PARAMETERS

In this section we are going to describe a number of experiments whose results can be used to determine the dynamic parameters of a model rocket. These experiments require a small wind tunnel and a number of measuring instruments whose construction will be described later on. The wind tunnel in which the tests are performed should have a test section at least twelve by twelve inches in cross section and be capable of producing an airspeed of at least 50 feet per second. It would also be preferable if the airspeed were continuously variable, since this makes some of the experiments more convenient, but this feature is not essential. We do not explicitly describe the construction of a wind tunnel here, since the variety of types is considerable. Building such a

device is a major project in itself. Most modelers would rather have recourse to a facility that already exists, such as those owned by some universities, NAR sections, and model rocket manufacturers. Those who would like to build their own tunnels, however, can find information on the subject in a number of references. A simple and inexpensive design is described in Estes technical report No. TR-5, "Building a Wind Tunnel", which is obtainable for 25 cents from Estes Industries at Box 227, Penrose, Colorado 81240. Full-scale professional designs are described in *Wind Tunnel Testing*, by Alan Pope (Second Edition, John Wiley and Sons, Inc., New York, 1954). Perusal of this book should give you a good idea of the variety of wind tunnel types available and the nature of the design process involved in their planning.

### Experiment 1: Determining the Corrective Moment Coefficient

This experiment determines the value of the corrective moment coefficient by measuring the static angular deflection of a rocket produced by a known pitching moment. It requires a moment balance and test rocket as shown in Figure 1. The instrument is basically a single-degree-of-freedom gimbal consisting of a pulley wheel attached to a steel shaft which runs through ball bearings to terminate in a plug fitting. The test rocket is made in two halves, such that the forward half can be snugly slid onto one end of the plug fitting, the after half onto the other. Because of the restriction only a *design* can be tested, not an actual



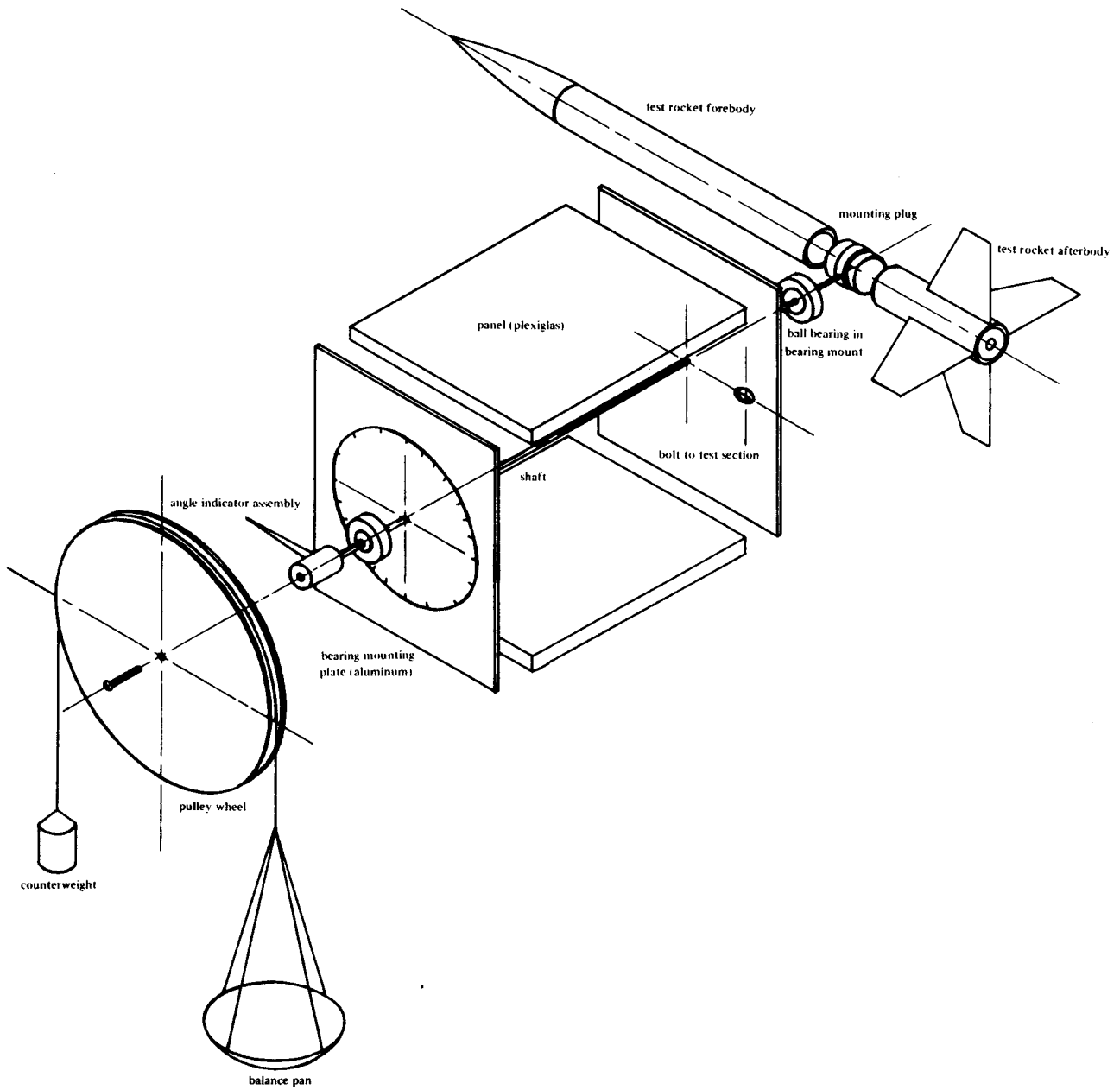

Figure 1. The moment balance and test rocket design used in performing Experiments 1 and 2. The pulley wheel is removed when Experiment 2 is being done.

GM

rocket which is to be flown. The advantage of the arrangement is that it produces a minimal disturbance in the airflow.

That portion of the shaft which lies between the case in which the bearings are mounted and the plug fitting extends through a hole in the wall of the wind tunnel test section and into the airstream, such that the plug is located approximately in the center of the test section. The case is bolted to the side of the test section opposite the main viewing area in order to hold the instrument in place.

An angle-measuring device of some kind is also needed. A simple pointer-and-protractor arrangement which is adequate for this experiment is illustrated in Figure 1. In the experiments described later, though, where the rocket is set to oscillating, it will become desirable to *record* the variation of angular deflection with time. While this can be done with motion pictures and in various other ways using the protractor system, it is usually preferred to substitute some electrical device for measuring the angle and to feed its output into a chart recorder, which then draws a graph of deflection versus time.

In order to generate the moment which will deflect the rocket it is necessary to apply a force tangential to the pulley wheel at its outer radius. This is done by suspending a balance pan from a thin cord which has been wrapped around the pulley and adding known weights to the pan. The balance pan must be suitably counter-weighted so that there is no moment applied when no weights are in the pan.

To perform the experiment, prepare the test rocket by adjusting or adding weights as necessary so that, when assembled on the plug with an engine installed, it balances when the airstream is off and there is no weight in the pan. This will mean that the shaft centerline passes through the model's center of mass, so that free-flight conditions will be accurately simulated.

Now turn on the airstream and adjust it to some fixed value, say 50 feet per second. This value must not be altered during the experiment. The model should now be facing directly into the oncoming wind, which in a good wind tunnel will coincide with the centerline of the test section. If the model fails to face into the wind it is unstable and should be redesigned. Assuming the model is facing the airstream properly, the next step is to check the angle indicator and adjust if necessary so that it reads zero.

Once this is done, you can begin to add weight to the pan. Find a unit of weight which produces a small deflection, say around  $2^\circ$  or so, but which is an even quantity (that is, a single laboratory balance weight or simple combination of weights). This will greatly increase the convenience of taking data. Record the weight used and the exact deflection it produced. Then add

another weight of this same amount and record the new deflection. Read the deflection from zero, not from the old position, and be sure to wait for all movement to subside before taking a reading. Continue in this manner, recording the deflection from zero and the total weight on the pan associated with this deflection, until a deflection of about  $20^\circ$  is reached.

The experiment is now complete and you may begin to reduce the data. The first thing to do is to transform the units in which the data is expressed. Angular deflection must be expressed in radians and the moments associated with them must be given in dyne-centimeters. Deflections in degrees are changed to deflections in radians by dividing by 57.3. A moment in dyne-centimeters is computed by multiplying the mass (in grams) placed on the pan by 980, and multiplying the result thus obtained by the radius of the pulley wheel in centimeters. This process is illustrated in Figure 2, and when completed for all readings should provide a table listing each deflection in

radians next to the moment required to produce that deflection in dyne-centimeters.

Next, these data points are plotted on a graph in cartesian coordinates whose horizontal axis represents deflection in radians and whose vertical axis represents moment in dyne-centimeters. Such a plot is made by locating each point described by a coordinate pair (a deflection and its associated moment) on the graph and marking it with a small x or dot, then drawing a smooth curve which, as nearly as possible, connects all the points. Since experimental data normally contains some "scatter", it is more important that the curve be smooth than that it connect all the points. The resulting graph is a representation of corrective moment as a function of angle of attack. In order to compute  $C_1$  from this graph, place a straightedge on it such that its edge is tangent to the curve at the intersection of the coordinate axes (the origin) and draw a line using the straight edge as a guide. You have now performed a "linearization about

$$\text{DEFLECTION ANGLE (RADIAN)} = \frac{\alpha}{57.3}$$

$$\text{MOMENT (DYNE-CM)} = M \times 980 \times R$$

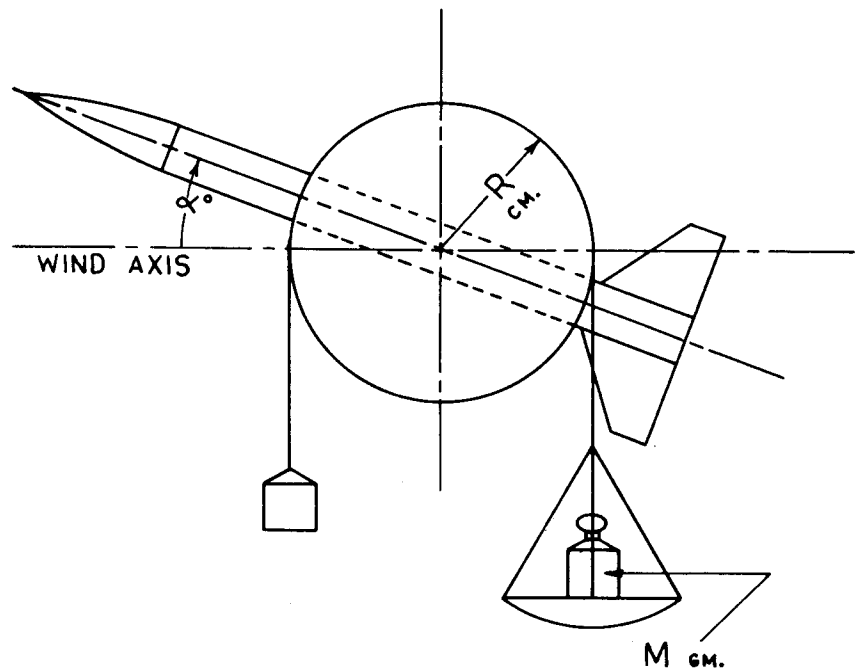

Figure 2. Computing angular deflection in radians and moment in dyne-centimeters.

MOMENT (10<sup>5</sup> DYNE - CM)

DEFLECTION ANGLE (RADIAN)

(A)

0.0	.0000
0.625	.0125
1.250	.0240
1.875	.0390
2.500	.0490
3.125	.0625
3.750	.0770
4.375	.0875
5.000	.1000
5.625	.1135
6.250	.1340
6.875	.1610
7.500	.1852
8.125	.2315

(B)

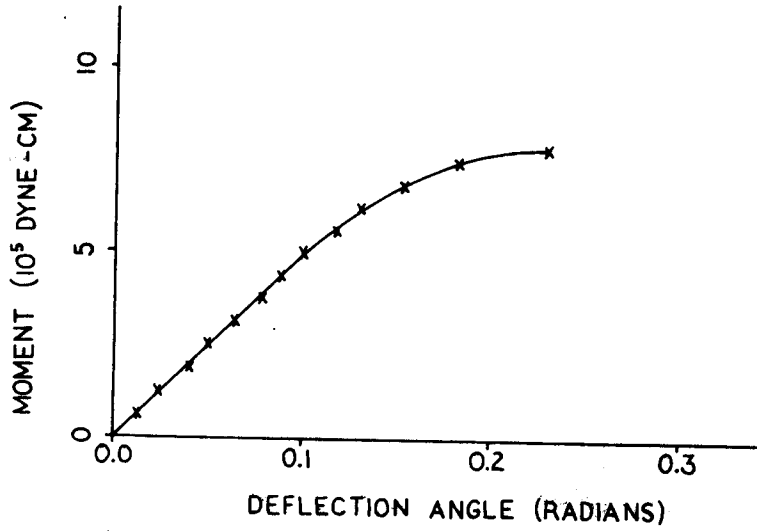

(C)

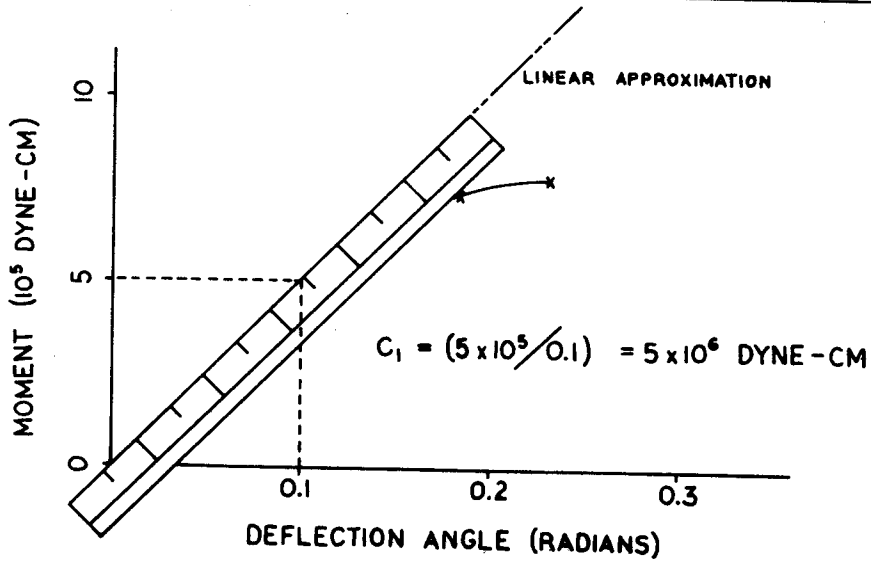

GM

Figure 3. Determining corrective moment coefficient from the results of Experiment 1. A: Data reduced to tabular form. B: Plotting data points and drawing the graph. C: Performing the linearization and computing  $C_1$ .

zero" of the corrective moment as described in Part I (October, 1968 Model Rocketry). The corrective moment coefficient is just the slope of the straight line, which may be readily found by locating any point on the straight line and dividing its moment coordinate by its deflection coordinate. The result is  $C_1$  given in dyne-centimeters/radian, but is expressed as dyne-centimeters, since radians are physically dimensionless. The reduction of data for a hypothetical rocket is shown in Figure 3.

You may want to repeat the experiment at different airspeeds to determine the variation of  $C_1$  under these conditions. If you do this, you should find that  $C_1$  is proportional to the square of the airspeed.

### Experiment 2: Determining the Damping Moment Coefficient and Longitudinal Moment of Inertia

The dynamic parameters  $C_2$  and  $I_L$  may be determined using the same moment balance as in the first experiment, with the exception that the pulley wheel and its associated pan and counterweight system must be removed. This is done in order to reduce the moment of inertia contributed by the rotating parts of the balance system. Unless this modification is carried out the experiment will yield a value of  $I_L$  that is much too high.

Prepare the experiment by balancing the test rocket so that the shaft passes through its center of mass as in Experiment 1. Again, turn on the wind tunnel and set the velocity to the desired value, which must be constant during the test, and make sure the angle indicator is reading zero.

To perform the experiment, first deflect the rocket to some moderate angle, say  $10^\circ$ , and hold it steady in that position. You may wish to have an assistant do this by turning the shaft with his hand in order to increase the convenience of the subsequent observations, or you may devise various automatic systems to do the job. One simple technique for obtaining the initial deflection would be to wrap a length of strong thread around the end of the shaft from which the pulley has been removed and tie a weight to the thread. In any case, record the value of the initial deflection you have produced. We shall refer to this angle as  $\alpha_0$ .

Now release the rocket and allow it to rotate into the wind of its own accord. If you have used the thread-and-weight system for producing the initial deflection, you can do this by carefully snipping the thread with a pair of scissors. The rocket should swing toward zero deflection and overshoot it, reaching a maximum angle which we shall call  $\alpha_1$  on the opposite side of zero from that on which it was released, and subsequently oscillating with smaller and smaller amplitude about zero until it is facing

steadily into the oncoming wind. Our convention for representing  $\alpha_0$  and  $\alpha_1$ , whose signs are both taken as positive, is shown in Figure 4. The maximum overshoot angle  $\alpha_1$  will be reached at a time defined as  $t_{max}$  after the rocket is released. You must carefully record both the maximum overshoot angle and the time at which it occurs; in the case of angle indicators consisting only of a simple pointer-and-protractor,  $\alpha_1$  must be recorded by eye (or photographic means) and  $t_{max}$  by a stopwatch. An electrical system for measuring and recording the deflections has a big advantage here, since it takes the guesswork out of the observations (provided it is working properly!).

If, upon being released, the model does not oscillate but instead slowly faces into the airstream from the position of initial deflection, it is overdamped. This may occur if the air speed you have chosen for the test is too low, say less than 30 feet per second. If you do this you are simulating a portion of the rocket's flight which is not of interest: it is either still travelling up the launch rail or approaching the apex of its trajectory. Most model rockets leave the end of the launcher at airspeeds of 30 feet per second or greater, continuing to accelerate in free flight until velocities of several hundred feet per second are reached. If your model behaves in an overdamped fashion at speeds in excess of 30 feet per second there is some danger that it will have unpredictable flight path during the instant following launch. The "overdamped launch," we suspect, has been responsible for the premature demise of a fair number

of model rockets. If, therefore, you cannot obtain oscillatory behavior in the test model at an airspeed of 30 feet per second or above, the chances are that the rocket needs to be redesigned. Additional nose weight will usually take care of this problem, but since this moves the center of mass forward it will require the building of a new test model which is divided in two further toward the nose.

Assuming that the rocket has behaved in a properly oscillatory fashion and that  $\alpha_0$ ,  $\alpha_1$ , and  $t_{max}$  have all been duly recorded, the values of  $C_2$  and  $I_L$  may be computed as follows:

$$\text{Step I: } D = \frac{\ln\left(\frac{\alpha_0}{\alpha_1}\right)}{\tau_{MAX}}$$

where  $D = \frac{C_2}{2I_L}$  and " $\ln\left(\frac{\alpha_0}{\alpha_1}\right)$ " refers to the natural logarithm of the quantity  $\frac{\alpha_0}{\alpha_1}$ . As we remarked in Part I of this series, the natural logarithm of a number may be found by looking it up in a table of natural, or Napierian, logarithms. The 'LL' and 'D' scales of a log-log scale slide rule can also be used for this determination. Be careful to express  $t_{max}$  in seconds when doing this calculation.

$$\text{Step II: } I_L = \frac{C_1}{D^2 + \left(\frac{\pi}{\tau_{MAX}}\right)^2}$$

where  $C_1$  is known from Experiment 1 and  $D$  is known from Step I.

$$\text{Step III: } C_2 = 2 I_L D$$

where  $I_L$  and  $D$  are the values determined in the first two steps above.

This method will give  $I_L$  in

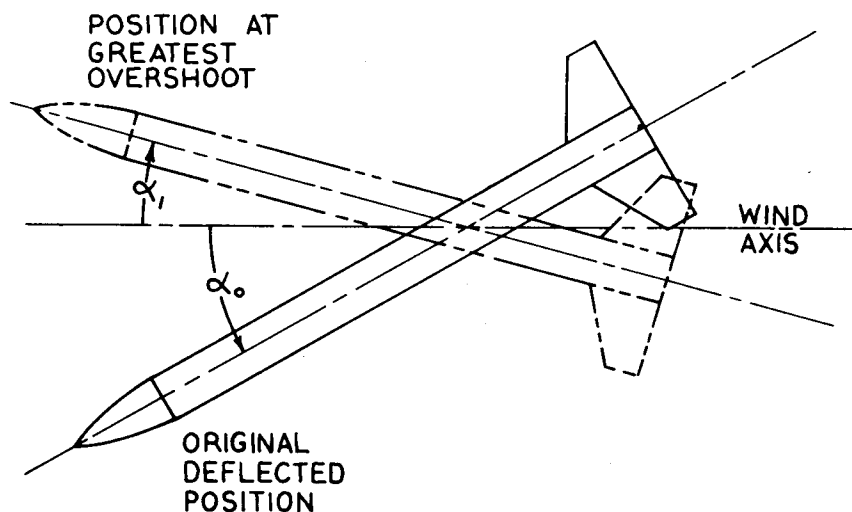

Figure 4. Definitions of  $\alpha_0$  and  $\alpha_1$  when doing Experiment 2.

dyne-centimeter-seconds<sup>2</sup> if  $C_1$  is expressed as directed in Experiment 1.

As in Experiment 1, you may wish to perform this test at various airspeeds. At airspeed above a certain minimum point, which varies from rocket to rocket, you should find that  $C_2$  increases linearly with airspeed, so that the *damping ratio*  $\zeta$  defined by

$$\zeta = \frac{C_2}{2\sqrt{C_1 I_L}}$$

remains essentially constant.  $I_L$ , of course, is a mass property of the rocket and does not vary with airspeed.

### Experiment 3: Determining the Radial Moment of Inertia

This experiment allows the observation of the resonance characteristics of a rocket which is rolling, or spinning about its centerline. Because the model must be driven in roll by an electric motor, and because it must be free to yaw as well as pitch, the gimbal system required to operate this experiment is more complicated than that used in the previous investigations. The design of the apparatus and test rocket is shown in Figure 5.

Unlike the version used in Experiments 1 and 2, this instrument must have the capability to drive the electric motor used to control the roll rate of the rocket. For this reason one of the pin-pivots used in the yaw gimbal is maintained at a positive voltage; the other at ground. The positive pivot wire (which can be made of .045" music wire) is given the shape illustrated and inserted into a length of brass tubing which serves as that portion of the balance shaft passing through the bearing nearest to the motor. This pivot wire is tacked to the inside of the tube with a bit of solder. The tube itself is maintained electrically positive during a test run by applying a positive voltage to a "slip ring", a drilled-out brass rod which slides freely over the tubular shaft and to which a wire from the battery or other power supply is attached. The bearing itself should not be used to carry electricity, as this requires it to run "dry" (i.e., without any oil) and may also cause it to be damaged by sparking. From the tubular shaft the current is conducted through the positive pivot-wire to the tip of the positive pin, and thence to the socket fitting which has been epoxied to the motor case. The positive wire from the motor terminals, in turn, has been soldered to this fitting.

The negative motor wire is joined to the opposite socket fitting, which in turn is in electrical contact with the negative pin-pivot. The negative pivot wire is also inserted into the forward section of the tubular balance shaft, but is *insulated* being nowhere allowed metal-to-metal contact with it. The insulation is best accomplished with heat-shrinkable "spaghetti tubing", available in most electronics supply houses. The

negative pivot wire then passes through the hollow core of a plexiglas or bakelite insulating coupling into the other portion of the tubular shaft. The insulation on the negative pivot wire ceases after the wire passes through the coupling, and the bare wire is soldered to the inside of the tube which passes through the bearing farthest from the motor. Another slip ring carries the current from the rear shaft section to the power supply to complete the circuit. The forward bearing mounting plate is insulated from the rear plate, as the top and bottom panels of the case are made of plexiglas.

The electric motor itself must be carefully selected. It must be of nearly the same diameter as the test rocket body tube, so as not to disturb the airflow, and must run smoothly at low speeds. In addition, it must have a double-ended shaft so that mounting plugs can be fastened to either end. The Distler "Aristo-Craft" motor has been found to answer these requirements very well. The 4.5-volt DC motor, made in Belgium, is available from many hobby shops and mail order houses. It is an inch in diameter at the ends and 0.94 inches in the center portion of the body, being thus the right size for test rockets made with Estes BT-50 or Centuri Series No. 10 body tubes. The center portion of the motor body is built up to one inch diameter with model aircraft silk and a suitable resin compound such as Hobbypoxy. The pivot socket fittings, of brass strip drilled to fit the pivot wire, are soldered to the motor wires (which must be shortened to keep the arrangement tidy) and then epoxied to the silk wrapping in diametrically opposite positions, being thus insulated from the motor case.

In the remainder of its features, this three-degree-of-freedom balance is substantially the same as the single-degree-of-freedom system used in Experiments 1 and 2. In fact, with the roll motor off, there is no reason why Experiments 1 and 2 could not be performed with this more complicated mechanism, provided that arrangements for mounting the pulley wheel are made. However, you may want to start off with the simpler, single-degree-of-freedom balance and become proficient at the experiments which can be done with it before attempting the more complex arrangement.

The test rocket used on this instrument must also be slightly different in design. Of course, the body tubes must be shortened to allow for the length of the electric motor (about 2.5" for the Distler motor), but in addition these models feature a "disturbance vane". This is just a deflected elevon glued to the after face of the rocket motor casing. When the casing is inserted into the after end of the body tube, the vane applies a disturbing moment to a test model held in a moving airstream. It is this moment which will induce resonance when the rocket is spinning at the proper rate.

To prepare the experiment, set up and balance the rocket on the mounting plugs as before, with the airstream and roll motor both off. Then remove the casing with the disturbance vane mounted on it and replace it with an ordinary casing of the same weight. Now turn on the airstream, leaving the roll motor off. The rocket should face into the oncoming airstream, whereupon you should adjust the angle indicating mechanism to read zero if it is not doing so.

Turn off the airstream and replace the disturbance vane. Turn it on again and adjust it to the desired value of airspeed, which should not change during the run. The disturbance vane will cause the rocket to acquire a small, constant angle of attack. Record it as accurately as possible, call it  $A_0$ . Next, using a rheostat or other control, gradually increase the voltage to the motor until the rocket just starts to spin. Wait for its roll rate to become steady. The rocket's longitudinal axis will now be describing a cone about the original, undeflected position. The cone's half-angle is the maximum indicated angular deflection above or below zero. Increase the voltage to the roll motor repeatedly in small steps, each time waiting for the rocket to come up to a steady spin rate. You should notice that the cone half-angle increases with spin rate up to a certain value, and then decreases again once this value is surpassed. Carefully locate the spin rate at which the deflection is a maximum and measure and record both the deflection and spin rate. In order to do this, you may need an instrument called a Strobotach, particularly if the roll rate is rapid. The Strobotach is a flashing light, the frequency of whose flashes is adjustable. When the frequency of the Strobotach, in flashes per second, is equal to the rate, in revolutions per second, the rocket will appear "frozen" in position when viewed under the Strobotach's light in a darkened room. The angular frequency of the motion, in radians per second, is then computed by multiplying the Strobotach frequency by  $2\pi$ . The maximum half-angle is called  $A_{res}$ , while the angular frequency at which it occurs is called  $\omega_{res}$ . These parameters characterize the "resonance peak" of the rocket.

If the conical half-angle decreases uniformly as the roll rate increases from zero, the airspeed may be too low. Try increasing it to about 40 feet per second. If there is still no resonance peak, the rocket is too highly damped and should be redesigned as described in Experiment 2.

Assuming that a resonance peak was observed, the value of  $I_R$  can be computed as follows:

$$\text{Step I: } \zeta_c \sqrt{1 - \zeta_c^2} = \frac{1}{2R}$$

$$\text{where } R = \frac{A_{res}}{A_0}$$

and  $\zeta_c$  = coupled damping ratio

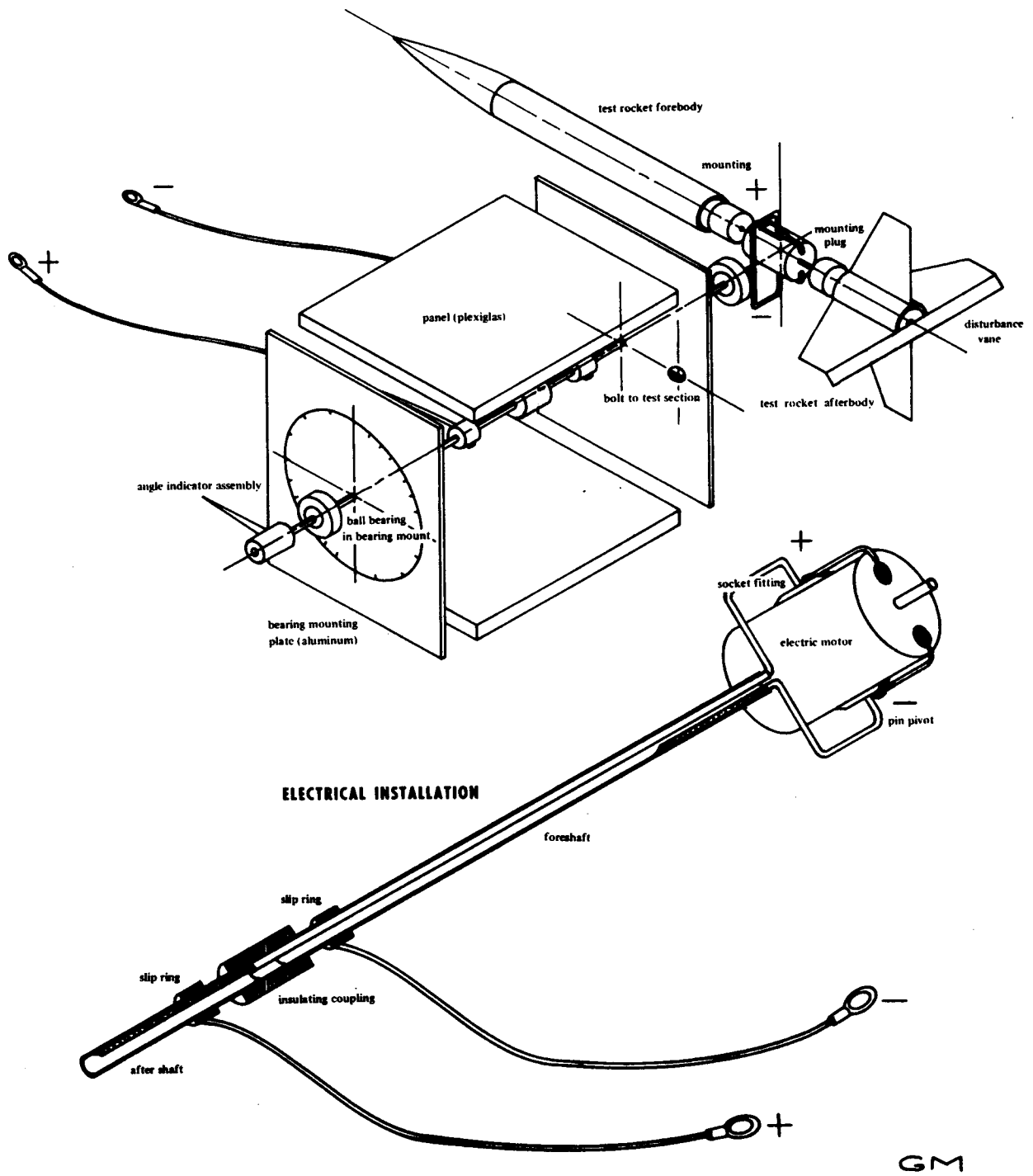

Figure 5. The moment balance and test rocket design used in performing Experiment 3.

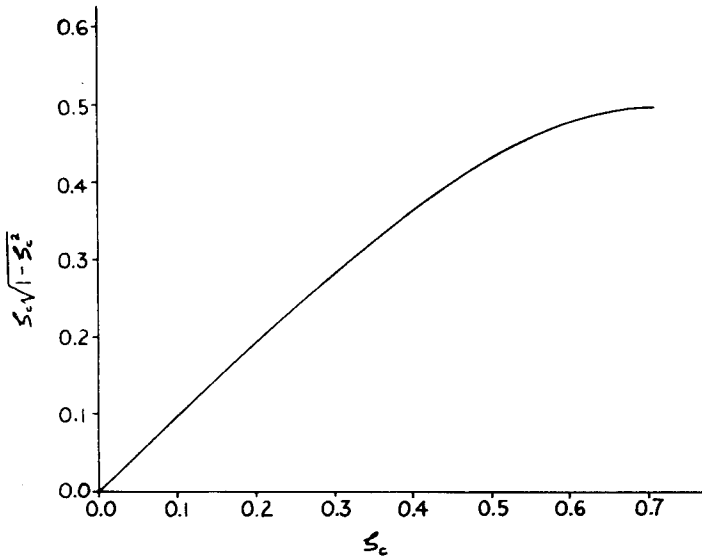

Figure 6. The value of the function  $\zeta_c \sqrt{1 - \zeta_c^2}$  over a range of coupled damping ratios extending from zero to .7071.

This relation *could* be used to determine  $\zeta_c$  analytically, but this is cumbersome. The most straightforward method is to draw a graph of  $\zeta_c \sqrt{1 - \zeta_c^2}$  as a function of  $\zeta_c$ . This has been done in Figure 6. In order to find  $\zeta_c$  after determining  $\zeta_c \sqrt{1 - \zeta_c^2}$ , locate the point on the curve whose vertical coordinate has the known value of  $\zeta_c \sqrt{1 - \zeta_c^2}$ . The horizontal coordinate of this point is  $\zeta_c$ . Note that the graph has not been continued beyond  $\zeta_c = .7071$ , since there is no resonance for greater values.

$$\text{Step II: } \omega_{mc} = \frac{\omega_{cres}}{\sqrt{1 - 2\zeta_c^2}}$$

where  $\omega_{mc}$  = coupled natural frequency and  $\zeta_c$  is known from Step I.

$$\text{Step III: } I_L + I_R = \frac{C_1}{\omega_{mc}^2}$$

where  $C_1$  is known from Experiment 1 and  $\omega_{mc}$  from Step II above.

$$\text{Step IV: } I_R = (I_L + I_R) - I_L$$

where  $I_L$  is known from Experiment 2.

Step V: If desired,  $C_2$  can be determined from the relation

$$C_2 = 2\zeta_c \sqrt{C_1(I_L + I_R)}$$

It is probably a good idea to make this second determination of  $C_2$ , since the rolling of the rocket might conceivably affect the damping moment coefficient. We remark that, if all the dynamic parameters of a single design are to be determined, care must be taken to insure that the value of  $I_L$  as measured in Experiment 2 accurately describes the test rocket and balance assembly of Experiment 3. If there is even a small difference, the measured value of  $I_R$  could turn out to be *negative*, which is certainly incorrect! Or it might be computed as two or three times its true value. It is good practice to repeat Experiment 2 with the setup for Experiment 3, just to see how closely the experimental values of  $C_2$  and  $I_L$  match. The mass properties of the test model may have to be adjusted with weights to obtain a good agreement. Alternatively, as we said before, you may want to fit the balance of Figure 5 to do all three experiments, although unwanted yawing motions in the first two experiments may make this somewhat inconvenient. In your determination you may have noticed that the value of  $R$  you observed was quite large. If it was more than 5 or so the design would be in serious trouble if it would develop a roll rate in free flight. Its damping moment coefficient is in this case too low and some attempt to increase it is in order. In next month's *Model Rocketry* we shall discuss situations such as this in attempting to define "good" values of the dynamic parameters and ways to obtain them.

today's fun  
tomorrow's career

SPACE FUTURE OR NOT . . . LEARN WHILE YOU BUILD AND FLY

ESTES MODEL **ROCKETS**

**BLAST OFF INTO A NEW WORLD OF AERO-SPACE ADVENTURE**

Join the countdown to the space age. Be an Estes model rocketeer. Over 35 exciting kits ready for you to build and fly . . . contest models, starter kits, detailed scale models of the real thing. Parachute recovery and flights up to 2500 feet. Try an Estes "big shot" today!

**Take your first step now — Order a starter kit**

Count down . . . blast off. Space career or not, you'll find this new aero-space hobby offers hours of challenge and adventure.

**STARTER SPECIAL**

INCLUDES ALPHA KIT, 2 engines, design manual, instructions. # DSK-20 . . . \$2.00  
SAME AS ABOVE, plus launcher. # DSK-65 . . . \$6.50  
New illustrated catalog (free with order) . . . 25c



Big 96 page color catalog . . . 25c (Free with order)

**ESTES INDUSTRIES**  
Dept. 31, Penrose, Colorado 81240

# Reader Design Page

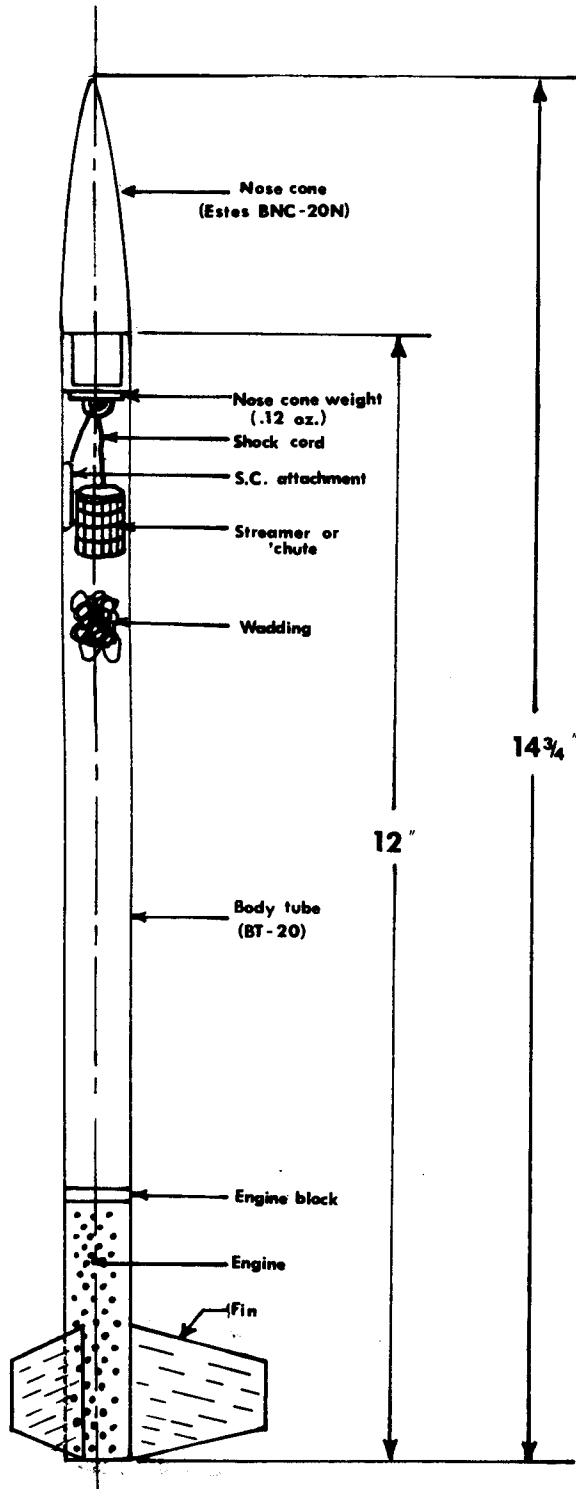

This month's reader design, a single stage sport rocket, was submitted by Kevin Brown of Wenona, Ill.

Challenger I grew out of an attempt to design an aesthetically pleasing model incorporating the general proportions of a sounding rocket. The result is a deceptively simple, yet good-looking model with excellent performance characteristics. The requirement of sounding rocket proportions dictated that the fins be relatively small. In order to maintain stability with these small fins, a nose weight is employed to shift the center of gravity forward. This weight *must* be included if the rocket is to be stable.

In keeping with the sounding rocket format, the original model was painted gloss white, with the nose cone and one fin dark blue. However, the designer suggests that your model be painted bright orange or red for ease of tracking. It may be flown with any standard engine, but best performance will be obtained with a B6-6 or C6-7.

*Each month Model Rocketry will award a \$5.00 prize for the best original rocket design submitted by a reader during the preceding month. To be eligible for this prize, entries must be suitable for offset reproduction. They should be carefully drawn in black ink on a single sheet of 8 1/2 by 11 paper. Sufficient information should be contained in the drawing so that the rocket can be constructed without any additional information.*

Submit entries to:  
 Rocket Design  
 Model Rocketry  
 Box 214  
 Boston, Mass., 02123

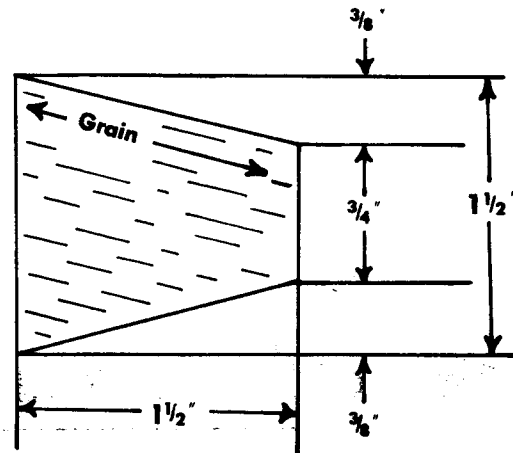

**Full-size Fin Pattern  
 (3 required)**



## CLUB NOTES

"Model rocketry is alive and well in California!" Thus opens the first issue of *The Tracker*, newsletter of the Southland Section of the NAR. It reports the results of that club's first NAR sanctioned meet. Eleven members competed at the group's Mile Square launch site in Fountain Valley, California on the morning of November 16. Winners were: Philip Kemp in Class I Parachute Duration with 5 minutes 18.5 seconds, and Vince Jahn Jr. in Scale with 891 points for his IQSY Tomahawk No. 4. The only successful boost-glider flight went out of sight so there was no winner in that event.

Nine members of the Southland Section attended the 1968 Space Fair at the US Navy Pacific Missile Range, Point Mugu, California. These rocketeers witnessed an air show featuring the Blue Angels demonstration team, and a Sidewinder missile firing. Members also gathered scale data from the many missiles on view.

The Apollo-NASA section of the NAR reports that Houston was one of the sites considered for NARAM 11—the 11th annual National Rocket Meet of the NAR. Though Houston was not selected to host NARAM 11, the Apollo-NASA section hopes to have Houston designated the site of NARAM 12.

Results of the October 18, 19, 20 meet between the NARHAMS and MARS sections of the NAR were reported in the December issue of *Zog* 43. Heavy rain on Saturday forced five events to be flown on Sunday, the last day of the meet. The MARS section beat the NARHAMS with 1035 points to 669 points. Individual leaders were M. Mercer with 162 points, B. Blackstone with 78 points, and D. O'Steen with 72 points.

The Model Rocket Space Clubs have added another division to their ranks. The Sun Valley Rocket Club, now Division 2-B of M.R.S.C., is located in Utica, Michigan.

This club, which publishes its own newsletter, has 16 members.

The MIT Section of the NAR has announced that it will host a Northeast Regional Research and Development Competition in conjunction with its own National Convention. The convention, which will be held on the MIT campus, will run from April 12 through 14, 1969. For further information and literature, contact George Caporaso, Bos 110, MIT Branch Post Office, Cambridge, Mass. 02139.

The Saucon Valley Rocketry Club of Hellertown, Pennsylvania is looking for a senior NAR member to help them on either Monday afternoons or Saturdays. The club meets in Miss Fritchman's room of the Saucon Valley High School in Hellertown. Anyone available on Mondays should contact Miss Fritchman through the school. Anyone available on Saturdays should contact Douglas List, 38 W. University Ave., Bethlehem, Penn., 18015.

Send your club or section newsletters, contest announcements and results, and other news for this column to:

Club News Editor  
Model Rocketry Magazine  
P. O. Box 214  
Boston, Mass., 02123

## HOBBY SHOPS

Your local hobby shops can supply balsa wood, decals, tools, paint, magazines, and many other model rocket supplies.

Mention Model Rocketry to your local hobby dealer.

### MODEL ROCKET SUPPLIES

**TOTOWA HOBBY SHOP**  
Harold M. Zafeman  
388 Union Ave.  
Paterson 2, N. J.  
279-0106

**We Sell Estes Rocket Kits  
and Supplies**  
Mail Orders Filled  
**PAVONE'S SHOE HOSPITAL**  
20 Margret Street  
Platsburg, New York, 12901

Buffalo and Western New York's  
No. 1 Rocket Center  
*Estes - Centuri - Kel Rockets*  
**Howard Ruth Hobby Center**  
1466 Genesee St.  
Buffalo, N. Y.  
*Join Our Rocket Club!*

Western New York Headquarters for Rockets and Supplies is  
**GRELL'S FAMILY HOBBY SHOP**

5225 Main St.  
Williamsville, New York

Open 7 days a week

Phone 632-3165

### Centuri - Estes - MRI

Send Self-addressed stamped envelope for free listing of all the latest in hobby kits at special prices.

**Bristol Hobby Center**  
43 Middle St.  
Bristol, Conn., 06010

TUCSON, ARIZONA....

"in Tucson" it's  
**DON'S HOBBY**  
for model Rocketry

2954 N. Tucson Blvd. 327-0565

**Support your local  
Hobby Shop**

Only \$1.00

This full color reproduction, 8½ by 22 inches in size, and suitable for framing can be yours for only \$1.00 (or 6 for \$5.00), plus 25 cents for postage from:

**ASTRO PHOTOS**  
2278 West 6th Street  
Brooklyn, New York

Limited Supply!

Order Your Copy Now!

**ASTRO PHOTOS**  
2278 West 6th Street  
Brooklyn, New York

8-1/2 X 22inch

Full Color Photo

Taken by

**APOLLO 8 Astronauts**

This spectacular view of the rising earth greeted the Apollo 8 astronauts as they came from behind the moon after the lunar orbit insertion burn. The surface features visible on the moon are near the eastern limb of the moon as viewed from the earth. The lunar horizon is approximately 780 kilometers from the spacecraft. The width of the area photographed is about 175 kilometers at the horizon. On the earth, 240,000 miles away, the sunset terminator bisects Africa.